

Problems of Biogeochemistry II

On the Fundamental Material-Energetic Distinction Between Living and Nonliving Natural Bodies of The Biosphere

by Vladimir Ivanovich Vernadsky

The first complete English translation of a 1938 article by the innovative Russian biogeochemist, who saw the human mind as the highest development of natural processes.

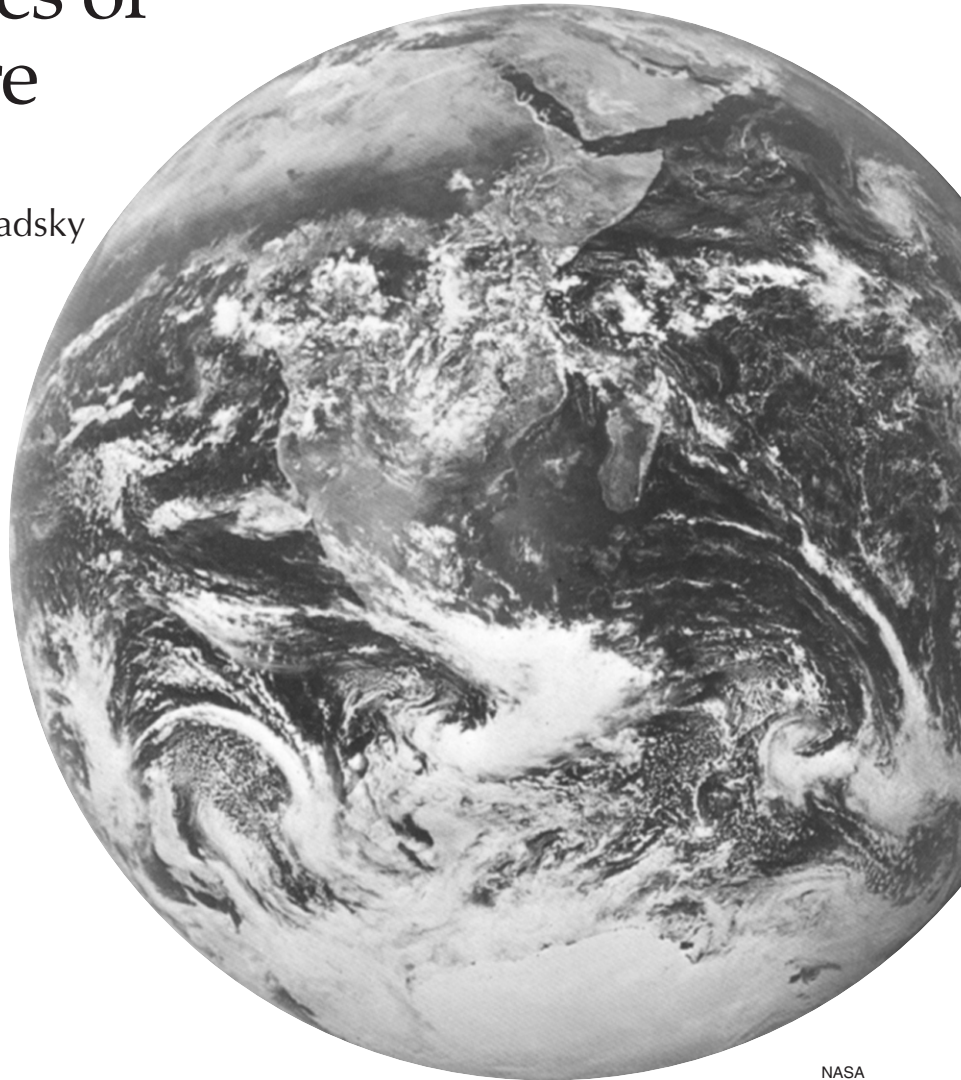



Vladimir Ivanovich Vernadsky (1863-1945), who developed the concept of the biosphere and how man's creativity has changed it into the noosphere.

EDITOR'S NOTE

An introduction to this translation appears in the editorial section, page 2. The article was translated from the Russian by Jonathan Tennenbaum and Rachel Douglas. An abridged translation into English, by Vernadsky's son, George, appeared in the June 1944 Transactions of the Connecticut Academy of Arts and Sciences.

Two systems for the transliteration of Russian into English are used here: The bibliographical references in the notes are given in the Library of Congress system. In the text, the transliteration is modified to better approximate Russian pronunciation.

Translator's notes are included in brackets. The numbered footnotes are V.I. Vernadsky's. His parenthetical references to "Sections" refer to the numbered sections of this article.

Foreword

Three years have passed before the author has been able to return to *Problems of Biogeochemistry*.¹ Having been at work recently on the book, *The Basic Concepts of Biogeochemistry in Connection with the Scientific Comprehension of Nature*, the author considers it useful—without waiting for its completion, which will necessarily be delayed—to split off and develop separately in *Problems of Biogeochemistry*, certain specific questions, touched upon in the book, to which he finds it necessary to draw attention right away. One such problem, empirically established by the author in this second issue of *Problems of Biogeochemistry*, is the fundamental material-energetic distinction of living matter in the biosphere, from all other of the biosphere's natural objects and occurrences; a distinction that admits of no exception.

The author has approached this question, starting from the study of life as the totality of all living organisms on the planet—that is, the planet's living matter—, taking into account the special structure of the domain, inhabited by living matter—the biosphere, the sole area of the planet, which is lawfully connected with the expanses of cosmic space. It seems to the author, that before now no one has approached the phenomena of life from this side, yet this new approach leads to major consequences, which can be verified by experience and observation. The author considers, that the table published below includes no hypotheses or theories, but rather constitutes an exact presentation of scientific facts and empirical generalizations flowing from those facts. The table does not depart from the framework of science into the domain of philosophical notions, but at the same time it sharply and decisively reveals the significance of life—living matter—in the biosphere, as a planetary phenomenon.

In connection with the general questions raised here, the author, in a third issue now in preparation for publication, poses the still more general question of "the states of physical space," which concerns not only biogeochemistry, but all investigations of Nature, and which is inseparably connected with the problems of biogeochemistry. The author hopes to publish it in the near future. The topics of these two publications are closely connected.

—Moscow, September 1938

I. Basic Concepts

Living matter, the biosphere as an envelope of the planet. Its new geological state—the noosphere. Natural bodies and the natural phenomena of the biosphere—inert, living, and bio-inert. Their system—the scientific apparatus. Left-handedness and right-handedness in living matter as a manifestation of the state of the space it occupies. The free energy of the biosphere as a manifestation of the biogeochemical energy of the living matter in the biosphere.

1 In my biogeochemical work, which I have pursued systematically and without interruption since the beginning of 1916, I have recently framed conclusions, which point to the deep, unbridgeable distinction—energetic-material in character—between the phenomena of life, and all other processes, occurring in the biosphere; a distinction which, on the one hand, can be expressed with quantitative precision, but which, on the other, calls for new mathematical work in the domain of geometry. Revealed before us, is a new area of the study of life phenomena, which uncovers new facets of the phenomena of life and new possibilities for scientific work. I therefore consider it useful to call attention to these conceptions, rather than waiting for the completion of my reworking of biogeochemistry.

2 The foundations of biogeochemistry are formed from a

few basic conceptions, which *do not contain any hypotheses*, but are precise and clear scientific concepts—scientific empirical generalizations of the naturalist's experience and observation. Above all, the very concept of *the living matter of the biosphere* represents such an empirical scientific generalization—one that is as indisputable as a correctly, scientifically established fact. *The living matter of the biosphere is the aggregate of all its living organisms.*

In the following I shall use, instead of the concept "life," the concept "living matter" in the indicated sense.

From the standpoint of the biosphere, the individual living organism is usually lost from view; in first place comes the aggregate of organisms—living matter. In biogeochemistry, however—in some strictly defined cases—at times it is necessary to pay attention to the discrete organism, to its individuality. It is indispensable to do this in those cases, where the activity of Man appears as a geological factor, as we see happening now, and the individual personality sometimes becomes vividly apparent and is reflected in large-scale phenomena of a planetary character. The human personality changes, accelerates, and causes geological processes of enormous significance, through its presence in the biosphere.

We are living in a brand new, bright geological epoch. Man, through his labor—and his conscious relationship to life—is transforming the envelope of the Earth—the geological region of life, the *biosphere*. Man is shifting it into a new geological state: Through his labor and his consciousness, the biosphere is in a process of transition to the *noosphere*.² Man is creating new biogeochemical processes, which never existed before. The biogeochemical history of the chemical elements—a planetary phenomenon—is drastically changing. Enormous masses of new, free metals and their alloys are being created on Earth, for example, ones which never existed here before, such as aluminum, magnesium, and calcium. Plant and animal life are being changed and disturbed in the most drastic manner. New species and races are being created. The face of the Earth is changing profoundly. The stage of the noosphere is being created. Within the Earth's biosphere, an intense blossoming is in process, the



Courtesy of the History of Geology Department, Vernadsky State Geological Museum, Russian Academy of Sciences

Vernadsky with his students, around 1905. From left, seated: V.M. Tsebrikov, E.D. Revutskaya, S.P. Popov, Vernadsky, Ya. V. Samoilov; standing: V.V. Karandeyev, N.I. Surgunov, V.V. Arshinov, N.N. Bogolyubov, G.O. Kasperovich.

further history of which will be grandiose, it seems to us.

In this geological process—which is fundamentally biogeochemical—a single individual unit of living matter, out of the totality of humanity—a great personality, whether a scientist, an inventor, or a statesman—can be of fundamental, decisive, directing importance, and can manifest himself as a *geological force*. This sort of manifestation of individuality in processes of enormous biogeochemical importance, is a new planetary phenomenon. It emerged, and began to manifest itself ever more sharply and profoundly in the course of time, *during the most recent tens of thousands of years*, on the background of billions of years of the prior history of the biosphere, when this phenomenon did not exist.

In biogeochemical processes—outside the boundaries of these phenomena—the totality of living beings—living matter, continues to play the basic role. It is characterized as the totality of all organisms, mathematically expressed as the totality of *average* living organisms. Biogeochemistry studies, above all, the manifestation of the totality, not of the average indivisible unit. In the majority of the other biological sciences, we chiefly study the average indivisible unit; and, in the sciences of medicine and animal husbandry, the indivisible unit, individuality, or the single personality has been of outstanding significance during the past millennia.

Morphologically, living matter is manifested in biogeochemistry as a species, genus, race, etc. We distinguish *homogeneous living matter—belonging to a genus, species, etc.—and heterogeneous living matter*, such as the forest, the steppe, or a biotic community in general, consisting of homogeneous forms of living matter, in certain proportions.³ The convenience of this approach to the phenomena of life lies in the fact that we do not stray, in our judgments and conceptions, into the shaky domain of hypotheses and philosophical constructs about life, such as dominate the thinking in biology. We do not depart from the domain of scientific facts and scientific empirical generalizations; we stand on their firm ground.

3 Alongside the concept of living matter, we put forward two other empirical generalizations: the concept of the *medium* of life, as the *biosphere*, and the concept of a *living natural body*. Living matter is found on our planet only in the *biosphere*, which is the domain of life.

This characterization defines the boundaries of the biosphere with absolute precision. According to this definition,

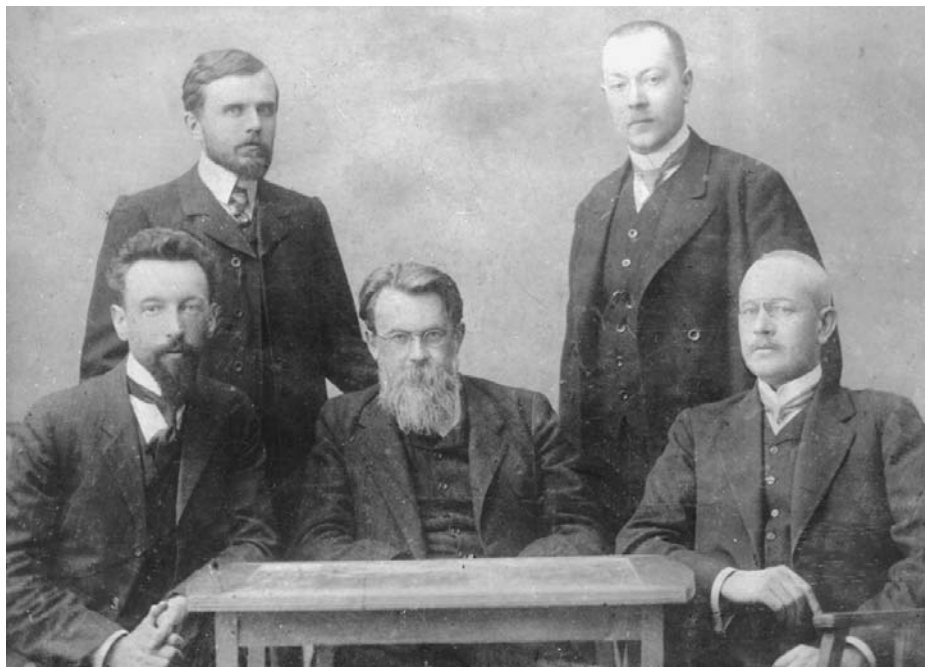

Courtesy of the History of Geology Department, Vernadsky State Geological Museum, Russian Academy of Sciences

Vernadsky and his protégés, around 1911. From left, seated: V.V. Karandeyev, Vernadsky, P.K. Aleksat; standing: G.O. Kasperovich, A.E. Fersman (the most famous of his followers).

the entire *troposphere* of the atmosphere belongs to the biosphere. And now, living organisms—human beings and their inevitable companions: insects, plants, and microorganisms—are penetrating even higher, by themselves or with mechanical assistance, into the *stratosphere*. At the same time, civilized humanity (together with its inevitable living companions) is penetrating several kilometers below the surface of the Earth, deep below the limits of that surface terrain, which is in contact with the troposphere. Today, too, we recognize the planetary significance of the discovery, at the end of last century, that life—chiefly anaerobic, microbial living matter—is to be found in subterranean regions more than three kilometers deep, and probably deeper. The lower boundary of the biosphere thus lies several kilometers below the surface of the geoid.⁴ The entire world ocean belongs to the biosphere.

The biosphere constitutes a definite *geological envelope*, sharply differentiated from all other geological envelopes of our planet.⁵ This is so, not only because the biosphere is populated by living matter having enormous significance as a geological force, completely reworking the biosphere and transforming its physical, chemical, and mechanical properties. In addition, this is the sole envelope of the planet, penetrated in an appreciable way by cosmic energy, which transforms it even more than living matter does. The main source of this energy is the Sun. The Sun's energy—thermal, light, and chemical [i.e., ultraviolet—trans.] energy—is, together with the energy of the chemical elements, the primary source for the creation of living matter.

Living matter permeates the entire biosphere and to a large extent creates it. Living matter accumulates the energy of the

biosphere, mainly the thermal and chemical energy of solar radiation and the chemical energy of the Earth's atoms. It is possible, that radioactive energy plays a certain role in this.⁶

4 Materially and energetically, the matter constituting the biosphere is acutely heterogeneous. From this standpoint, we must distinguish the main bulk of its matter, which does not belong to living matter, and which I shall call *inert*—nonliving matter. The greater part of this, in terms of weight, consists of solid rocks. But the greatest volume belongs to liquid and gaseous bodies—the ocean and the atmosphere. Here is found—here lives—the totality of the planet's living organisms—its living matter.

Between the living and inert matter of the biosphere, there is a single, continuous material and energetic connection, which is continuously maintained during the processes of respiration, feeding, and reproduction of living matter, and is necessary for its survival: *the biogenic migration of atoms* of the chemical elements, from the inert bodies of the biosphere into the living natural bodies and back again. This appears in the form of *motion*—the departure and arrival of specific chemical compounds and elements to and from living organisms in connection with the processes of feeding, respiration, excretion, and reproduction, characteristic of living matter. These processes define the *biogeochemical energy* of living matter, the chief manifestation of which is the multiplication of living matter.

All of these manifestations of biogenic migration and biogeochemical energy are determined by the dimensions, the chemical composition, and the energy of the biosphere. For this reason, not any arbitrary sorts of organism can exist in the biosphere, but only those organisms strictly determined by the structure of the biosphere. *The living organism and living matter are a lawful function of the biosphere.* People usually forget this. And, in an erroneous manner—especially in philosophical discourse, but also in biology—they counterpose the living organism to its environment, as if these were two independent objects. This sort of counterposition is a logical error. It is especially apparent in philosophy, and *undermines at the core a great number of its conclusions.* I shall not pause here to consider this point more fully.

5 No less important, is the concept of a *natural body*. Strangely enough, this basic concept, which in essence pervades all natural science, is usually ignored and not subjected to serious logical analysis. And yet, scientists use the concept, almost unconsciously, at every step of their work.

In my youth, I had a clear and conscious experience of its importance. My teacher V.V. Dokuchayev, in his creative work on soil science, put forward the proposition, that soil is a *special natural body*, distinct from other rocks. As is well known, he proved this thesis, and thus made it possible for his contemporaries to grasp, through a striking example of a successful synthesis, the bases of creative work in natural science.⁷

But such events are rare in the history of science and in current scientific life. Normally, debates do not address the fundamental assumptions of scientific knowledge. People

do not talk about these assumptions; they forget about them.

Reflecting on this, it is easy to convince oneself, *that all natural science is based upon the concept of a natural body, or a natural phenomenon.* In our further discussion, we shall deal only with the biosphere, and shall consider phenomena involving living matter.

Scientists study in the biosphere only those objects, which are created in the biosphere by forces occurring within the biosphere, or phenomena, produced in the biosphere by those forces. The objects they deal with, may conveniently be termed the *natural bodies* of the biosphere, and the phenomena—*its natural phenomena*. The task of science is to enumerate, describe, and identify all the natural bodies and all the natural phenomena, which exist or have existed in the biosphere. This is the work of generations of scientists, and there are billions of billions of scientific facts and scientific generalizations—i.e. natural bodies and natural phenomena—to be grasped in a scientific manner, counted, and brought into a system. These form the basis of science; from them, empirical generalizations are constructed, which can be brought back once again to the natural bodies and natural phenomena.

This work results in the creation of the basic content of science, for which, strangely, there is not yet any generally accepted expression. I have had to name it, and, perhaps, it is convenient to call it *the scientific apparatus*.⁸ This apparatus began to be created in astronomy already thousands of years B.C., and was understood—it came down to us—in the form of numerical data on the positions of the Sun, the stars, and the planets in the Hellenistic compendia (Hipparchus, Ptolemy). This work was revived in the Middle Ages in Central Asia. Everywhere, it was done in the chronicles in the form of precise records of comets, fireballs, meteorites, etc. Starting in the 16th century, there was a rapid accumulation of data, the evaluation of which was the basis for making the first major generalizations. But even in astronomy, the basic forward motion, which has been continuous and developing rapidly from that time on, began on a large scale only in the 18th century. In that century—the century of *descriptive natural science*—the effort to precisely enumerate, observe, and describe every natural body and to record every natural phenomenon, became a conscious task of exact natural science.

Linnaeus (1707-1778), basing himself on the work of earlier naturalists, introduced the concept of the *system of Nature* and for the first time calculated the number of species of animals and plants—the species of homogeneous forms of living matter, inhabiting the biosphere. In 1758, he knew a total of 4,162 species of animals (by 1768, the number was 5,936), and in 1768—7,788 species of plants. In all, Linnaeus had distinguished 13,724 species of living organisms by 1768, and even fewer rocks and minerals. Today, the number of species of plants is approaching 200,000, and may possibly exceed 300,000. The number of species of animals is approaching 800,000; in reality, it is probably several million and may reach 10 million. In essence, the *“system of Nature,”* understood in a broad sense, corresponds to what I call the scientific apparatus.

The colossal quantity of numerical data, corresponding to chemical and physical properties of matter—growing like a snowball, always increasing over the course of time, obtained mainly by *scientific experiment*, rather than from observation of the biosphere, and first created in the biosphere by scientific work, exceeding by many times the quantity of living natural bodies and living matter, and having no limits—in my opinion, makes it logically unclear, inconvenient, and practically useless to term these data a system of Nature. Therefore, the concept of *the scientific apparatus*, which we can appreciate, only because it has been reduced to a scientific system, is simpler. It includes both the system of Nature and the scientific apparatus of the humanities, which is encompassable by a scientific system, albeit thoroughly permeated by individuality.



Carl von Linnæus (1707-1778) introduced the concept of the system of Nature, and calculated the number of species of animals and plants.

6 Every object of natural science is a natural body or natural phenomenon, created by processes of Nature. At the present time many quadrillions, if not more, of natural bodies and phenomena have been scientifically collected, enumerated, and scientifically defined in the system of the scientific apparatus. The number of bodies and phenomena continuously increases, and the system of the scientific apparatus is also continuously being perfected. Thanks to this, we are confronted, ever more acutely, with an infinite quantity of scientific facts to examine. The basic content of science is located in them. Reworked by means of scientific generalization, provisional scientific hypotheses and theories, and embraced by mathematical deduction and analysis, these become *scientific truth*, the precision and profundity of which increases *with each generation*.

This is what distinguishes exact science from philosophy, religion, and art, where *there is no scientific apparatus* and where the scientific truth, sometimes discovered by intuitive creativity, can be recognized as such only when it has been scientifically validated. This creative intuition sometimes comes far in advance of its scientific comprehension, and it is in these domains of human creativity that the scientific truths of the future are hidden, which are unclear to contemporaries. But, we cannot make precise sense of them without science, without grounding them in the scientific apparatus.

7 It is possible to distinguish three types of natural bodies in the biosphere: *living* bodies (for example, a plant, a beetle,

etc.), *inert bodies* (for example, rock, quartz, etc.), and *bio-inert* bodies (such as soil, lake water, etc.).

The biosphere consists of sharply bounded domains, formed by living, inert, and bio-inert bodies—waters, living matter, rocks, air, and so forth. A transition from living bodies to inert bodies takes place when they die; when a living body ceases to exist as such, it is transformed into organogenic rock (for example, bioliths) and inert bodies such as gases.⁹ Bioliths are often bio-inert bodies. The direct generation of a living organism from inert bodies is never observed: the principle of F. Redi (all life comes from life) [*omne vivum ex vivo*], is never violated.¹⁰

The concept of inert (dead) and living natural bodies as sharply distinct natural objects, is a commonplace, ancient notion, inculcated over millennia of history—a concept of “common sense.” It cannot provoke any doubts, being clear

and intelligible to all.

In scientific work, even over centuries, only a few cases can be found, in which there were doubts about whether a specific natural object should be reckoned a living being or an inert body—whether that given natural phenomenon were a manifestation of the living or the nonliving. One such doubtful case—perhaps the most profound one—is the question of viruses.¹¹

Other cases may be the questions J.C. Bose has raised in Calcutta, about whether *life* is not manifest in both living and inert matter, but to different degrees. These are, however, philosophical problems, which Bose tried to solve using the scientific method, as G.T. Fechner had posed the matter less precisely, in philosophical terms, earlier in the 19th century in Europe. In this case, the question of biogeochemistry’s living matter is not involved, since in biogeochemistry, living matter is the totality of living organisms, whereas Fechner and Bose were trying to delve into the material-energetic substance, which is common to the living and the inert body.

8 The concept of a *bio-inert natural body* is a new concept—defined in exact biogeochemical terms and in distinction from the concepts of inert and living natural bodies. Natural bodies of this sort are clearly expressed in the biosphere and play a big role in how it is organized.¹² *Bio-inert bodies are characteristic of the biosphere.* These are lawful structures, consisting of inert and living bodies



Library of Congress

PASTEUR'S DISCOVERY OF OPTICAL ACTIVITY AS A DISTINGUISHING CHARACTERISTIC OF LIFE

In 1848, Louis Pasteur succeeded in separating, by hand, the left- and right-handed forms of tartaric acid crystals (a). Dissolving them in water, and examining the two solutions in a polariscope (b), he found that one solution turned the plane of polarized light to the left, and the other one to the right. He then showed that only the left-handed form is produced in biological processes, such as fermentation, while equal quantities of left- and right-handed forms (racemic solution) arise in laboratory synthesis of the compound.

simultaneously (for example, soils), all of the *physico-chemical properties* of which have to be adjusted—with sometimes very large corrections—if, in studying them, the activity of the living matter located within them is not taken into account.

The biogenic migration of chemical elements (atoms) plays a big role in their properties—very often the dominant role.

Any soil is a typical bio-inert body. V.V. Dokuchayev had already recognized this clearly.

The overwhelming majority of *terrestrial waters* are bio-inert bodies. There are only isolated instances, in which living matter does not play a fundamental role in them. This is not the case, for example, in hot volcanic waters, which are rich in sulphuric and hydrochloric acid, nor is it the case in strongly saline waters. Nonetheless, even in the Dead Sea there is microbial living matter, although it does not play a decisive role. Rain water is free of living matter in its first moments. All the waters of the oceans and seas, of rivers and lakes, and all of their *bottoms*, are bio-inert bodies. The gas balance, the chemical composition, and the silts of all these waters—their chemistry—is basically determined by living matter.

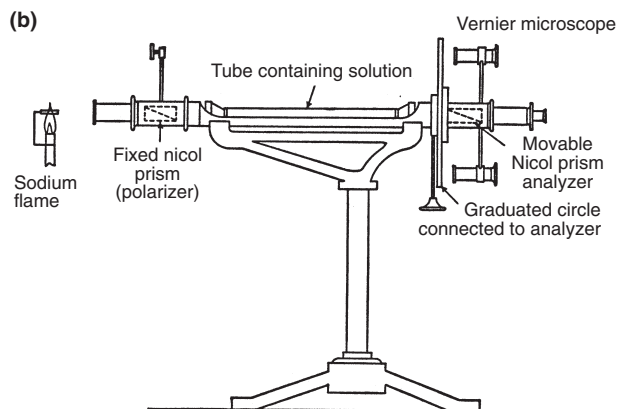
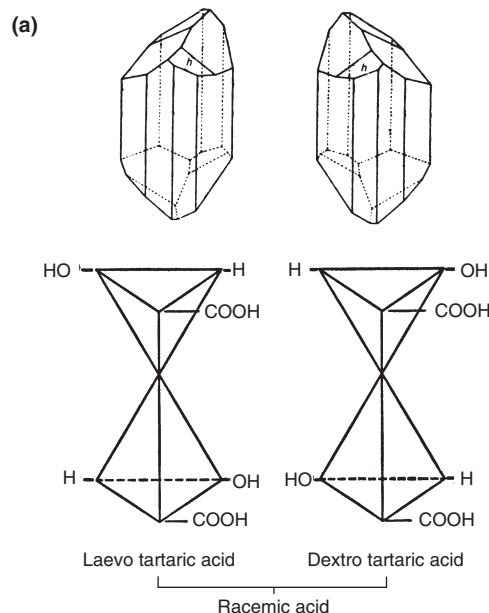

The role of bio-inert natural bodies is extraordinary, and has not yet been properly taken into account in how the biosphere is organized.

The process of *the weathering of rocks* is a bio-inert process—a fact that is usually not considered. This circumstance, I think, explains the backwardness of this area of chemical geology (the weathering of the Earth's crust) relative to the contemporary level of knowledge. The biogeochemical approach should contribute much to the solution of this problem.

9 So far, I have not gone beyond the concepts: living matter, the biosphere, natural bodies, and natural phenomena (inert, living, and bio-inert)—concepts based on the enormous empirical, precise material of experience and observation. These concepts cannot arouse any theoretical doubts whatsoever, nor do they require any new scientific hypotheses or theoretical scientific constructions to be understood. One can calmly proceed with the work, so fruitful for science, of systematizing the accumulated scientific facts and generalizing from them.

But, for an understanding of the matters that now follow, I must necessarily touch upon two new phenomena of great importance, the scientific investigation of which cannot be carried out on the basis of the mere generalization of scientific facts, but requires introducing new concepts and finding a new form of comprehension of the facts. Both of these phenomena are extremely poorly understood from a theoretical standpoint, and their scientific significance has not been appreciated. They are now on the frontier of contemporary scientific knowledge. These are, first, the concept of *right- and left-handedness* and, second, the concept of *biogeochemical energy*.

Right- and left-handedness is an everyday concept, existing since the earliest times, which has hardly been comprehended in a scientific and philosophical way. It was Louis Pasteur, who first drew attention to its paramount importance for understanding the phenomena of life—the living organism, or living matter. Independently of Pasteur, and somewhat earlier, Bechamps had realized this, but Pasteur grasped the question more deeply, and identified within it phenomena, which permit us to penetrate in a precise scientific way into this immense domain of problems, the full significance of which Pasteur himself could not foresee.

The concept of *biogeochemical energy* was introduced by me in 1925, in my report to the Rosenthal Foundation in Paris, which was never published in full. In my book, I deal with this question to the extent possible today. Let us first examine the question of right- and left-handedness in its relation to living matter and to the biosphere.

10 We do not need, here, to deal with the profound naturalist and experimenter A. Bechamps—an older contemporary of Pasteur, his enemy and rival, who outlived Pasteur by many years, but was unable to obtain the conditions needed for systematic work. He started out from exactly the same fact, as did Pasteur—from the discovery, made at the beginning of the 19th century, in a small enterprise in Alsace, of the transformation of racemic acid or its salts into left-tartaric acid during the development of wine mold in it. On this basis, a new way of producing left-tartaric acid was established. Pasteur and Bechamps—both profound chemists—saw in this chemical action of the mold as living matter, a remarkable, exclusive property of life—living matter; something not understood, unusual, unknown and, apparently, impossible in ordinary chemical reactions. To reflect upon this and to take note of it—to see the problem involved—was already a big accomplishment, but it was only the first step. It was necessary to investigate the phenomenon, and express it, in specific scientific facts.

Bechamps's circumstances of life did not permit him to do this. But Pasteur connected the new phenomenon with a very special property of enantiomorphous crystals, characterizing—under the influence of living matter—the racemic acids and salts. As a result of that action, an isomer was produced—only the left- or the right-handed one, but not the other, which had perhaps been consumed by the organism. Pasteur correctly saw in this a drastic violation of the law of crystalline symmetry. This violation appeared in the fact, that

the right- and left-handed forms manifest completely different degrees of stability in living matter, exhibiting *far from identical chemical behavior*—something never observed with them in inert natural bodies. Evidently, the latter could not occur.

He called this phenomenon *dissymmetry*, but did not draw attention to, and did not connect this with the normal right- and left-handedness of living matter, in its morphological and physiological structures. He studied the phenomenon as a crystallographer and a chemist, but not as a biologist. Pasteur himself did not provide a more precise definition of dissymmetry and did not consider the changes, which had occurred in crystallography, when he returned to these problems again in the last years of his life.

Much more important, was Pasteur's discovery of *molecular dissymmetry*, completely analogous to the dissymmetry of polyhedral crystals. He thereby initiated a whole new science—stereochemistry. Because of it, chemistry was enriched by the concept of *asymmetry* (i.e. the absence of symmetry in the spatial configuration *in the vicinity* of a carbon atom). This term is used simultaneously in chemistry and physics in completely different senses, generating confusion.

11 The muddle that arose interfered with the work. The molecular dissymmetry, discovered by Pasteur, showed, that the presence of living matter is reflected in the chemical formula, including in solutions, and that *right- and left-handed atomic structures* are found to be non-equivalent in chemical reactions. *They are chemically distinct in living matter, but chemically identical in inert chemical media.* Pasteur did not know, that (as was discovered after his death) this was essentially the same phenomenon he himself had discovered in crystals. For in crystals, he had a spatial distribution of right- and left-handed spiral arrangements of *atoms*, analogous to the atomic structure in molecules. This conclusion emerged in a precise way from the notion of *crystalline space*—speaking in contemporary language—geometrically constructed by Ye.S. Fyodorov and A. Schoenflies at the end of the last century. In the coincidence of the 230 groups he identified (there are actually 219), with the arrangements of atoms in crystalline space, Ye.S. Fyodorov saw proof of the atomic construction of chemical compounds. Finally, this was experimentally demonstrated in the 20th century by the X-ray analysis of crystals. The contemporaries of Pasteur—Seeber, Ampère, and Godin—had foreseen this, but Pasteur remained outside the influence of their ideas.

After Pasteur, P. Curie generalized the concept of dissymmetry, considering the phenomenon, discovered by Pasteur in living organisms, as a special case, and applying the concept of dissymmetry to physical phenomena in general—electric and magnetic fields, etc.—as a fundamental postulate of physics. But Curie was not able to complete the development of his ideas; his work was interrupted in full swing, by his sudden death. No coherent presentation of the results he had obtained was left in his papers. It should only be noted, that Curie demonstrated the existence of different forms of “dissymmetry,” and logically concluded that a phenomenon, connected with any given form of dissymmetry,



Courtesy of the History of Geology Department, Vernadsky State Geological Museum, Russian Academy of Sciences

The Russian delegation on the way to the International Geological Congress in Canada, 1913. The photo is taken on the deck of the Empress of Britain, en route from England to Canada. From left, seated: Ya.V. Samoilov, F.Yu. Levinson-Lessing, Vernadsky, F.N. Chernyshev, B.L. Stepanov; standing: M.M. Lyuboshinsky, V.F. Levinson-Lessing.

must have a cause that possesses the same form of dissymmetry. It is convenient to call this conclusion *P. Curie's principle*.

In view of this state of the matter, I think it will be more correct to leave aside the concept and the word "dissymmetry," and instead employ the older, generally familiar idea of the distinction between right- and left-handedness in organisms, which is so starkly manifested in Man. But since there exists a theory (an erroneous one, it seems to me) that right-handedness in Man emerged only in the Neolithic period, the correct way to proceed will be to substitute for right- and left-handedness, the more general concept, which Curie employed before his death, of *distinct states of space*. He did not manage to prepare a formal presentation of this concept before his death, but it essentially corresponds, of course, to the different forms of dissymmetry, one on which Curie and Pasteur were working.

This concept was widely known among naturalists in the domain of descriptive natural science, and is rooted far back in the 18th century. Here the subject was often the variable state of space on our planet, connected with its orbital motion around the Sun; that certain motions and phenomena were different, according to whether they took place on a part of the planet moving in the direction of the Sun, or in the opposite direction. Pasteur recognized the possibility of *different states* of cosmic space, by which he explained his discovery that living matter exhibits dissymmetry. Indeed, we should see in the state of space, the basic *geometrical substrate* for all of its material, temporal, and energetic manifestations.

In the present case, there will be a state of space, in which right- and left-handedness, expressed as right- or left-handed

spiral structures of atoms, are chemically identical in inert bodies and distinct in living ones. This, one of the most profound geometrical properties of natural bodies, has been given insufficient attention, in philosophy, mathematics, and natural science. But we are all very familiar with it in daily life. We know it from childhood, since a human being is a living body, in which right- and left-handedness are sharply distinguished from one another (including in chemical terms). For example, one person out of 16,000 [sic] is left-handed. In recent times these phenomena have begun to attract greater, but in my opinion still insufficient, attention in biology.

Mathematicians—especially geometers—can no longer ignore this, but need to elaborate this fundamental *geometrical phenomenon*.

I shall return to the question of the state of space, in general, and in connection with its particular manifestation in the non-equivalence of right- and left-handedness, in my next study on the problems of biogeochemistry. Here I cannot go into it further. It seems to me that it is convenient to speak, in this context, about physical space, as Helmholtz proposed.

12 It is necessary to discuss yet another phenomenon, which has hardly been comprehended by scientific generalizations—the *active energy of living matter in the biosphere*. R. Mayer, almost 100 years ago, took this manifestation of living matter under consideration. He showed that in organogenic minerals—in coal deposits—we have an accumulator of free energy, captured in this form by the living matter of the Carboniferous period, and we use the fossilized solar rays of that time. But the idea in general form—the creation and accumulation of *free energy in the biosphere* by

living matter and by the natural processes associated with living matter—arose in the minds of many in the middle of the 19th century, when the concept of energy itself was developed.

Now I want to address this more concretely: not as the basic question of the energetics of the planet, but as a biogeochemical problem. In 1925, I designated the free energy exhibited by living matter in the biosphere, which essentially amounts to the work, associated with the motion of atoms, and is manifested in the movements of living matter, as *biogeochemical energy* (See Section 15, V). Since biogeochemical energy sharply distinguishes living matter from inert matter, it is indispensable to mention its basic features here.

13 The biogeochemical energy of living matter is closely linked with three fundamental characteristics of living matter in the biosphere: first, with *the unity of all living matter in the biosphere*; second, with the continuous generation, by living matter in the biosphere, of *free energy, capable of performing work*; and third, with *the colonization of the biosphere by living matter*.

In all three of these cases, the manifestation of biogeochemical energy is different; *taken as a whole, biogeochemical energy is inhomogeneous*. In the final analysis, it is connected with the movement of living matter in the biosphere, with passive or active displacements (relative to living matter), associated with the mobility of masses of living matter in the biosphere, and ultimately reducible to the motion of atoms or chemical elements.

From what I have said, it is clear that biogeochemical energy is not some special form of energy pertaining to life; it is not the *vital energy* that W. Ostwald was looking for—analogueous to thermal, chemical, light, electrical energy, etc. It does not affect the law of conservation of energy, but appears in that context as *already known forms of energy*.

We can now trace the real sources of biogeochemical energy with precision. They are, ultimately, the radiant energy of the Sun (light, heat, chemical, and the energy of the chemical elements, from which bodies of living matter are constituted (chemical and thermal energy). There is probably a contribution from radioactive elements.

An exact quantitative calculation of the caloric effect in life processes, I believe, establishes beyond any doubt that such is its origin. It is, essentially, a result of *the organization of the biosphere and the organization of the living matter* that inhabits the biosphere.

I cannot go into this matter further here. I shall only mention the main forms of manifestation of that organization. The most important is *the biogeochemical energy, connected with the colonization of the planet*. I attempted to calculate it in the form of a definite, for each species of living matter, maximum *velocity of that species' transmission of life*—the perhaps unsuccessful definition I gave it earlier; that is, *the velocity of colonization of the entire planet by a given organism*. This is energy, connected with the *reproduction of living organisms*. Each form of living matter can in this way spread throughout the planet and, within a certain period of

time, which is different for each form of living matter, theoretically colonize the entire planet. In the most rapid cases, for bacteria, this process of colonization can occur within one to one-and-a-half days; while for the elephant—one of the slowest-reproducing of all organisms—it would take 1,000 to 1,100 years. At full colonization, the living matter would cover the entire surface of the planet, i.e., it would fill all of its actually existing lines and areas. One of these curved lines, the line of the Earth's equator, i.e. the precisely defined terrestrial line (curve) of maximum length, may be taken as a single parameter for comparison, common to all forms of living matter.

When I speak here about the colonization of the planet, I assume that this process of colonization were to occur under such conditions, as would permit it to proceed normally into the future, if it were not hindered by lack of space—of surface area for colonization. The velocity of colonization, expressed as a magnitude V , may fluctuate within limits ranging from close to the speed of sound in air, more than 33,000 centimeters per second (for some bacteria), to hundredths of a centimeter per second (for the elephant).



Courtesy of the History of Geology Department, Vernadsky State Geological Museum, Russian Academy of Sciences

Vernadsky's gravestone in Novodevichye cemetery, Moscow. The sculpture is the work of Z.M. Villensky in 1953; the photo was taken by Yu.Ya. Solovyov.

In other words, we are talking about the long-term, durable colonization of the planet by an organism under its normal conditions of life, in which it can exist over generations; and not about *explosions* of life, in which the excess of organisms born, dies out due to insufficient food or living space.

These conceptions have not yet entered into the consciousness of science. I am convinced that their employment is a matter for the future. It should be noted, that the velocity of sound corresponds to the real condition, wherein the normal composition of the atmospheric medium, in which the organism lives—even in the case of aquatic organisms (natural waters have their own underwater atmosphere)—, is not destroyed. This shows that biogeochemical energy, so expressed, has nearly reached its physical limits. The velocities obtained in this way may be quantitatively compared with one another; it can be asserted, for example, that the velocity of colonization for the elephant is 10^7 times less than for bacteria.

But the biogeochemical energy of colonization does not subsume all the manifestations of that energy. I shall mention two more of its forms here.

First, the creation of *a mass of a living matter and its maintenance*, by the metabolic process, *at a constant value* during the period of the organism's existence.

And, second, the enormous new form of biogeochemical energy, constituted in the biosphere by the technical

work process of the human race, which is directed in a complex manner by human thought—consciousness. It is remarkable, that the growth of machines within the structure of human society, also proceeds in a geometrical progression over the course of time, just as does the proliferation of any living matter, including human beings.

These manifestations of biogeochemical energy have not been scientifically investigated at all.

It is imperative to direct scientific work into these areas of biogeochemistry, not only because of their great theoretical significance, but also, it seems to me, with a view towards their certain importance for the tasks of the state. In biogeochemistry, it is necessary to make a deliberate approach to the spontaneous process of the biosphere's transformation into the noosphere, which is now taking place.

For this, the paramount task is to assemble facts and study the problems connected with biogeochemical energy. I have no doubt that this will be done sooner or later. I hope to come back to it in my book.

The basic, distinctive feature of biogeochemical energy is clearly and forcefully demonstrated in the increase of *the free energy of the biosphere* over the course of geological time, and is evident in an especially drastic manner in the transition from the biosphere to the noosphere, which is now apparent.

II. Table

The Fundamental Material-Energetic Distinction of the Living Natural Bodies of the Biosphere from Its Nonliving Bodies

The distinction of the energetic processes of living matter from those of inert matter is located in the context of the same forms of energy, as appear in inert natural bodies. The chemical composition of both types of natural bodies comes down to the same chemical elements—although it is possible that the atomic weights of some or all of the elements are shifted in living matter. This fundamental distinction is observed in the space-time of forms of living matter. It is indispensable also to study, alongside matter and energy, the manifestation of time in living processes. The scientific hypothesis of a special geometrical structure of space for bodies of living matter is admissible, and requires verification—a space not corresponding to Euclidean geometry, but lying at the basis of the material-energetic and temporal properties of living matter, distinguishing it from the inert natural bodies of the biosphere.

14 On the basis of everything that is currently known about the biosphere, I shall now attempt to express concisely, *without any theories or hypotheses*, that sharp distinction between the living matter of the biosphere, and its inert natural bodies, which is so pronounced and characteristic for the envelope of the Earth, most familiar and closest to us. It seems to me, that

this is necessary and important to do right now, before the publication of my book—whenever that might occur. As far as I know, this has never yet been done in such a form and aspect; consequently, it could never before be discussed as a whole—the most important problem lies outside the naturalist's field of vision.

It is extremely important, for naturalists to think about understanding such a fundamental phenomenon in the biosphere.

It is important for them to have at their disposal, not so much the theoretical scientific-philosophical conceptions of life, which today occupy the thought of philosophers, as those exact data, which subsume biology and all of its "definitions of life," grounded in those data.

In the table provided below, I believe I am giving only such empirical generalizations, and that I do not depart from the domain of scientific facts. This is the side of the question, to which attention must now be turned, and these generalizations should be taken as the basis for scientific work.

15 The acute, unbridgeable distinction between living natural bodies and inert natural bodies of the biosphere can be summarized in condensed form in the following table.

The Fundamental Material-Energetic Distinction of the Living Natural Bodies of the Biosphere from Its Nonliving Bodies

Inert Natural Bodies

Living Natural Bodies

I.

Among the *dispersed* inert natural bodies of the biosphere, there are no bodies analogous to living bodies. Dispersed inert forms are concentrated in the biosphere, just as living forms are, but the former penetrate to greater depths. Still deeper, evidently in the granite layer of the crust, their existence is stifled by the great pressure.

These inert bodies are created in the biosphere by the death of living matter (for example, microscopic organisms), from their secretions and excretions, through the motion of gases or liquid phases, in winds, moving waters, oils, etc. They are also brought into the biosphere from its lower regions by gases or liquids, volcanic explosions and eruptions, and tectonic movements of deeper layers of the Earth's crust. They are created by ordinary physico-chemical processes and can be synthetically reproduced in our laboratories.

Inert dispersed bodies—cosmic dust and meteorites—penetrate the biosphere constantly and continuously from the expanses of cosmic space, partly from the galaxy.

Living natural bodies exist only in the biosphere and *only as dispersed bodies*, in the form of living organisms and their aggregates—living matter. They are observed in both the macroscopic (gravitational field), and in the microscopic cutaway views of reality.

The artificial synthesis of a living natural body has never been accomplished. This indicates that some fundamental condition is required for such a synthesis, which is absent in the laboratory. L. Pasteur identified dissymmetry—a special state of space—as the missing condition (Sections 10-11).

The penetration of living natural bodies into the biosphere from cosmic space is conceivable, but has not been proven so far.

II.

Inert natural bodies are extremely diverse and, taken as a whole, manifest no unifying genetic connection among them.

The inert natural bodies of the biosphere have no common, unifying feature analogous to the cell, protoplasm, and reproduction—features common to all living natural bodies.

Living natural bodies represent a unified *whole—the living matter of the biosphere—both morphologically, having a single morphological unit—the cell; as well as in their material structure, having the same protoplasm; and, finally, in dynamic terms, as always possessing the ability to reproduce.*

It can hardly be denied, that such a unity of all living natural bodies, is connected with their genetic unity in the course of time.

III.

In inert natural bodies and natural phenomena, there is no distinction in the chemical properties between the left- and right-handed forms of one and the same chemical compound. In inert bodies these are chemically identical. Right- and left-handedness are subject to the strict laws of symmetry for homogeneous solids (monocrystals). In particular, the quantities of right- and left-handed monocrystals of one and the same chemical compound, formed simultaneously in an inert medi-

A chemical distinction between right- and left-handed forms of the same chemical compound, characterizes the state of *the physical space*, occupied by the body of a living organism, and its manifestation in the surrounding medium, in the biosphere. This chemical non-identity is strongly manifested in the solid (crystalline and mesomorphic) and liquid products, formed by biochemical processes. Either right-handed, or left-handed isomers predominate. This phenomenon is acutely and profoundly manifested in the properties of the living matter of the biosphere, right down to the molecules which make up living bodies. The

Inert Natural Bodies

um—are identical. “Dispersed droplets,” i.e. homogeneous crystalline polyhedra—individual specimens of a solid chemical compound—may differ strongly in their internal structure from the usual (isotropic) space of Euclidean geometry, but they do not depart from the framework of that geometry.

Right- and left-handedness are geometrically and chemically identical in inert natural bodies. Both are always present in the same number, and are chemically indistinguishable. One can state, that this chemical identity of the right- and left-handed forms, is a necessary *manifestation* of the *atomic* construction of homogeneous, solid chemical compounds, and of Euclidean physical geometrical space, materially expressed in this way. It is a manifestation of the atomic construction, on the one hand, and of Euclidean geometry, on the other.

Living Natural Bodies

laws of symmetry for the solid crystalline state of matter are violated in a drastic manner.

Such states of space, occupied by bodies of living matter, are created in the biosphere only out of previously existing living natural bodies. They are generated by *birth* (Redi’s principle).

One can see here an expression of Curie’s principle (Section 11).

It appears that L. Pasteur was right, that *for the primary chemical compounds, essential to life, only the left stereo-isomers* exist inside the body of a living organism (in its physical space); the right-handed isomers either do not appear, or are eliminated by the organisms. Unfortunately, until now this enormously important phenomenon, which could easily be established, has still not been verified, and remains only very probable.

IV.

New inert natural bodies are created in the biosphere by physico-chemical and geological processes, irrespective of earlier existing natural bodies, living or inert; they are formed via innumerable pathways from natural bodies, which usually do not resemble the resulting product.

Inert bodies can be formed within living natural bodies. But there is nothing resembling reproduction in the creation of inert natural bodies in the biosphere.

There is no kind of change in inert natural bodies of the biosphere, analogous to the evolutionary process of living matter. Generally speaking, we see in the biosphere today the very same inert natural bodies and the same phenomena of formation of such bodies, as have existed over a period of at least two billion years. In the course of geological time, new inert bodies emerged only under the influence of the evolutionary process of living matter. The creation of such new inert bodies is occurring in a drastic and powerful way—and their significance is growing—in the *noosphere* of the present epoch, as a consequence of human creativity.

A new living natural body, a living organism—is born only from another living organism like it. For each species of living matter there is an alternation of *generations*, coming to be at a certain definite rate over time (Redi’s principle).

In geological time, in the course of at least two billion years, living matter has been *plastic*—there is a process of *evolution of species*. Evidently, according to laws that have not yet been elucidated (processes of mutation, in part?), a new *species* of living matter is created from time to time; in various living organisms, a new generation appears, which is morphologically and physiologically changed, and clearly different from the preceding generation. A *single, unified evolutionary process*, closely connected with the history of the planet, is observed over the course of not less than two billion years. As shown by Dana (1852), there is a process of formation, within the living matter of the biosphere, of functionally more and more powerful central nervous systems—of the brain. This process moves forward inexorably over the course of time, but with major interruptions on the order of tens, or perhaps hundreds of millions of years.

Thanks to this, from the end of the Pliocene the geological role of living matter in the biosphere abruptly increases—making a jump. Thanks to human creativity, the biosphere is rapidly shifting into to a new state—the *noosphere*.

V.

A dispersed inert natural body—solid or mesomorphic—has no special properties of motion as a single natural body. There are also no such properties in liquid or gaseous inert bodies, which consist of molecules in complex motion

There are no liquid or gaseous living natural bodies in the biosphere. The liquids and gases existing in any living body are mixed with colloidal—mesomorphic and solid—structures.

Spontaneous motion, to a large degree self-regulating, is one of the marks of any living natural body in the biosphere.

Inert Natural Bodies

and which assume the form of the containers in which they are located. Gaseous bodies exert pressure on the walls of closed containers. Their motion is governed by the laws of temperature and pressure.

Living Natural Bodies

There are two forms of such motion for living matter. One—*passive*—occurs through reproduction, and is a *common property of all living matter*. The other—*active*—is expressed for the great majority of animals, and for a minority of plants, as the spontaneous movement of individuals and their colonies in *the medium of living matter*.

The first form of motion—spreading in the biosphere, or *colonization of the biosphere*—is analogous, in the nature of its laws, to a gaseous mass, and, like such a gas, it exerts pressure, the magnitude of which depends on the rate of reproduction (the biogeochemical energy of the colonization process). The rate of colonization by living matter within the boundaries of the biosphere approaches a physical maximum—*the speed of sound in the gaseous medium of respiration*.

For microscopic organisms, living in liquids, there is yet another form of motion, which matches the molecular motion of fluids, visible to us in Brownian motion.

VI.

Inert natural bodies are absolutely inert. They change as a result of external causes, being weathered in the biosphere. This bio-inert process proceeds slowly and is manifested in the course of geological time. Inert bodies do not grow and, apparently, do not increase their mass.

For inert bodies, we find nothing analogous to the *growth* (and proliferation) of living organisms.

To liken the growth of an organism to that of a crystal, is a misunderstanding, as becomes clear upon the first encounter with logical analysis. The atoms of an inert body do not manifest, inside it, any characteristics of motion, analogous to the biogenic migration of atoms.

Living natural bodies live, i.e. *grow and multiply*.

Thanks to this, each living organism is the source and center of a *biogenic migration of atoms* from the biosphere into the organism and back again. Thereby each organism is a source of *free energy in the biosphere*—free biogeochemical energy.

Biochemically, this biogenic flow of atoms creates an innumerable and continuously changing quantity of chemical molecules in living matter. Most of the chemical compounds generated in living organisms, can be synthesized by different means in the laboratory. But in the biosphere, almost all of those compounds are formed *only* in living matter.

Their synthesis occurs within living matter at rates which are unheard of and not yet achievable in our laboratories.

Thanks to this, biogeochemical energy appears in the biosphere, in terms of its power, as the fundamental force of change of the biosphere.

VII.

The number of inert natural bodies in the biosphere is determined by the general properties of matter and energy. It does not depend, in any explicit way, on the dimensions of the planet.

The biosphere continuously absorbs and emits matter and energy from and to cosmic space. There exists a continuous matter-energy exchange of inert natural bodies.

Apparently, we see here an established dynamic equilibrium—a manifestation of the same sort of organization (but not mechanism) which is characteristic of the biosphere and living matter.

The number of living natural bodies of the biosphere is quantitatively connected with the dimensions of the biosphere.

The scientific working hypothesis is admissible, but requires verification, that an extraterrestrial exchange of living natural bodies occurs.

VIII.

The size of the area occupied, and the regions in which inert natural bodies appear in the biosphere, are limited by the dimensions of the latter, and can only increase with the expansion of the biosphere.

Evidently, the biosphere expands in the course of geological time, through the motion of living matter. In this process the inert natural bodies of the biosphere play a passive role.

The mass of living matter of the biosphere is close to the limit and, evidently, remains a relatively constant value *on the scale of historical time*. It is determined, above all, by the radiant energy of the Sun, falling on the biosphere, and by the biogeochemical energy of the process of colonization of the planet.

Evidently, the mass of living matter increases in the course of geological time, and the process of the occupation of the Earth's crust by living matter has not yet been completed.

IX.

The minimum dimensions of an inert natural body of the biosphere are determined by the degree of dispersion of matter and energy—the atom, electron, neutron, etc. The maximum dimensions are determined by the dimensions of the biosphere—a bio-inert natural body. The range of sizes is enormous— 10^{40} or, probably, even more.

The minimum dimensions of a living natural body are determined by *respiration*, i.e. the gaseous biogenic migration of atoms (and, in the final analysis, by the Loschmidt [Avogadro] number). These dimensions are of the order of 10^{-6} cm. The maximum dimensions have not exceeded a few hundred meters in the course of two billion years. The reasons for this have not been ascertained. The range of sizes is not large: 10^9 .

X.

The chemical composition of inert natural bodies of the biosphere is a function of the composition and properties of the surrounding medium *in which they are created*. It is determined in a passive manner by the structure of the biosphere in the course of geological time.

The chemical composition of living natural bodies is created *by those bodies themselves*. Through nutrition and respiration, they select the chemical elements they need for their existence and for the creation of new living natural bodies (the autarchy of living matter). Evidently, in this process they can change the isotopic ratios (change the atomic weights of the chemical elements) in mixtures.

Thus, living organisms create the greater part of their own bodies, as independent and autonomous (within certain defined limits) bodies in the biosphere—the large bio-inert body of the planet.

XI.

The number of different chemical compounds—molecules and crystals—in inert natural bodies of the biosphere (and the Earth's crust) is *limited*. There exist a few thousands of such molecules and crystals. This determines the essentially small number of forms of inert natural bodies of the biosphere.

The number of chemical compounds—molecules and crystals—in living natural bodies is *unlimited*. It is connected with individuality, and is different for each individual unit of living matter. We already know *millions* of species of organisms and *millions of millions* of different molecules and crystal lattices, corresponding to them. Although far from all of them have been described, this character of theirs is beyond any scientific doubt.

XII.

All natural processes in the domain of natural inert bodies—with the exception of radioactivity—reduce the free energy of the biosphere (physico-chemical processes are reversible). In this way, the *free energy* of the biosphere is diminished and its *entropy* is increased.

Natural processes of living matter, as reflected in the biosphere, increase the free energy of the biosphere (i.e., decrease its entropy).

As a result of that process *the free energy of the biosphere increases*, thus showing the fundamental importance of living matter in the structure of the biosphere—and thereby the planet.

XIII.

The chemical composition of inert natural bodies may correspond to an almost theoretically pure chemical compound, with precise stoichiometric proportions among the elements. In minerals, solid solutions predominate (isomorphic mixtures).

Free atoms of chemical elements are dispersed in all inert bodies. These penetrate all terrestrial matter, not entering into the composition of the molecules, and not always entering the nodes of the spatial lattices.

Today we know of two continuously occurring processes, causing the *dispersion of atoms*: the penetration of (cosmic) radiation, and radioactive processes, which cause a an uninterrupted dispersion of atoms—always ephemeral—in the terrestrial inert matter of the biosphere. The significance of this phenomenon is just beginning to dawn upon us. It demands theoretical and experimental study.

In the living matter of the biosphere, we always find extraordinarily complex mixtures of chemical molecules. These are always bodies of mesomorphic structure (colloidal, and more rarely crystalline, etc.). *Molecules of water*, chemically and physically bound and retaining their characteristic properties to a great extent, overwhelmingly predominate (outside the stages of the latent states of living matter). They constitute 60 to 99 percent (or possibly more) of the total weight of living matter. In latent states of living matter, the amount of these molecules ranges between 4 percent and 15 percent (possibly less).

There are no stoichiometric proportions in the gross chemical composition of living bodies. But their chemical composition is strictly determined, and more constant than the chemical composition of isomorphic mixtures in natural minerals. This composition is typical for a given *species, race etc., constituting a characteristic signature of each form of living matter*.

In this respect, there are no special biogenic chemical elements for living matter as a whole. All the elements of the biosphere are embraced by living matter. But it is characteristic, that for every chemical element its geochemistry in the biosphere involves the existence of living organisms, whose activity concentrates that element, and which are thereby distinguished from other living organisms. *Here the role of living matter is clearly of a planetary character*.

It is evident, that the elements of water—oxygen and hydrogen—dominate in the overwhelming mass of living matter. Besides them, the dominant elements in protoplasm (C, N, P, S, K, Na, Cl, Ca, Fe, Si, Mg, etc.) must be characteristic of all organisms. The elements in skeletal structures, perhaps, play an even more important role in the biosphere in general: Fe, Ca, Mg, P, S, N, C, H, O, Mn, Si.

The number of chemical elements *necessary* for each species of matter, for its prolonged, normal life, is rapidly increasing as it is studied, and has now reached a total of 60 most studied ones. Without them, normal, prolonged existence is impossible. Dispersed elements (chiefly the so-called trace elements) often play a primary role. It is conceivable, that the number of elements in each living organism exceeds 80.

The phenomena of dispersion of chemical elements appear here, as they do in inert natural bodies. This process evidently is not limited to the planet's matter.

XIV.

With the exception of radioactive decay, isotopic composition (for the terrestrial chemical elements) does not change in inert natural bodies of the *biosphere*.

Evidently, there exist natural processes *outside the limits of the biosphere*—for example, the movement of gases under high pressures and at high temperature in the Earth's crust—which can shift the isotopic ratios.

These shifts do not violate the basic constancy,

Evidently, a shift (within certain ranges) in the isotopic composition (atomic weights) inside living organisms is a *characteristic property of living matter*. This has been proven for hydrogen, carbon, and potassium, and is probable for oxygen and nitrogen. This phenomenon calls for precise investigation.

It is becoming more than probable, that a chemical element, upon entering a living organism, changes its isotopic composition.

Since this process must be connected with an expenditure of energy, we should expect to observe, in the biogenic migration of

Inert Natural Bodies

in first approximation, of atomic weights, since those meteorites (galactic matter) which have been studied give the same atomic weights, with accuracy to the second decimal place.

One of the most important tasks of geochemistry at the moment is to obtain a more precise definition of the atomic weight of chemical elements in inert bodies, than is possible through chemistry.

Living Natural Bodies

chemical elements, which links together the living and inert matter in the biosphere, a considerable delay in the exit of these elements from the cycles of biogenic migration.

This phenomenon was noted by K.M. von Baer for nitrogen a long time ago. It is possible, that it is a general phenomenon.

XV.

The overwhelming majority of solid and mesomorphic natural bodies of the biosphere are characterized by their stability in the course of geological time—more than two billion years. This explains the small number of types of such bodies. W. Bragg correctly pointed out, that among crystalline structures (and, obviously, molecules) of the Cosmos, only the most stable and firm have persisted over the course of time. It seems to me, that we can see in this fact the result of an extremely long-term state of the Cosmos, which we are studying.

The study of the radioactivity of crust rocks shows, that the atoms of the basic material of the lithosphere *have not moved from their relative positions in the course of hundreds of millions, up to two billion years, while remaining the whole time in motion.*

The picture changes totally when we look at the living bodies of the biosphere.

A huge majority of these change in form through the process of evolution, and transform into other species or races of living matter. *This is a manifestation of time, in the living matter of the biosphere.*

This phenomenon is rather more complex than we imagine it to be in our understanding of evolution, since the evolutionary process has not yet been expressed in quantitative terms and its rate of change has not been quantitatively estimated (which is now possible). Despite the plasticity of living matter, there are cases of some organisms that are completely fixed. The organism does not change its morphological-physiological structure, remaining in the contemporary biosphere a living witness of the biosphere's past. Here we are talking about hundreds of millions of years (for Radiolaria from the Algonkian era and Lingulae from the Cambrian period—more than two billion years). Unfortunately, this *phenomenon of morphological constancy*—these persistent life forms—has not yet been studied by biologists.

Evidently, a continuous migration of atoms occurs inside living bodies, sharply contrasting with their immobility inside inert atomic structures over the course of time. The method of [radioactively] tagged atoms is beginning to reveal to us a new process of continuous biogenic substitution within the molecules, in which atoms of one and the same kind are exchanged—*an uninterrupted intramolecular biogenic flow of atoms.*

XVI.

All physico-chemical processes in inert natural bodies are reversible in time.

The space, in which they occur—the space of Euclidean geometry—is in an isotropic or anisotropic crystalline state.

The physico-chemical processes, which create living natural bodies in the biosphere, are irreversible in time. It is possible, that this will turn out to be a consequence of a special state of space-time, having a substrate that corresponds to a non-Euclidean geometry.

At the moment, this may be put forward as a scientific working hypothesis, to be verified. From this hypothesis the possibility follows logically, that there exist, *in our reality, phenomena of the transition of geometrically different states of space, one into another. The existence of the living matter of the Earth's biosphere is one such manifestation.*

III. Supplementary Explanations

The admissibility of the conception of different states of space-time existing simultaneously in the biosphere. Its geometrical heterogeneity. In the biosphere, time should be studied in the same way as matter and energy. The working hypothesis of a special geometrical state of the living matter of the biosphere, corresponding to one of the Riemannian geometries.

16 Analyzing the above Table (Section 15), we see that the distinctions between living and inert bodies in the biosphere can be reduced to three basic parameters: (1) differences in energetic characteristics, (2) differences in chemical characteristics, and (3) differences in space-time characteristics.

It seems to me, that the first parameters do not require any special interpretation from the standpoint of scientific work. When the point of departure for the explanation of Nature was Man, it was inevitable that Man be taken as the standard of comparison, leading to acceptance of the primacy of philosophy over science. In this connection, people thought they saw in living natural bodies the manifestation of a special *vital force* (this came from pondering mental processes), which sharply and definitively distinguished living from dead. I leave aside the even earlier, animistic views. All of these conceptions, both new and old, have departed, or are departing, from the domain of modern science into the past.

The latest vitalist conceptions are based not on scientific data—which serve, rather, to illustrate them—but on philosophical notions (Driesch's entelechy, for example, and so forth). The notion of a special vital energy (W. Ostwald) is likewise more connected with philosophical, than with scientific data. Facts have failed to confirm its actual existence.

The provenance of the energy of living matter (Section 7) is beyond any doubt. It is completely confirmed by quantitative, experimental calculations.

17 Likewise, there is no need to discuss chemical composition. There are no special, life-bearing, biogenic chemical elements, as was still thought quite recently (Section 15, XIV).

The possibility is not excluded, incidentally, that chemical elements may have a different atomic weight, but then analogous changes should occur also in inert natural bodies outside the biosphere (and, perhaps, sometimes within it?). All of these phenomena require systematic scientific study.

Beyond a doubt, the overwhelming majority of biochemically formed molecules sharply differ, from the chemical compounds of inert natural bodies. In the latter, such molecules do not form. Thanks to biogenic migration, however, they do form in the geochemical cycles of the biosphere, where atoms freely move from living bodies to inert ones, and back again. The reaction takes place by utilization of

the same energy.

The possibility must be considered, of delays in the biogenic migration of chemical elements, in the event their atomic weight changes (Section 15, XIV). This will be decided by experiment and observation in the near future.

18 But, for space-time, matters are more complex. On the one hand, we enter here into a domain that has not yet been investigated scientifically; and, on the other, we address that substrate of all natural processes (their geometry), which the naturalist is accustomed to leaving aside, unexamined, in his scientific work.

This substrate—the geometrical state of physical space—lies deeper than all physico-chemical processes. But, I think, it is even more real than they are.

At present, the reigning notion—sometimes wrongly posited as an axiom—is that one and the same geometry is manifested in all terrestrial phenomena. But the naturalist cannot construct his conceptions on the basis of axioms, not even logical axioms, because their axiomatic character cannot be demonstrated except by scientific experiment, experience, and observation. Logic is always less comprehensive than Nature (the biosphere, in this case), since logic corresponds to an abstraction, i.e. a simplified picture of Nature.

In considering the *possibility* of the simultaneous occurrence of different geometries on our planet, we must verify their existence experimentally. If the naturalist comes upon phenomena, which permit him to check this by experiment and observation, he is obliged to do so.

Before our present century, only three-dimensional Euclidean geometry was considered in scientifically studied phenomena. In the new scientific-philosophical conceptions, connected with Einstein's constructions, four-dimensional space is considered; this space corresponds, in the opinion of some, to a Riemannian, rather than a Euclidean space. Theoretical physics is rightly searching for new pathways here, but it has not carried its analysis through to the end, as logic demands.

19 Before going further, it is indispensable to clarify, to what extent it is possible, in our scientific reality, to admit the simultaneous manifestation of *spaces, characterized by different geometries*, in different domains.

It seems to me, that people today assume that such a thing is impossible, without submitting the question to analysis. We can see this from the history of geometry. In his time, Lobachevsky allowed the possibility, that the structure of the space of scientific reality was defined by a new geometry, which he had discovered, rather than by Euclidean geometry. He tried to arrive at an experimental test of this conclusion, by taking a real measurement of the largest star triangles in the heavens. At the present time, Eddington is trying to detect a true four-dimensional

space—one of the Riemannian spaces—corresponding to Einstein's conception of the Cosmos.

But all of this is only the simplest, most abstract conception of the Cosmos, which might satisfy the geometer and the theoretical physicist, but which contradicts the entire empirical knowledge of the naturalist.

Another conception is logically possible—the conception of *the geometrical inhomogeneity of reality*. It is closer to precise empirical knowledge, without contradicting what we know scientifically: *It is the supposition, that, in different cases and different manifestations of the Cosmos, different geometries may be manifested in phenomena under scientific study.*

The hypothesis of a single unified geometry for the Cosmos as a whole, for the entirety of reality, is inseparably connected with the hypothesis, that the propositions of geometry originate as special properties of our reason. The history of geometry refutes this.

20 This leads me to the following considerations. We know now, that there can be a whole array of geometries, and that they may be divided into three types—Euclidean, Lobachevskian, and Riemannian—,and that all of them are irreproachable and equally true. At present, the work of generalization is proceeding successfully, to bring them all into a *single generalized geometry*.

But at the present moment, the history of science clearly demonstrates that geometry and its laws, with respect to their fundamental basis, are adduced in empirical fashion, like all other scientific generalizations of the properties of matter and energy. The foundation, from which these laws are derived in deductive fashion, is the precise scientific observation and experience of the thinker. In science today, one can hardly proceed from other philosophical and unscientific notions about the genesis of the laws of geometry, as a starting point, and then see in them a logical manifestation of human reason. I always prefer, wherever it is scientifically permissible, not to depart from an empirical scientific basis.

Starting from such a basis, one can, if necessary, allow that reality is geometrically inhomogeneous, that different geometries may be manifested in different phenomena, and that we must take this into account in our scientific work. *In the biosphere we confront this sort of geometrical heterogeneity.*

21 For us, space is inseparable from time. This conception is not a consequence of the theoretical propositions of Einstein, but was obtained independently of them and much earlier. I have tried to show this in another location.

We are presently living through an extremely important epoch in the development of science. For the first time, the object of scientific investigation is *time*, which for centuries remained outside its scope. This circumstance characterizes the science of our time and distinguishes it from the science of the 19th century. It is now becoming clear, that time is an extremely complex manifestation of reality, and that the con-

tent of this concept is extremely rich.

Speaking about space-time, we merely indicate the inseparability of one from the other. *For science there is no space without energy and matter, nor, in exactly the same sense, without time.* The conception of Minkowski and his predecessors, about time as a fourth dimension of space, is a mathematical abstraction having no logical grounding in scientific reality; it is a fiction, which does not correspond to the real content of science, nor to a true scientific conception of time. Time is not a dimension of metric geometry. Of course, time can be expressed in geometry by a vector, but it is obvious that such a representation of time does not subsume all of its properties in the natural phenomena studied by the naturalist; it provides him nothing real by way of knowledge. He has no use for it.

Twentieth-century science is now at a stage, when *the moment has arrived to study time, in the same way as we study the energy and matter filling space.* Minkowski's time, considered as the fourth dimension of Euclidean space, does not correspond to the time, which is actually observed in physical space. We should not forget, that in concrete scientific work, we, generally speaking, are not dealing with the abstract absolute space of geometry. At every step, we are dealing with the much more complex *real space of Nature*.

In a vacuum and very often in gaseous media we can extremely often, without need of corrections, use all the conclusions that follow from the properties of the abstract space of Euclidean geometry. But, not always. Already in most of the problems we face, involving fluids and solid bodies, we cannot do this. In connection with this, it is convenient, as we shall see, to distinguish the real space of Nature—in this case the biosphere—as a *physical space*, from geometrical space; in the manner, that Helmholtz apparently, first proposed to do.

In exactly the same way, the naturalist's *time* is not the geometrical time of Minkowski, is not the time of mechanics and theoretical physics, or chemistry, and is not the time of Galileo or Newton.

In Section 15, I indicated the sharp empirical distinction of time for living and inert natural bodies of the biosphere. In living natural bodies it is manifested in the *succession of generations*—a phenomenon, which is absolutely absent in inert bodies.

The succession of generations is the characteristic biological manifestation of time, sharply distinguishing one form of living matter from another, with different scales of comparison for each. It is also possible to find a common scale for all of these.

22 Proceeding from everything said above, it is convenient for purposes of organizing scientific work, to take as a scientific working hypothesis, that the space inside a living organism is different from the space inside inert natural bodies of the biosphere; that this space does not correspond to a special state of living matter within the bounds of Euclidean geometry, and that time is expressed in this space by a polar vector. The existence of right- and left-handedness, and their physico-chemical non-equiva-



NASA

Vernadsky's concept of the noosphere envisioned the extension of the human mind over the Earth and into space. Here, Astronaut Bruce McCandless walks in space, during a Shuttle mission.

lence, point to a different geometry than Euclidean—the geometry of space inside living matter.

From my discussions with geometers, it has become clear to me that the geometry, corresponding to the required conditions, has not yet been elaborated. According to indications by Academician N.N. Luzin and Professor S. P. Finikov, it is possible, that it is one of the geometries of the Riemannian type; perhaps one of those pointed to, but not elaborated, by Cartan. This geometry reduces all space to a point, endowed with the germ of a vector.

It were desirable, that these questions attract the attention of geometers. The investigative work of naturalists, in reality, always employs the mathematical constructions of geometers. Without them, it cannot develop correctly. On the other hand, mathematical thinking grows and discovers its new domains, when scientific thought or the life around us confronts it with new problems. *The geometrical character of the space, occupied by the living matter of the biosphere*, is such a new problem. Characteristic for that space are polar vectors (i.e. the absence both of a center of symmetry and of complex symmetry); the non-equivalence of right- and left-handedness (their failure to appear in combination or appearance in only partial combination); the marked chemical non-identity of right- and left-handed phe-

nomena and compounds, and atomic structures (molecules and monocrystals). Characteristic is the conspicuous absence, in living organisms, of plane surfaces and straight lines; the symmetry of living organisms is distinguished by the curved lines and curved surfaces, characteristic of Riemannian geometries. One more identifying mark, which is usual for Riemannian geometries, is a finite and closed space, sharply distinguished from its surroundings, and autonomous. This is completely coherent with the character of aloofness of living organisms in the biosphere, their autarchy.

Which of the array of Riemannian geometries is appropriate here? What are its geometrical characteristics? It seems to me, that this task cannot be ignored by our geometers. It deserves their attention in and of itself as a geometrical problem.

All the more so, because it is connected with a still more general physical problem: with the question of the geometrical states of *physical space*, which have been very little touched upon by philosophical and physical thought.

In the next article I shall try to present a concept of this problem.

I consider it a pleasant duty to express my gratitude to N.N. Luzin and S.P. Finikov, who helped me with valuable suggestions in the course of our conversations.

—Uzkoye, June 1938

Notes

1. Vernadskii, V. *Problemy biogeokhimii. I. Znachenie biogeokhimii dlia poznaniia biosfery*. [Problems of Biogeochemistry. I. The importance of biogeochemistry for cognition of the biosphere.] 2nd ed. (1st ed.—1934). Leningrad, 1935.
2. Le Roy, E. *L'exigence idéaliste et le fait d'évolution*, Paris, 1927, p. 196.
3. Vernadskii, V. *Biosfera*. Leningrad, 1926. Vernadskii, V., Tr. *Biogeokhim. labor.* [Works of the Biogeochemical Laboratory]. 1. Leningrad, 1930. Vernadsky, W. *La biosphère*. Paris, 1930. Vernadskii, V. *Biogeokhimicheskie ocherki*. Moscow, 1939 (in the process of publication [Vernadsky's note]).
4. Vernadskii, V. *O predelakh biosfery. Izvestiia AN SSSR. Seriya geol.* [Concerning the boundaries of the biosphere. News of the Academy of Sciences of the U.S.S.R. Geology Series], 1937.
5. Vernadskii, V. *Biosfera*. Leningrad, 1926; *Ocherki geokhimii* [Sketches on Geochemistry]. 2nd ed. Leningrad, 1934 (first published in French in 1924, as *La géochimie*); *Problemy biogeokhimii. I.* [Problems of Biogeochemistry. I.] 2nd ed., Leningrad, 1934.
6. Vernadskii, V. *Ocherki geokhimii* [Sketches on Geochemistry]. Leningrad, 1934; *Biogeokhimicheskie ocherki* [Biogeochemical Sketches]. Moscow, 1939 (in the process of publication).
7. Vernadskii, V. *Ocherki i Rechi* [Sketches and Speeches]. Prague, 1922, p. 77. *Problemy biogeokhimii. I.* [Problems of Biogeochemistry. I.] Leningrad, 1934.
8. I have to introduce a *new word* for this old concept, although the enormous significance of the concept it embraces is clear to everyone, as is the exclusive importance of work on the scientific apparatus, in terms of both the time and the labor, spent on it by scientific researchers. This is a consequence of vestiges of the past, of a time when work in philosophy—rightly so, at that time—was considered more fundamental than scientific work.
9. Samoilov, Ia. *Biolity* [Bioliths]. Moscow, 1929.
10. On Redi's principle, see Vernadskii, V. *Ocherki geokhimii* [Sketches on Geochemistry], 4th ed., Leningrad, 1934, p. 209.
11. For viruses, it is still unclear whether we are dealing with a new form of organism ("living protein"), or with a protein, which contains the spores of miniscule organisms. It is thought that *the proteins cannot be cleansed of these spores by crystallization*.
12. Vernadskii, V. *Problemy biogeokhimii* [Problems of Biogeochemistry]. Leningrad, 1935. Vol. 1., 8 f.