

# 21<sup>st</sup> CENTURY SCIENCE & TECHNOLOGY

WINTER 1995-1996

\$3.50/IN CANADA \$4.50

THE DARWIN  
DEBATE  
P. 10

## Riemann Refutes Euler

Suppressed Writings  
On Epistemology,  
Gravitation  
And Light

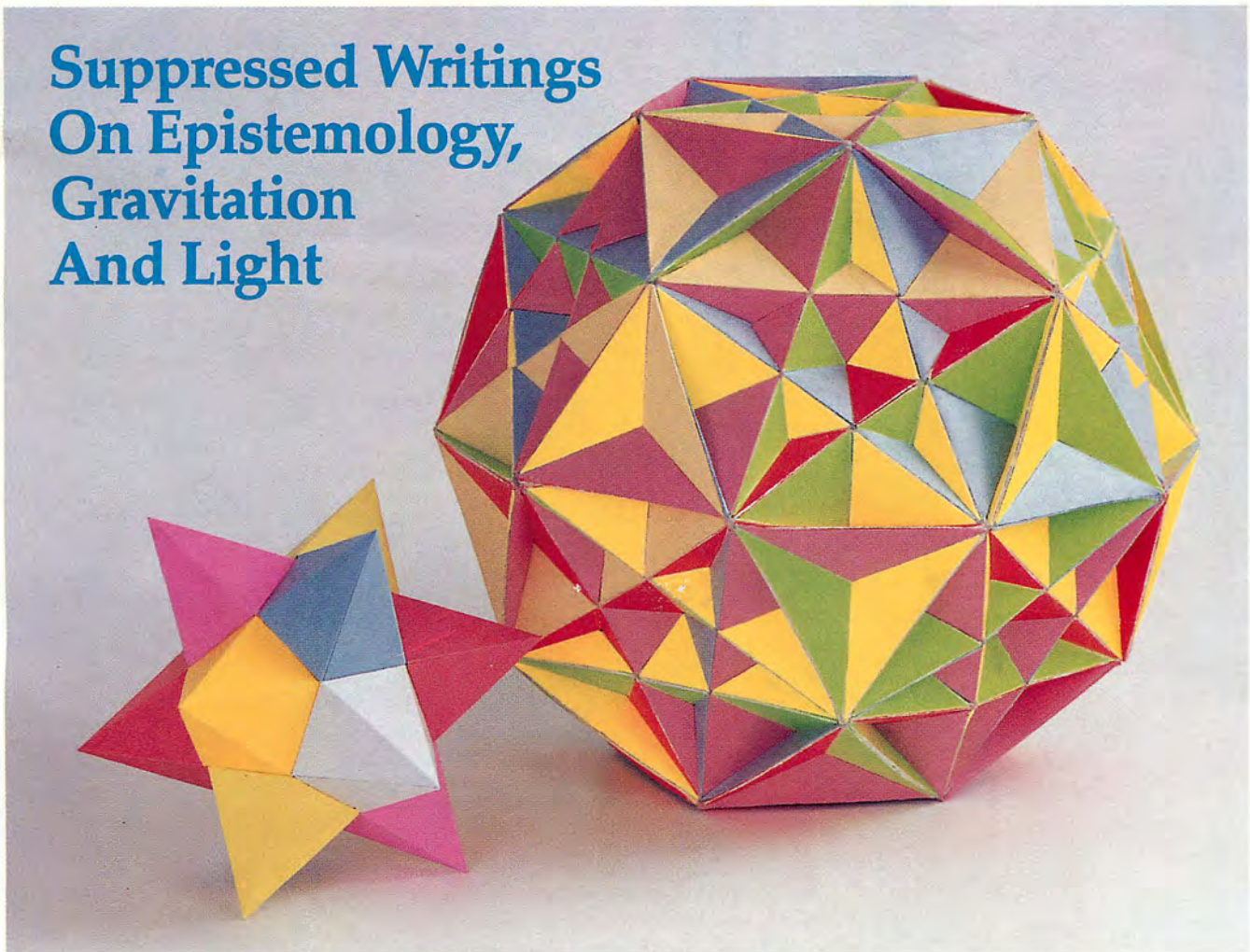

- 400th Anniversary of Kepler's *Mysterium Cosmographicum*
- Celebrate Kepler by Building His Polyhedra!





# Introduce **21<sup>st</sup> CENTURY** SCIENCE & TECHNOLOGY

## to your family and friends



### Subscriptions:

U.S.—6 issues for \$25  
Foreign—6 issues for \$50

### Books

*The Holes in the Ozone Scare:  
The Scientific Evidence*

*That the Sky Isn't Falling*

by Rogelio A. Maduro and  
Ralf Schauerhammer

\$15 each, plus \$3 shipping OR \$10  
postpaid with a subscription

*How We Got to the Moon:*

*The Story of the German Space Pioneers*

by Marsha Freeman

\$15 each, plus \$3 shipping OR \$10  
postpaid with a subscription

*Global Warming:*

*The Rest of the Story*

by Dr. Gerd Weber

\$11 each, postpaid OR \$8 postpaid  
with a subscription

*Hermann Oberth:*

*The Father of Space Flight*

by Boris V. Rauschenbach

\$15 each, plus \$3 shipping OR \$12  
postpaid with a subscription

*Video on the ozone hoax*

"Fair Skin—Stay In"

1-hour documentary produced by the  
Belgian television network BRTN. VHS,  
English narration, some subtitles.

\$20 each, plus \$3 shipping

**Special offer:** Get a subscription to  
*21st Century Science & Technology*  
magazine and save up to  
\$8 per book!

### Give 21st Century subscriptions and gifts

#### ORDER FORM

Enclosed is \$ \_\_\_\_\_ for:

\_\_\_\_ 6 issues/ U.S.—\$25

\_\_\_\_ 12 issues/ U.S.—\$48

\_\_\_\_ 6 issues/ foreign airmail—\$50

\_\_\_\_ 12 issues/ foreign—\$98

\_\_\_\_ \$10 for *The Holes in the Ozone Scare* with a subscription

\_\_\_\_ \$18 postpaid for *The Holes in the Ozone Scare*

\_\_\_\_ \$10 for *How We Got to the Moon* with a subscription

\_\_\_\_ \$18 postpaid for *How We Got to the Moon*

\_\_\_\_ \$8 for *Global Warming* with a subscription

\_\_\_\_ \$11 postpaid for *Global Warming*

\_\_\_\_ \$12 for *Hermann Oberth* with a subscription

\_\_\_\_ \$18 postpaid for *Hermann Oberth*

\_\_\_\_ \$23 postpaid for ozone video

Please print or type name and address of gift recipients on a separate paper. Gift cards are available.

Note: Back issues are available at \$5 each (\$6 foreign)

Name \_\_\_\_\_

Address \_\_\_\_\_

City \_\_\_\_\_ State \_\_\_\_\_ Zip \_\_\_\_\_

Daytime telephone ( \_\_\_\_\_ ) \_\_\_\_\_

Send check or money order (U.S. currency only) to:

*21st Century*, P.O. Box 16285, Washington, D.C. 20041.

# 21<sup>st</sup> CENTURY SCIENCE & TECHNOLOGY

Vol. 8, No. 4

Winter 1995-1996

## Features

- 22 **Johannes Kepler's *Mysterium Cosmographicum***  
**A Guide to the Harmony of the Mind and the Universe**  
*Ralf Schauerhammer*  
Four hundred years later, Kepler's first work still tells us more about the solar system and human creativity than Newton or any other empiricist is capable of doing.

- 35 **First English Translation:**  
**RIEMANN'S PHILOSOPHICAL FRAGMENTS**

FOREWORD

- 36 **Riemann Refutes Euler**

*Lyndon H. LaRouche, Jr.*

TRANSLATION

- 50 **Philosophical Fragments**

*Bernhard Riemann*

- 50 Introduction to Second German Edition  
50 Translator's Note  
51 I. On Psychology and Metaphysics  
55 II. Epistemological Issues  
57 III. Natural Philosophy

SUPPLEMENTARY MATERIAL

- 44 **On the Hypotheses Which Lie at  
The Foundations of Geometry [excerpts]**

*Bernhard Riemann*

- 47 **Riemann in English Translation**  
48 **Euler's Lying Attack on Leibniz**  
52 **Herbart on the Thought Process**

## News

- SPECIAL REPORT: THE DARWIN DEBATE**  
10 In Defense of Darwin  
11 Bury Darwin—It's Overdue!  
**FUSION REPORT**  
63 Tokamak Plasma Advances Made  
But Budget Cuts Threaten Program  
**GEOMETRY**  
66 In the Footsteps of Kepler:  
A Master Polyhedra Builder Demonstrates His Art

## Departments

- 2 EDITORIAL  
4 LETTERS  
5 VIEWPOINT  
The Infamous  
Delaney Clause  
8 NEWS BRIEFS  
69 BOOKS

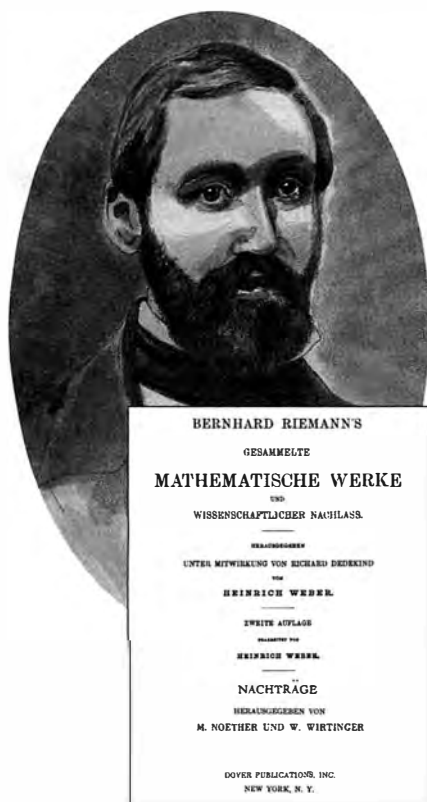

*Bernhard Riemann (1826-1866), with title page from the second German edition of his works.*

**On the cover:** Two polyhedra built by Father Magnus Wenninger: The larger model is a perfect polyhedron with the vertices of the Archimedean icosadodecahedron, which has 30 rectangular faces and 20 perfect hexagons. With it is a small stellated dodecahedron. Philip Ulanowsky photographed the models; cover design is by Rosemary Moak.



#### EDITORIAL STAFF

**Editor-in-Chief**  
Carol White

**Managing Editor**  
Marjorie Mazel Hecht

**Associate Editors**  
David Cherry  
Marsha Freeman  
Laurence Hecht  
Carol Hugunin  
Rogelio A. Maduro  
Jim Olson  
Charles B. Steyens  
Mark Wilsey

**Books**  
David Cherry

**Art Director**  
Rosemary Moak

**Advertising Manager**  
Marsha Freeman

#### SCIENTIFIC ADVISORY BOARD

Francesco Celani, PhD  
Hugh W. Ellsaesser, PhD  
Bertha Farfán, MD  
James Frazer, PhD  
Emmanuel Grenier  
Wilford Hansen, PhD  
Hideo Ikegami, PhD  
Lyndon H. LaRouche, Jr.  
Wolfgang Lillge, MD  
Ramtanu Maitra  
Giuliano Preparata, PhD  
B.A. Soldano, PhD  
B.P. Sonnerblick, PhD  
Jonathan Tennenbaum, PhD  
Daniel R. Wells, PhD

*21st Century Science & Technology* (ISSN 0895-6820) is published 4 times a year in 1995, every third month, by 21st Century Science Associates, 60 Sycolin Road, Suite 203, Leesburg, Va. 22075. Tel. (703) 777-7473.

Address all correspondence to *21st Century*, P.O. Box 16285, Washington, D.C. 20041.

Second-class postage is paid at Leesburg, Va. and additional mailing offices.

Dedicated to providing accurate and comprehensive information on advanced technologies and science policy, *21st Century* is committed to restoring American scientific and technological leadership. *21st Century* covers the frontiers of science, focusing on the self-developing qualities of the physical universe in such areas as plasma physics—the basis for fusion power—as well as biology and microphysics, and including groundbreaking studies of the historical development of science and technology. Opinions expressed in articles are not necessarily those of 21st Century Science Associates or the scientific advisory board.

Subscriptions by mail are \$25 for 6 issues or \$48 for 12 issues in the USA and Canada. Airmail subscriptions to other countries are \$50 for 6 issues. Back issues are \$5 each (\$6 foreign). Payments must be in U.S. currency.

POSTMASTER: Send address changes to 21st Century, P.O. Box 16285, Washington, D.C. 20041-0285.

Copyright © 1995  
21st Century Science Associates

Printed in the USA ISSN 0895-6820

## EDITORIAL

# The Kepler Year

Science today is under very brutal attack. The pay-as-you-go idea that all research must have an immediate, practical goal means the death of fundamental science. Then there are the myriad environmentalist frauds promoted in the name of science. Indeed, young people today are taught pagan ideology—a resurrection of the cult of the earth goddess Gaia—as science. If these trends continue, scientific inquiry will soon be a thing of the past, and we will have doomed ourselves and our posterity to a misery and banality still unimagined today.

Things were certainly better in the United States of John F. Kennedy, but it would be wrong to look for simple answers to the question of how we got from there to here. One reason for the institutional destruction of American science today lies in the increasing bureaucratization of science since World

War II, but that is certainly not the root cause of the problem. Nor even are the openly Malthusian goals of the environmentalists at the root.

We could not have come to this pass were there not a far graver problem, exemplified by the sterile orthodoxy of modern mathematical physics. Nature is expected to conform to a preconceived, axiomatically closed mathematical theorem structure, according to the precepts of Aristotelian logic.

At *21st Century*, therefore, while we deplore the present crisis in science, we see it as an opportunity to get rid of the dead weight of the past, in order to allow the birth of a new scientific renaissance, based upon the principles of creative discovery. We commit ourselves to this, in the spirit of Johannes Kepler, who 400 years ago, in 1596, published his first major work, *The Secret of the Universe*.

# Those Impossible Waves In the Solar Wind

In July, three AT&T Bell Labs scientists reported their discovery that the solar wind—the flow of plasma from the Sun—carries waves that originate in the vast number of vibrations or oscillations of the Sun itself. What is apparently happening is that the densities of the various particles thrown off by the Sun have stable variations with time. That is, they have a wave structure, and it continues out into the solar wind.

This is not supposed to be possible, as can be seen in the comments of other scientists reported below. According to the textbooks, the upper atmosphere of the Sun is so inhomogeneous that the neat patterns of the solar oscillations would be disrupted and not carried out into the solar wind. Moreover, the solar wind itself is turbulent, and

this should destroy the waves, the textbooks say. Finally, the solar wind eventually becomes so rarefied and collisions so rare, that no wave could continue to propagate.

But they do!

This is good news for solar-terrestrial science precisely because it upsets these fundamental ideas imposed on the field by the Newton-Euler mindset. Indeed, the news continues, as of this writing, to create excitement among specialists, who express "surprise, wonder and skepticism"—in the words of one commentator—even though they have yet to scrutinize those hegemonic, fundamental assumptions that are implicitly being challenged.

Presumably, the key is in the behavior of the interplanetary magnetic field,

but certainly not in particle-particle interactions.

### Some Details

Since this editorial is also the first report of the discovery in *21st Century*, some details are in order here. In "Propagation of Solar Oscillations Through the Interplanetary Medium" (*Nature*, July 13), David Thomson, Carol MacLennan, and Louis Lanzerotti report on their analysis of 1992-1994 data from the *Ulysses* spacecraft, with earlier *Voyager 2* data as a cross-check. They find that the spectra of temporal variations of low-energy hydrogen and helium ion flows coming from the Sun show very sharp, distinct frequencies.

Most of these waves should result from *g* modes in the Sun, according to Thomson et al. These *g* modes are hypothetical standing density waves in the Sun for which gravity is said to be the restoring force, and which are supposed to originate deep within the solar interior. Because waves with the periods predicted for *g* modes have not been independently detected on the Sun with any certainty, such solar *g* modes remain hypothetical.

The three scientists thus could not link the ion waves they have found in the solar wind to phenomena in the Sun at present, and so they pursued a flanking strategy. *p* waves, for which pressure is said to be the restoring force, are abundantly seen on the Sun with optical telescopes by helioseismologists. These *p* waves have periods of 4 to 20 minutes (frequencies of 1,000 to 5,000 microhertz), while the expected periods of *g* waves range from 40 minutes to a few days (frequencies of less than about 400 microhertz). Thomson et al., therefore, sought to find a clear link between these *p* waves and those particles in the solar wind that should be coupled with them. These particles turn out to be energetic electrons.

Would the frequencies of the energetic electrons, as detected by *Ulysses*, be the same as the frequencies of the known *p* modes? Of 118 frequencies between 1,588 and 4,200 microhertz, 90 matched to within 1.2 microhertz. This is the really significant and fascinating finding reported by the three.

Strangely, the electron frequencies

were all systematically higher by a factor of 1.00078. Thomson et al. think the factor of 1.00078 might be a consequence of a Doppler effect. Or, it might be a variation in the solar cycle, since the two data sets were taken at different points in the cycle.

Charged particles from the Sun enter Earth's magnetosphere, where they are best known for damaging spacecraft electronics and inducing voltage surges in telephone and power lines. Now that the particles have been found to be ordered in waves, it would be useful to ask what implications this has for the workings of nature on Earth.

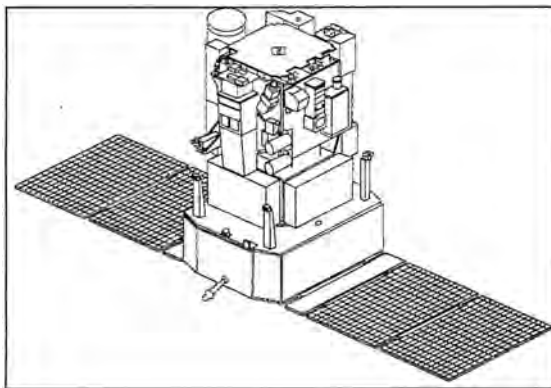

*SOHO, the Solar and Heliospheric Observatory, launched in December, will probe the Sun's oscillations and the solar wind.*

### The Commentators

While these results are exciting because they send the textbook out the window, it is also encouraging to see that scientists recognize that consequence and at least some of them seem to accept it. In a commentary on the findings in the same issue of *Nature*, Douglas Gough of the Institute of Astronomy at Cambridge University writes, "The discovery is amazing in the light of current thinking about the solar wind, because such thinking is based on the idea that the temporal variation is predominantly the consequence of turbulence, which has a relatively smooth spectrum."

Gough also indicates the other side of the same coin in pointing out that "more or less everyone has always assumed that any seismic disturbance propagating through the chromosphere into the corona would be washed out by the substantial inhomogeneities in the upper solar atmosphere."

In the words of Ray Ladbury, writing

in *Physics Today* in September, the results of Thomson et al. "are particularly interesting because they imply that the Sun's core and the solar wind are coupled, although half a billion kilometers of largely turbulent plasma and 24 to 26 orders of magnitude in density separated the solar core from where the satellite measured the solar wind ion flux."

So we have a picture of these waves "lasing" through the inhomogeneities of the upper solar atmosphere and the turbulence of the solar wind. Additionally, the waves continue to propagate even when the solar wind has become so rarefied that, from the standpoint of percussive propagation, they should not.

Ladbury goes further. Confirmation of the results of Thomson and his colleagues, he writes, "would go a long way toward establishing their results as a truly revolutionary contribution to space physics."

Those are well-chosen words: "would go a long way toward. . . ." Because to *fully* establish these results as a revolutionary contribution, the implicit falsification of the Newton-Euler model of percussive causality, in favor of the physics of Kepler, Leibniz and Riemann, would have to be taken

to heart and carried into all related fields, including the study of climate and weather. Lyndon LaRouche's article, "Riemann Refutes Euler" (page 36), speaks to this issue.

### The Next Steps

There may be an early confirmation of the thinking of Thomson et al. with respect to the so-called *g* modes. SOHO, the European Space Agency's Solar and Heliospheric Observatory launched December 2, may be able to detect these solar oscillations that are predicted by the Thomson paper.

SOHO's 12 instruments, together with those of the continuing Wind project, and the new ground-based network of helioseismology telescopes called GONG (Global Oscillation Network Group) promise major discoveries in the ordering of the solar-terrestrial relationship.

However, if the results are to be coherent, the revolution in assumptions referred to above is a necessary complement to the advances in technology.

## Letters



### Nobel Extrapolators?

*This letter was sent to Chemical & Engineering News in response to its Oct. 9, 1995, editorial attacking those who questioned the ozone depletion "consensus." It is printed here with permission of its author, Hugh W. Ellsaesser, Ph.D., who is a participating guest scientist at the Global Climate Research Division of Lawrence Livermore National Laboratory. Ellsaesser's article, "A Rational View on Stratospheric Ozone: The Unheard Arguments," appeared in the Fall 1994 issue of 21st Century.*

#### To the Editor [of C&E News]:

In response to your editorial of Oct. 9, may I present a few facts about stratospheric ozone.

The original Rowland/Molina theory predicted the major destruction of ozone by chlorine would be at about 40 km. Observations show some decline there but generally less than that predicted; this is described as "broad agreement."

Formation of the Antarctic ozone hole, which occurs between 12 and 22 km, was not predicted.

Observations "show that much of the downward trend in ozone occurs below 25 km"; therefore, this also was not predicted.

Models including the chemistry involving sulfate aerosol and polar stratospheric clouds "still underestimate the ozone loss by factors ranging from 1.3 to 3."

As NASA's Dr. Robert Watson, organizer and director of the Ozone Trends Panel, told *Science*, "[our ozone] models do not predict that ozone decreased the way it did over the Northern Hemisphere during the past 17 years" (*Science*, Vol. 239, p. 1489, 1988).

As Harvard's Professor Jim Anderson told *The New York Times Magazine*: "The thinning of the ozone layer over other parts of the Earth is accelerating, and we don't know why, and we don't know how fast. We don't know what

factors control the movement of ozone in the stratosphere. We don't know what part of the thinning is due to natural dynamics of the atmosphere and what part is due to the destruction of ozone by man-made chemicals. We don't know much of anything. . . . We've confused computer models of the atmosphere with the real thing. We're making huge extrapolations based on nothing but models, and models are often wrong" (*The New York Times Magazine*, March 13, 1994, pp. 36-39).

I have a question. On what criterion was the Nobel Prize awarded to Crutzen, Molina, and Rowland?

(All quotes without attribution are from the Executive Summary of the World Meteorological Organization's *Scientific Assessment of Ozone Depletion*, 1994.)

Hugh W. Ellsaesser  
Livermore, California

### EUREKA! It's Not Euclid

#### To the Editor:

The handsome cover of your Fall 1995 issue, headlined "Eureka! Rediscovering the Method of Archimedes," shows a large detail of the right-hand side of Raphael's famous fresco of 1509, usually called "The School of Athens." Some readers who are familiar with the work, often reproduced, might be puzzled, however, that the bald man drawing on a slate with a compass, who clearly represents Geometry, is called "Archimedes." This figure, whose garment was signed by Raphael with his own name, is almost always called "Euclid" whenever the picture is published.

The correct identification of this figure is due to Konrad Oberhuber in the 1972 book, *Il cartone per la Scuola d'Atene*, published in Milan by Silvana Editori. Dr. Oberhuber, one of the leading scholars of Renaissance art and especially of Raphael, pointed out that few of the identities of the personages in the painting are known with certainty, apart from the central figures of Plato and Aristotle (not shown in your detail).

According to Oberhuber, the idea that the geometer is Euclid did not appear in print until it was suggested in 1864 by an English writer. However, it is known that during the papacy of Paul III, who reigned 1532-1547, this figure was be-



Nora Hamerman

*Perin del Vaga's 16th-century painting, directly under Archimedes in Raphael's "School of Athens," shows Archimedes drawing as he is about to be killed by a Roman soldier.*

lieved to be Archimedes. This is attested to by the image that Perin del Vaga, a pupil of Raphael, frescoed at that time directly under the geometry group for the "basement"—part of the walls up to the height of the doors, where the original decoration had been destroyed during the Sack of Rome in 1527.

Some years after I first read Oberhuber's explanation, I happened to visit the Stanza della Segnatura in the Vatican Palace where the murals are, and snapped a photo of Perin del Vaga's painting. The subject is unmistakable: It shows the aged Archimedes as he is about to be killed by Roman soldiers in Syracuse, while drawing circles on the ground. [See photo.]

By the way, Archimedes was greatly admired in Platonic circles in Rome in the early 16th century, because he combined mathematical theory with physical applications, particularly in the defense of the state—a timely issue in the turbulent times when Raphael lived. (Archimedes was supposed to have invented the "Greek fire," which the Syracusans used to fight the Romans and other enemies.)

Nora Hamerman  
Leesburg, Virginia

Mrs. Hamerman, an art historian, is senior editor of *Executive Intelligence Review*.

## The Infamous Delaney Clause

One of the primary instruments used by environmentalist groups to attack food producers, food processors, and food consumers has been the Delaney Clause of the Federal Food, Drug, and Cosmetic Act. This year, Congress has an opportunity, in pending legislative bills, to clarify the infamous clause and make its application scientific rather than political.

In 1958, Representative James J. Delaney entered a clause into the food additive provisions of the Federal Food, Drug and Cosmetic Act (21 USCS 348) intended to permit only toxicologically insignificant amounts of additives in the food supply. Both Congress and the Health, Education, and Welfare Department construed the Delaney Clause as specifying that an *insignificant* amount of chemicals, including carcinogens, could be legally permitted in human foods. They did *not* interpret the clause to mean that "zero" amounts of chemicals were required.

Section 408 of the act requires that raw foods or produce conform with tolerance levels established by the Federal Food, Drug, and Cosmetic Act. If the levels are higher than the permitted legal tolerance, the raw food is considered adulterated and cannot be sold.

Section 409 deals with the intentional addition of chemicals to processed foods, as preservatives, dyes, and so on. This section includes the Delaney Clause, which states: "No additive shall be deemed to be safe if it is found to induce cancer when ingested by man or animal, or if it is found, after tests which are appropriate for the evaluation of the safety of food additives, to induce cancer in man or animals."

### Inducing Cancer

The first part of the Delaney Clause ("No additive shall be deemed to be safe if it is found to induce cancer when ingested by man. . . .") is meaningless because it cannot be carried out adequately. Obviously it



by Dr. J. Gordon Edwards

is not possible to experimentally determine human carcinogenicity caused by food unless long-term, strictly regulated tests are carried out. In such tests the activities of a large number of nearly identical, same-sex humans, exposed to the same food, drink, lifestyles, and other factors would have to be monitored and strictly controlled. Very high doses of a single test chemical would have to be given daily to half of the experimental humans, but never to the others (the controls).

Only after months or years of such testing could it be reasonably hypothesized that the high doses of that chemical might have been responsible for cancer formation in the "test humans," but *only* if that type of cancer did *not* also develop in the "control humans" in the experiment. Such tests have never been performed, and obviously never can be performed, on humans in this country; therefore, that part of the Delaney clause is meaningless.

However, the same sentence in the Clause continues with ". . . or if it is found, after tests which are appropriate for the evaluation of the safety of food additives, to induce cancer in man or animals." This might provide a method of actually reaching accurate conclusions, but it is necessary to specify what animal tests are appropriate, and there has never been any broad scientific agreement on that.

Can doses thousands of times greater than those animals ever encounter outside of laboratory cages be considered appropriate for accurately

evaluating cancer risk to humans?

The test animals are routinely fed "maximum tolerated dosages." This means that any increase in the amount of the chemical ingested would rather quickly result in death because of the cessation of normal body functions *unassociated* with carcinogenicity. Also animals ingesting such massive doses often can barely stay alive, and the dosage frequently causes the death of body tissues. As a result, there is a proliferation of new cell divisions, during which numerous mutations naturally occur, and the chances of spontaneous tumors or cancers are also increased. Those mutations are scarce in normal tissues, but occur much more often during abnormally rapid cell proliferation.

Even more important, the data from those experiments cannot be extrapolated to humans living normal lives!

### How the EPA Redefined Cancer

When Rep. Delaney proposed his clause, the prevalent medical definition of cancer was that it was a malignant, invasive growth that expanded rapidly, frequently metastasized (spread to other organs and tissues), and might quickly kill the host. Tumors, on the other hand, were swellings or lumps, some of which might become malignant, but most would not. In experiments, tumors often disappeared completely after the massive overdoses of test chemicals were halted.

In October 1975, attorney Russell Train, the administrator of the EPA, redefined the medical term "cancer," arbitrarily seeking to make "tumor" and "cancer" synonymous. He stated, "For purposes of carcinogenicity testing, no distinction should be made between the induction of tumors diagnosed as benign and the induction of tumors diagnosed as malignant." Under Train,

*J. Gordon Edwards is an emeritus professor of entomology at San Jose State University in California, where he has taught for 46 years.*

## SAVE YOUR COPIES OF 21<sup>st</sup> CENTURY

These custom-made titled cases and binders are ideal to protect your valuable copies from damage. They're designed to hold two years' issues (may vary with issue sizes), constructed with reinforced board and covered with durable leather-like material in blue, title is hot-stamped in gold, cases are V-notched for easy access, binders have special spring mechanism to hold individual rods which easily snap in.



**Cases:** 1—\$7.95 3—\$21.95 6—\$39.95  
**Binders:** 1—\$9.95 3—\$27.95 6—\$52.95

21st Century Science & Technology  
Jesse Jones Industries, Dept. 21C  
499 East Erie Ave., Philadelphia, PA 19134

Enclosed is \$\_\_\_\_\_ for \_\_\_\_\_ Cases;  
\_\_\_\_\_ Binders. Add \$1 per case/binder for  
postage & handling. Outside USA \$2.50 per case/  
binder (US funds only). PA residents add 6% sales  
tax.

Print  
Name \_\_\_\_\_

Address \_\_\_\_\_  
No P.O. Box Numbers Please

City \_\_\_\_\_

State/Zip \_\_\_\_\_

CHARGE ORDERS (Minimum \$15): Am Ex, Visa,  
MC, DC accepted. Send card name, #, Exp. date.  
CALL TOLL FREE 7 days, 24 hours  
1-800-825-6690

**SATISFACTION GUARANTEED**

## Coming in

### 21<sup>st</sup> CENTURY SCIENCE & TECHNOLOGY

- The Fraud in Modern Physics
- What the Suppressed Works of Gauss and Weber Reveal
- Kepler in China
- Ancient Chinese Astronomy
- Climate Models Model Ideology
- Environmentalism's Disease Death Toll
- The Herschels' Revolution in Astronomy



"The court finds you guilty as charged under the Delaney clause, and sentences you to banishment from the shelves!"

the EPA could consider harmless tumors as cancers and thus subject to the provisions of the Delaney Clause.

Scientists disagreed with this change. For example, the Council for Agricultural Science and Technology, a consortium of more than 30 scientific organizations, observed in its study of the Delaney Clause, "Classifying as carcinogens all chemicals that cause tumors . . . greatly overestimates the 'cancer' risk."

Further criticism came from other scientific groups and even from the EPA's own researchers. The American Council on Science and Health reported in 1991 that "sound toxicological principles are routinely flouted in lab rodent tests on behalf of government agencies, and the results are frequently inappropriately extrapolated to humans." Toxicologists affiliated with the council also pointed out that "a rat is not simply a small human." The two species are physiologically very different; thus they react differently to chemicals.

Rats, for example, which have been the most common test animals, produce a special protein (Alpha 2U Globulin) that makes them especially prone to develop tumors and cancers. In 1991, the EPA pointed out that humans lack this protein, which in fact "could invalidate thousands of tests of pesticides, preservatives, additives, and other chemicals that have been banned on the basis of producing tumors in rats in laboratories." Those tumors, the EPA spokesmen said, "are a species-specific effect," and "are not relevant to human risks from those chemicals."

It is also troublesome to many scien-

tists that most of the rats used in such experiments have been deliberately reared as cancer-prone strains, which develop cancer extremely easily.

Obviously, such tests are not "appropriate for the evaluation of the safety of food additives to induce cancer in man or animals," as required by the Delaney Clause. Representative Delaney later stated that "too many egos, reputations, and careers are at stake; if you try to change things, the crazies just come at you with blowtorches and chain saws." Russell Train, who later became the head of the World Wildlife Fund, knew the consequences of his redefinition of cancer, and made no effort to hide his conviction that pesticides should be banned.

### Natural Pesticides

As analytical techniques became more sophisticated, making it possible to detect smaller and smaller levels of chemicals, scientists had an additional reason to worry about the potential for misapplication of the Delaney Clause. Charles C. Edwards, commissioner of the Food and Drug Administration in 1972, said, "An all-or-nothing law (like the Delaney Clause) should be more flexible, allowing safe levels for use of additives in human food." He also stated, "It is now possible to detect very tiny amounts; thus the Delaney Clause could be interpreted to require banning animal and plant products containing *natural* carcinogens, and a strict interpretation could even require banning certain essential human nutrients."

Some chemicals, such as selenium and Vitamin A, are *anticarcinogenic* at low levels, but may become *carcinogenic* at higher levels, indicating that there are definite thresholds involved. (A threshold is the dose of a chemical below which effects do not result.) "Carried to its logical extreme," warned Edwards, "the Delaney Clause would ban all food containing such carcinogenic environmental contaminants as traces of radioactive material," which all living things naturally contain.

The issue of natural pesticides is not trivial. Dr. Bruce Ames, head of the Biochemistry Department at the University of California, pointed out in



## THE DELANEY CLAUSE



1987 that "we are ingesting in our diet at least 10,000 times more, by weight, of natural pesticides than of man-made pesticide residues." Ames also noted that edible plants often contain natural pesticides making up 5 to 10 percent of the plant's total dry weight, and that many of those tested proved to be carcinogenic.

It is a fact that an abundance of naturally occurring carcinogens is present in most foods, including meat, potatoes, berries, and fruit. They also abound in the liquids we drink. How should we consider the thousands of *natural* carcinogens that have been added by the plants we eat? Those toxins protect the plants from their enemies but are *not* food for the animals that eat them.

In food for human beings, these same chemicals may qualify as environmental hazards. Should these natural environmental hazards, nearly half of which are potential carcinogens, be subject to regulation under the Delaney Clause? As a result of biased interpretations of that Clause, food additives have been defined in a manner that (1) includes many harmless synthetic chemicals that are legally present in meat, vegetables, fruits, and libations, but (2) does *not* include the naturally occurring environmental toxins or carcinogens that are added by the plants we eat!

### From Bad to Worse

In a 1980 policy statement, the U.S. Occupational Safety and Health Agency (OSHA) specified that "negative results in carcinogenicity bioassays simply define a limit beyond which

carcinogenic activity *would have been detected* if higher doses had been applied" (emphasis added). OSHA also stated that "an assay that is *not* positive for carcinogenicity is the same as if the chemical has never been tested for carcinogenicity." Relying on these interpretations, OSHA

could condemn *any* chemical it wished to attack, again using the Delaney Clause as a weapon.

In 1988, the EPA sought to make the Delaney Clause more reasonable by permitting insignificant, harmless amounts of pesticide residues in processed foods. (This is referred to as the *de minimis* standard.) Environmental extremists, bent on removing *all* pesticide traces from food products, challenged that interpretation. In 1992, the environmentalists, supported by the 9th Circuit Court of Appeals in San Francisco, destroyed the EPA's efforts to proceed rationally. Evidently the members of that court had again neglected to read the Delaney Clause or to review the findings of medical scientists and toxicologists!

The U.S. Supreme Court declined to hear appeals by scientific and agricultural groups in this case. Perhaps the Supreme Court intended to force Congress to accurately define "cancer," to specify what laboratory tests for carcinogenicity will be considered appropriate, and to acknowledge the lack of validity of extrapolations from mega-dosed, cancer-prone laboratory rats to humans who ingest concentrations of chemicals thousands of times lower than the doses fed to the rats.

Such congressional actions might result in the demise of the Delaney Clause and the establishment of human food safety guidelines based on science rather than politics. Representative Delaney was unfortunately correct when he said that he would probably go to his grave "with that damned thing hanging around my neck!"

UNITED STATES POSTAL SERVICE Statement of Ownership, Management, and Circulation (Required by 39 U.S.C. 3685)

Publication Title: 21st Century Science & Technology  
 Issue Date: October 1, 1995  
 Frequency: Four Times a Year  
 Annual Subscription Price: \$18.75  
 Complete Mailing Address of Headquarters or General Business Office of Publisher: PO Box 16285, Washington, DC 20041  
 Complete Mailing Address of Principal Office of Publisher: PO Box 16285, Washington, DC 20041  
 Complete Mailing Address of Headquarters or General Business Office of Publisher (if not the same as above): PO Box 16285, Washington, DC 20041  
 Complete Mailing Address of Principal Office of Publisher (if not the same as above): PO Box 16285, Washington, DC 20041

Publication Title	1995	1994
21st Century Science & Technology	27,000	26,000
1. Total No. Copies (Net Press Run)	27,000	26,000
2. Total No. Copies (Net Press Run)	27,000	26,000
3. Total No. Copies (Net Press Run)	27,000	26,000
4. Total No. Copies (Net Press Run)	27,000	26,000
5. Total No. Copies (Net Press Run)	27,000	26,000
6. Total No. Copies (Net Press Run)	27,000	26,000
7. Total No. Copies (Net Press Run)	27,000	26,000
8. Total No. Copies (Net Press Run)	27,000	26,000
9. Total No. Copies (Net Press Run)	27,000	26,000
10. Total No. Copies (Net Press Run)	27,000	26,000
11. Total No. Copies (Net Press Run)	27,000	26,000
12. Total No. Copies (Net Press Run)	27,000	26,000
13. Total No. Copies (Net Press Run)	27,000	26,000
14. Total No. Copies (Net Press Run)	27,000	26,000
15. Total No. Copies (Net Press Run)	27,000	26,000
16. Total No. Copies (Net Press Run)	27,000	26,000
17. Total No. Copies (Net Press Run)	27,000	26,000
18. Total No. Copies (Net Press Run)	27,000	26,000
19. Total No. Copies (Net Press Run)	27,000	26,000
20. Total No. Copies (Net Press Run)	27,000	26,000
21. Total No. Copies (Net Press Run)	27,000	26,000
22. Total No. Copies (Net Press Run)	27,000	26,000
23. Total No. Copies (Net Press Run)	27,000	26,000
24. Total No. Copies (Net Press Run)	27,000	26,000
25. Total No. Copies (Net Press Run)	27,000	26,000
26. Total No. Copies (Net Press Run)	27,000	26,000
27. Total No. Copies (Net Press Run)	27,000	26,000
28. Total No. Copies (Net Press Run)	27,000	26,000
29. Total No. Copies (Net Press Run)	27,000	26,000
30. Total No. Copies (Net Press Run)	27,000	26,000
31. Total No. Copies (Net Press Run)	27,000	26,000
32. Total No. Copies (Net Press Run)	27,000	26,000
33. Total No. Copies (Net Press Run)	27,000	26,000
34. Total No. Copies (Net Press Run)	27,000	26,000
35. Total No. Copies (Net Press Run)	27,000	26,000
36. Total No. Copies (Net Press Run)	27,000	26,000
37. Total No. Copies (Net Press Run)	27,000	26,000
38. Total No. Copies (Net Press Run)	27,000	26,000
39. Total No. Copies (Net Press Run)	27,000	26,000
40. Total No. Copies (Net Press Run)	27,000	26,000
41. Total No. Copies (Net Press Run)	27,000	26,000
42. Total No. Copies (Net Press Run)	27,000	26,000
43. Total No. Copies (Net Press Run)	27,000	26,000
44. Total No. Copies (Net Press Run)	27,000	26,000
45. Total No. Copies (Net Press Run)	27,000	26,000
46. Total No. Copies (Net Press Run)	27,000	26,000
47. Total No. Copies (Net Press Run)	27,000	26,000
48. Total No. Copies (Net Press Run)	27,000	26,000
49. Total No. Copies (Net Press Run)	27,000	26,000
50. Total No. Copies (Net Press Run)	27,000	26,000



Did you miss something?

Back issues of  
**21st CENTURY**  
 SCIENCE & TECHNOLOGY

are available at \$5 each  
 (\$6 foreign).  
 U.S. currency only.

To receive the index for volumes 1-7, send a self-addressed envelope (9 x 12) with 78¢ postage to:

**21st Century**  
 P.O. Box 16285  
 Washington, D.C. 20041

## NEWS BRIEFS

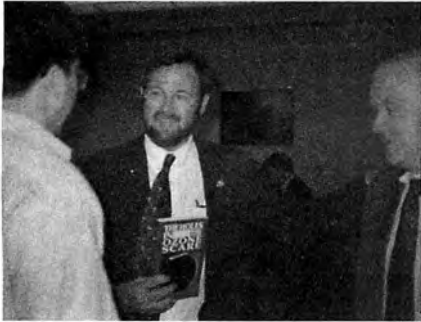

*"The public has been misled, bamboozled, and otherwise manipulated," Dr. S. Fred Singer told Congress. Here, he chats with Rep. Rohrabacher (center) and Rogelio Maduro (left), author of the book The Holes in the Ozone Scare.*

### HOUSE HEARINGS CHALLENGE SCIENCE MAFIA ON OZONE, CLIMATE

Congressional hearings on ozone depletion and on climate models, sponsored by the House Committee on Science's subcommittee on energy and environment, held Sept. 20 and Nov. 16, made it clear that the ban on chlorofluorocarbons (CFCs) is determined by politics, not science; that climate models known to be faulty were used to determine international policy; and that the science establishment is willing to act like a gestapo to prevent scientific dissent on environmental policy.

Subcommittee chairman Dana Rohrabacher (R-Calif.) convened both hearings under the title "Scientific Integrity and Public Trust: The Science Behind Federal Policies and Mandates" and invited both sides of the issues to testify. The ozone hearings were particularly vituperative. The airing of the main scientific arguments against the ozone hoax provoked some congressmen and administration spokesmen to attack those scientists who disagreed with the "consensus" view as "fringe," "irresponsible," and "without standing in the scientific community."

Dr. S. Fred Singer, head of the Science and Environmental Policy Project and an emeritus professor of environmental science at the University of Virginia, and Dr. Sallie Baliunas, an astrophysicist, came under particular fire. Baliunas testified that she had almost pulled out of participating in the hearing that morning because of the ongoing threats to her and her employer. She also told the committee that she was warned not to pursue lines of research that might show the ozone depletion theory to be wrong, because her institution might lose federal and other funding.

Baliunas's testimony is available from the Marshall Institute (202) 296-9655; Singer's testimony is available from SEPP (703) 934-6940.

Hearings in November on the validity of the global climate models were less stormy, but the same arguments were used to maintain that the global warming scenario is correct simply because, allegedly, "the overwhelming majority of scientists" agree that it is.

### GERMAN SPECTROMETER PRODUCES GLOBAL OZONE MAP IN 3-D

A new German spectrometer called *Crista*, deployed on the U.S. Space Shuttle in 1994, has produced the first high precision, 3-dimensional global map of ozone, announced researchers from the University of Wuppertal, who designed the instrument. The ozone layer is a patchwork of large- and small-scale structures and not a uniform longitudinal phenomenon, the researchers said. *Crista's* preliminary results show that the currently accepted ozone models are "junk," they said at a Nov. 6 press conference. More details will appear in the next *21st Century*.

### SPREAD OF UNCONTROLLED EPIDEMICS THREATENS WORLD POPULATION

Top medical experts convened at the 25th anniversary meeting of the National Institute of Medicine painted an alarming picture of emerging and reemerging diseases Oct. 16 at the National Academy of Sciences in Washington, D.C. AIDS, Ebola virus, tuberculosis, bubonic plague, yellow fever, dengue fever, cholera, and diphtheria were among the diseases discussed. The presentations stressed that existing vaccines and antibiotic treatments are failing to deal with these diseases, and that the surveillance networks and laboratories to study the emergence and spread of epidemics and ways to combat them have been dismantled.

Two weeks earlier, the World Health Organization announced the creation of a Division of Emerging Diseases, and a WHO delegation testified on the situation before Congress Oct. 18. "The recent outbreaks have shown that the potential of epidemics is now vastly increased by the speed by which they are able to spread [and] by the unprecedented size, concentration, and mobility of populations," warned a WHO press release.

*21st Century* will report on the situation in the spring issue.

### THE DENGUE EPIDEMIC IN SOUTH AMERICA

Brazil	112,939
Colombia	NA
Ecuador	2,899
Peru	2,059
Venezuela	24,282
Mexico	5,474
Costa Rica	3,324
El Salvador	9,288
Guatemala	2,893
Honduras	13,049
Nicaragua	10,926
Panama	2,116
Puerto Rico	NA
Dominican Republic	1,252
English Caribbean	282
<b>Total</b>	<b>190,554</b>

*Dengue and dengue hemorrhagic fever, a formerly conquered disease, has increased as a direct result of the collapse of mosquito control programs in the past two decades. U.S. health officials are concerned that the epidemic can easily spread here.*

Source: Country reports to the Pan-American Health Organization, Oct. 25, 1995.

### BLUE RIBBON PANEL CALLS FOR BURNING SURPLUS WEAPONS PLUTONIUM

A panel of international experts convened by the American Nuclear Society urged the burning of surplus weapons plutonium as fuel for civilian power reactors in the United States, Russia, and other countries. The blue ribbon panel issued its report on plutonium management in August. Burning plutonium as fuel is the fastest and most effective way of disposing of surplus weapons plutonium, the report says. The panel also recommended that the United States reverse its decision to stop work on reprocessing and on breeding nuclear fuel. "Plutonium is a valuable energy resource, not a waste material to be buried," the report said. In addition, the report said that the developing sector should not have "to forgo the benefits of abundant energy that the industrialized world has enjoyed for many decades" and that there is "no need for international uniformity" in how individual countries configure the nuclear fuel cycle.

The panel was chaired by Dr. Glenn T. Seaborg, who discovered plutonium, and included former government officials, weapons and disarmament specialists, and international nuclear experts. Copies of the report are available at \$20 from the American Nuclear Society in LaGrange Park, Ill., (708) 352-6611.

### CHINESE TO RECONSTRUCT GERMANY'S ASDEX FUSION REACTOR

The German daily *Frankfurter Allgemeine* reported Nov. 29 that a team of Chinese engineers was dismantling the German fusion test reactor ASDEX in Garching, in order to reconstruct it at the South-Western Institute for Plasma Physics in Leshan, Sichuan province, where China is improving its biggest fusion research facility.

### CATOMIC SOCIETY FOUNDED IN JAPAN FOR NUCLEAR CAT LOVERS

Cat lovers who work in the nuclear community now have their own association. As reported in the Nov.-Dec. issue of the *American Nuclear Society News*, the Catatomic Society was formed by Prof. Yoshitsugu Mishima, professor emeritus at the University of Tokyo. Its first meeting in April drew 40 cat lovers, and the group rapidly became international. Membership is \$20 and members receive a pin with the society's logo—a picture of a cat's face within the atomic nucleus. For more information, contact Mishima at the University, 3-30-11 Matsunoki, Suginami-ku, Tokyo.

### ACT OF CONGRESS TO END OBSTRUCTION OF MT. GRAHAM TELESCOPE

Arizona Congressman James Kolbe plans to attach a rider to a suitable federal bill that will clear the way for the University of Arizona to build the Large Binocular Telescope on the best known site. Kolbe hopes to have the rider pass both houses by the Christmas recess. Construction at the telescope site has been halted since July 1994, when a federal District Court granted an injunction to 18 green groups on a technicality, requiring environmental studies for several more years. The rider would void the injunction. Arizona's congressional delegation unanimously supports the rider, and letters and resolutions asking for congressional action have come from towns and counties throughout southeastern Arizona, state legislators from the southern part of the state, the governor, the speaker of the Arizona house of representatives, and president of the state senate, among others. The state's major newspapers are also supporting the telescope in editorials.

### BIOTECHNOLOGY INDUSTRY GROUP LAUNCHES INFORMATION CAMPAIGN

The Biotechnology Industry Organization (BIO) launched a campaign to acquaint the public with the science of biotechnology Sept. 12 at the National Press Club in Washington, D.C. BIO represents 560 biotechnology companies and organizations in 47 states and 20 countries. In addition to releasing a guide for editors and reporters on the major uses of biotechnology, BIO served biogenetically engineered food. For information, contact BIO, (202) 857-0244.

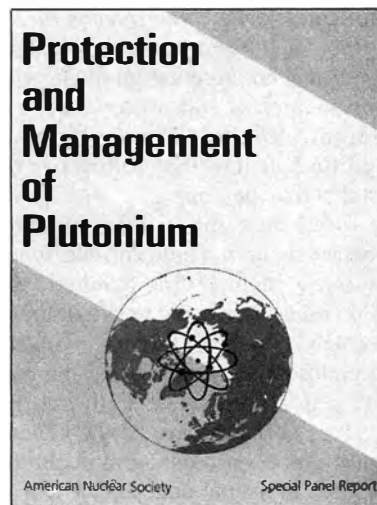

*The ANS report also called for the safe storage of surplus weapons plutonium in the short term under the "strict non-proliferation safeguards" of the International Atomic Energy Agency.*



Stuart Lewis/EIRNS

*Carrots with improved taste, texture, and shelf life; sweet, seedless minipeppers; and pizza made with a genetically modified processing tomato were among the biogenetically engineered products served at the BIO press conference.*



It would be incorrect to establish the scientific paradigms for the 21st century using 18th and 19th century views as the only available data. This anachronous approach, however, is a main line of Carol Hugunin's paper, "It's Time to Bury Darwin and Get On with Real Science." The readers of *21st Century* deserve a more up-to-date, more balanced presentation of Darwin's theory, which is still a cornerstone of modern biology. The critique of Hugunin's article that follows is the least that may be done.

It looks as if the article appeared miraculously from a time capsule, where it lay for a century. One hundred years ago it could have been a state-of-the-art presentation of current topics in science and philosophy. Now it is, for the most part, just a zombie of 19th century dilemmas over Darwin and the German idealist—or even older—pre-evolutionary trends in natural philosophy. The author seems to have missed more than a century that has passed since.

Virtually no current views are presented to support the main thesis, and the reader is left to accept the intuitions of Darwin's contemporaries as if they were ultimate authorities. I, personally, would doubt if the naturalists quoted would still adhere to all of their opinions, were they able to confront them with the current state of paleontology, genetics, evolutionary biology, and so on.

Who knows what von Baer would think, for example, after reading Stephen Jay Gould's books and checking them against the raw data in technical journals? It is just as anachronous to set scientific paradigms for the 21st century using 19th century naturalists as the only experts available, as it is to offer readers a map showing Alexander von Humboldt's route of 1829 into the Soviet Union via Leningrad and Gorki—a trip made decades before Lenin and Maxim Gorki were born and a map printed years after the Soviet Union ceased to exist [p. 35].

The whole article is out of time. I am not inclined to debate with 19th century opinions, as such a belated refutation would be unfair to the long-dead opponents. Many of their views were both novel and scientific at their time. Most of the paper is an interesting historical sketch of the development of 19th century natural sciences, rather than an

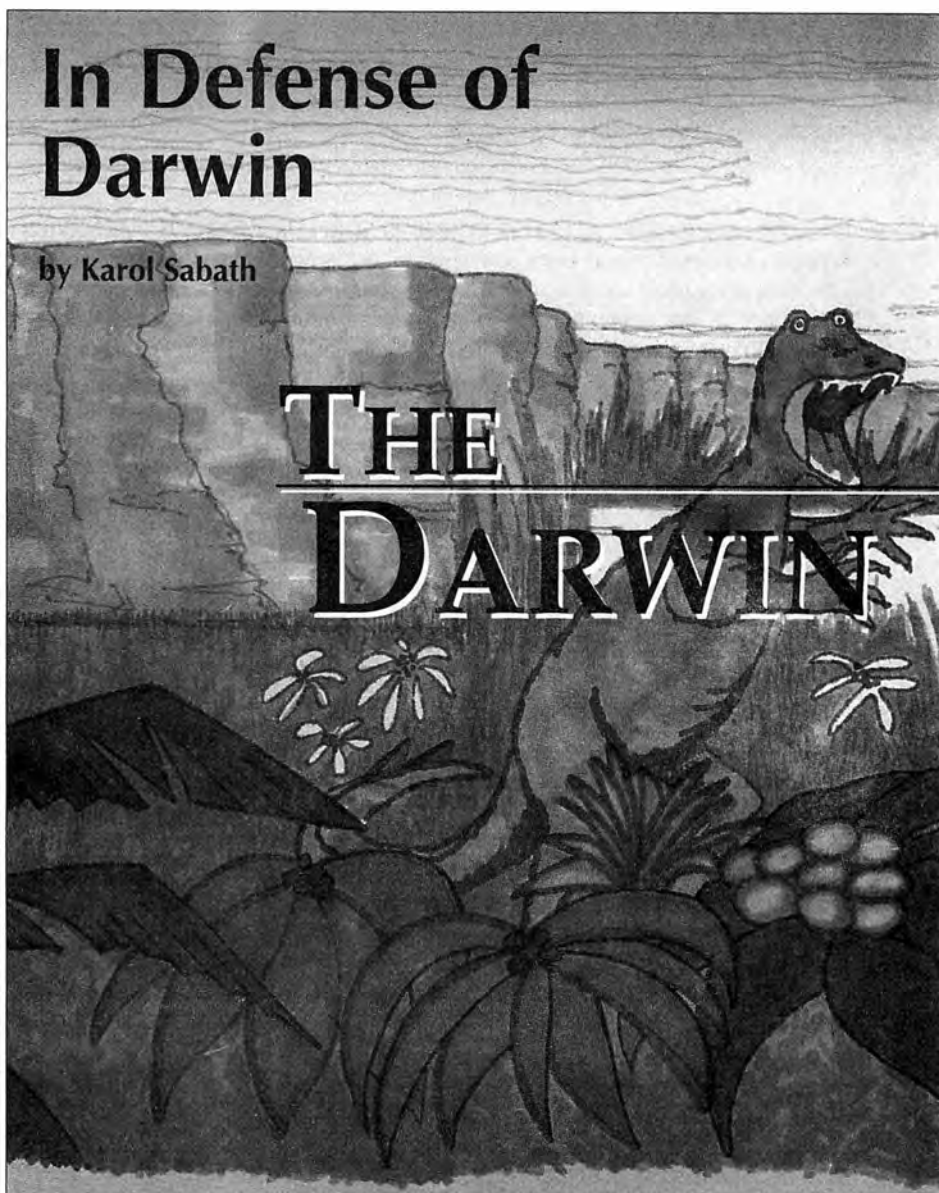

analysis of the current state of knowledge as the title implies.

#### **Crypto-creationism**

Calling support from outdated sources is however, not the only flaw in the author's reasoning. Many important scientific points are misrepresented, usually in a "crypto-creationist" way, that is, never explicitly denying the existence of evolution, but using Creationist arguments against Darwinism.

#### **(1) Chance and Random Changes**

The author quotes calculations showing almost zero probabilities of getting a molecule of optically active protein and proceeds to proclaim that "life could not possibly have begun without bringing in miracles from the outside." This is a typical Creationist argument against the nat-

ural origin of life.

I wonder how such sophisticated mathematics (or its mutations, like Fred Hoyle's "randomly assembled jumbo jet from a junkyard") can be seriously quoted in an apparently scientific journal.

This kind of calculation of *ex post facto* probabilities has been refuted long ago. One can find a popular example in *The Blind Watchmaker* by Richard Dawkins, for example. In the case of optically active organic compounds, usually both enantiomers (dissymmetrical forms) are produced randomly by chemical synthesis. The fact that in living things only one geometrical version is found results simply from the fact that most chemical reactions are catalyzed

*Continued on page 12*



# Bury Darwin— It's Overdue!

by Carol Hugunin

## DEBATE

### EDITOR'S NOTE

Carol Hugunin's article, "It's Time to Bury Darwin and Get On with Real Science," which appeared in the Spring 1995 issue (p. 32), provoked many responses. We print here, along with Hugunin's response, the comments of paleontologist Karol Sabath, who is writing his doctoral dissertation on dinosaurs at the Institute of Paleobiology of the Polish Academy of Sciences in Warsaw.

**K**arol Sabath's critique of "It's Time to Bury Darwin And Get On with Real Science" is most interesting in terms of his erroneous assumptions.

First, it is a myth that science is apolitical. The funding for scientific research is political. The determination of which scientific ideas are presented to naive undergraduate and graduate students is

also political; in the broad sense, it controls the way the next generation will think. Not only is the factual content and the methodology of science textbooks political, so also is the selection of thesis projects for graduate students.

Now, one may ask, why would political forces be interested in controlling science? If the human species were al-

lowed to rapidly develop new and better ideas, leading to new and better technologies, inexpensive and unlimited energy sources, more nutritious food, rapid advances in medicine, and higher standards of living, why would anyone bow down to political power? Why would anyone kowtow to the brutish sort of political power that says, "I have a persuasive group of paid thugs, I have money, I have control of what is printed in textbooks and the press, and you will do as I say"? Why wouldn't we just laugh at such characters and put them in mental institutions?

However, if future students are taught only ideas that are confusing and sterile, they will be less able to produce better technologies and higher living standards. In this situation, everything becomes scarce, and that wealthy brute can continue to maintain power, by hoarding and speculating on food and on raw materials.

And so, we, gullible humans that we are, are duped and intellectually incapacitated by our lack of knowledge of the history of epistemological fights in science. In this regard, it is useful—and, in fact, essential, to look at what other scientific currents thought about evolution, during the period that Darwin was formulating his ideas.

### A Malthusian Swindle

A look at the history of the period when Darwin wrote shows that a Malthusian political-social thesis was projected into the realm of the evolution of life. In other words, the biological sciences were swindled—forced into a political framework.

Darwin openly admits this. In his diary entry dated October 1838, he says that he borrowed his hypothesis directly from Thomas Malthus, a proponent of specific eugenics "solutions" to problems of England's poor, solutions later codified as England's Poor Laws. Darwin applied this to his biological data from the voyage on the *HMS Beagle*. The original title of Darwin's 1859 opus was *Origin of Species by Means of Natural Selection, or the Preservation of Favored Races in the Struggle for Life*.

Malthus, in turn, had taken his thesis on carrying capacity from the Venetian monk Giammaria Ortes.<sup>1</sup> The Venetians were the ones who would do anything, even pirating and selling their fellow Eu-

*Continued on page 13*

Continued from page 10

by enzymes, which have shape-specific active sites.

Thus, using racemic (mixed) versions of each biological compound would necessitate doubling the number of enzymes encoded in the DNA of each organism, which would be both redundant (duplicating each metabolic pathway) and stretching the chance calculation even further toward zero (two meaningful sequences of DNA would be necessary for each active molecule, and the probability of getting such a pair each time a new metabolic function arises is much, much smaller than for a single gene).<sup>1</sup>

The question of the nature of the universe (or at least whether it is entropic or not) is better left to astrophysicists than to Darwin. Anyway, it seems to me that Hugunin believes that the universe is nonentropic and nonrandom with only local entropy. It is worth noting that the consensus among scientists is just the opposite: The whole universe is entropic (the Second Law of Thermodynamics), and organisms (as well as the whole biosphere) are only local negentropic open systems (at the cost of energy from outside, of course, and only for a finite time).

The development of man is not especially "sudden" and thus mysterious. If we look at the measurable characteristics, like cranial capacity, we can see that during the last 4 million years hominid brains have approximately doubled in volume (from ape level of about 600 ml to about 1,400 ml in humans; part of the increase is simply the result of changes in body size from australopithecines to modern man).

Such a doubling is hardly a miracle. In modern human populations the largest brains are twice as big as the smallest ones (both being functionally normal). The average brain-size increase (or cephalization increase, to use Dana's term) in 200,000 generations would thus be less than 1/1000 of 1 percent per generation, which is perfectly explainable within standard models of natural selection and well below the actual rate of evolution observed in many lineages. Most human features have changed less dramatically than the brain in the last few million years.<sup>2</sup>

Another typically Creationist argument is the alleged absence of all missing



Author Karol Sabath with the first skull of *T. rex* at the American Museum of Natural History in New York City.

links. The author quotes the evolution of horses to prove this. She states that there are only six stages in this lineage, "starting with Hyracotherium and Eohippus in the Eocene period, but each intermediate stage appears abruptly." At least this is not only philosophical rhetoric, but some facts.

And what do we see? First, that the author is as well trained in paleontology as she is in the history of Victorian science. The Eocene is not a period, but an epoch of the Tertiary period. *Hyracotherium* and *Eohippus* are not two animals but one; *Eohippus* is a junior synonym for *Hyracotherium*. And there are only six separate stages in the classical 19th century diagram by O.C. Marsh, often reproduced in textbooks.

But if someone tries to change paradigms of the whole of modern natural sciences, why not check such a fact in some current technical paper, instead of a simplified, and more than 100-year-old schoolbook drawing? There are many more fossil horses known than six, and they do not appear abruptly, where the geological record is not abrupt for sedimentary reasons. To the contrary, small variations and gradual changes in all features (like tooth crowns, foot structure, and so on) can be observed be-

tween subsequent forms.<sup>3</sup>

Nor is it true, as claimed in a caption [The Evolution of the Horse, p. 44], that "If evolution followed the linear model of Darwin, the evolutionary path of the modern horse would not look like a complex tree with many branches. . . . Instead it would be a straight line. . . ." Darwinian evolutionists use the tree as a good model of phylogenetic pattern. Local populations encounter varying local conditions; somewhere a random mutation appears that is absent in other groups, and so on.

Thus the local populations begin to differ, and are transformed into new variations, subspecies, species, and subsequently genera—shown as branches on the picture. Some of them die out as the conditions change, some migrate and give rise to new populations, and so on. A straight line would result from the author's favorite model: "directed, nonrandom, purposeful, teleological."

#### Directedness in Development

Again, we are presented with pre-Darwinian wisdom about final causes and the beauty of the work of God the Creator, his intellect and hands. This is an interesting piece of history of natural philosophy and also a typical Creationist

Continued on page 14



Continued from page 11

European Christians into slavery, to maintain power.

Likewise, contrary to common belief, Darwin and the Darwinians borrowed the terms "survival of the fittest," and "struggle for existence" directly from Herbert Spencer, well known as the fa-

Leonard, was a major proponent of eugenics and he wrote a book titled *The Need for Eugenic Reform*. Leonard wrote that the book was "dedicated to the memory of my father. For if I had not believed that he would have wished me to give such help as I could towards making his life's work of service to mankind, I should never have been led to write this book."

As just these few items indicate, there is no Chinese wall separating Darwin and his theory from the political and social policy of eugenics, and the influence has not all been in one direction.

The same ties to eugenics policy are found among the authors of the modern synthesis of Darwinism: Sir Ronald Aylmer Fisher, the British geneticist, was the Galton professor of eugenics at the Francis Galton laboratory of University College, London from 1933 to 1943. Ernst Mayr was director of the American Eugenics Society in 1985 and

1986. Theodosius Dobzhansky was director of the Eugenics Society from 1964 to 1973, and chairman of the board of the Eugenics Society from 1969 to 1975. Sir Julian Sorrell Huxley was a member of the Council of the Eugenics Society in England (its executive council) from 1931 to 1932, vice president of the Eugenics Society from 1937 to 1944, and its president from 1959 to 1962.<sup>2</sup>

Huxley, perhaps the most famous of those involved in creating the modern synthesis, wrote in a 1924 letter to the editor of *The New Statesman*: "baboons or Australian savages can have all these [cultural] advantages, and will not blossom beyond their limits—limits set by their inheritance." In the same letter, Huxley also said, "The selection for survival has been enormously weakened by

modern medicine . . . sanitation . . . welfare . . . pity." He also proposed that the number of poor, feeble-minded human beings could be cut in half with a policy of mass sterilization.

#### Darwin's Eugenics Alive and Well

Darwinism is still alive and well, deeply embedded in the free enterprise ideology, which has the same arguments as the eugenicists of Darwin's day: The poor should be dumped on the scrap heap, thus leaving more resources for the genetically superior elite—in other words, for themselves. Proponents of this ideology argue that countries should not industrialize; instead they should extract raw materials for export, and use only appropriate-technology agriculture to grow food or narcotic drugs. Their raw materials often are processed and sold back to the impoverished producers at exorbitant prices.

Who controls the contents of textbooks that teach this ideology? Did it ever occur to Mr. Sabath, that it is more effective and less costly to enforce policies that are not in the self-interest of a population by controlling textbooks and the media, than by employing thugs?

A recent variety of this elitist argument is that man's development in general is bad for biodiversity because it tramples on other species. One version of the argument—that human economic development hurts the environment—by Nobel economist Kenneth Arrow and others, titled "Economic Growth, Carrying Capacity, and the Environment,"<sup>3</sup> was refuted at length by economist Lyndon LaRouche, whose concept makes it possible to measure the demographic correlates of discontinuous transformations in technological development.<sup>4</sup>

---

**"Man has no fixed biological way of life; he has no genetically determined job description."**

---

The application of Darwin's ideas to the political-economic realm might make Sabath uncomfortable, given the infamy the Nazis achieved by implementing eugenics ideas. But, these are Darwin's ideas, and their application does lead to fascism. Daniel Dennett recognizes this in his book, *Darwin's*

Continued on page 15

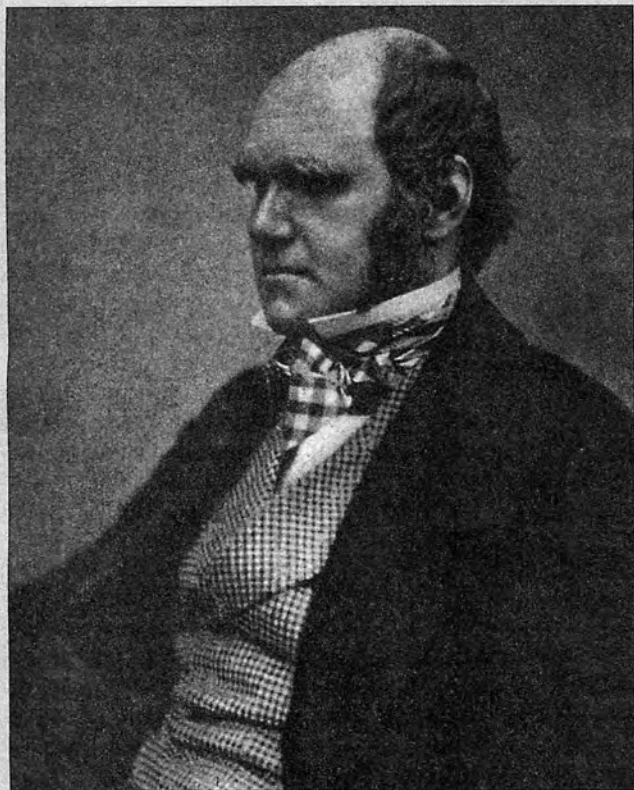

From Geoffrey West, *Charles Darwin: A Portrait* (New Haven: Yale University Press, 1938). Charles Darwin, shown here in 1854, fit his theory to the Malthusian mold.

ther of Social Darwinism and an active proponent of culling the human species of its "good-for-nothings."

Darwin wrote in *The Descent of Man*, "at some future period, not very distant as measured by centuries, the civilized races of man will almost certainly exterminate and replace the savage races throughout the world." In 1837, after Darwin returned from his voyage, he lived with his older brother, Erasmus, in London, and Erasmus's common-law wife, Harriet Martineau, who was known politically as the outspoken proponent of the aging Malthus. In 1831, Martineau wrote a work called "Poor Laws and Paupers Illustrated."

Charles and Erasmus's cousin, Francis Galton, is considered to be the father of British eugenics. Charles Darwin's son,

*Continued from page 12*

argument, but the author seems not aware that since the 19th century such arguments have been refuted by showing how the supposedly "purposefully designed" structures and functions came into being.

Because she invokes Riemann's admiration of the perfection of the ear and hearing, I can only again suggest reading Richard Dawkins, who brilliantly analyzes such concepts in his book *The Blind Watchmaker*. Paleontologists have also shown how the human ear developed from the jaw apparatus in fishes through amphibians and mammal-like reptiles, by remodelling hyomandibular, articular, and quadrate bones into middle-ear ossicles. But this knowledge comes from hard evidence gathered in our century; that is, from the period neglected in Hugunin's paper.

## (2) Continuous, Gradual Mutation

After recapitulating "assumptions" and "hypothesizing" of evolutionary mechanisms leading through genetic changes to speciation, Hugunin asks, "But then how could one explain much larger changes, such as . . . the differences in different families within the animal kingdom?"

The answer is simple. What we now see as families were once genera, and even before, mere species, not much different from each other. It is only *ex post facto* that we can say: "In 20 million years the descendants of this fossil species will develop into a family A and those of its sibling into family B." It is as if we were to say: "Well, we understand how isolation produces dialects, and we know that American English naturally diverged from British English. But how could one explain much larger changes, such as those between the English and German languages, or in the Indo-European linguistic family?" Again, exactly the same applies: by accumulation of minor changes in separate lineages.

The attitude toward evolution of species (as hardly explainable) and higher taxa (impossible to explain in Darwinian terms) is borrowed directly from creationists: They also reluctantly accept the idea of minor genetic variation and even speciation within "created kinds," but strongly reject any explanations of origins of higher taxa by Darwinian means.

Here Hugunin proceeds to demonstrate that "Darwin, who wrote a monumental work on the origin of species,

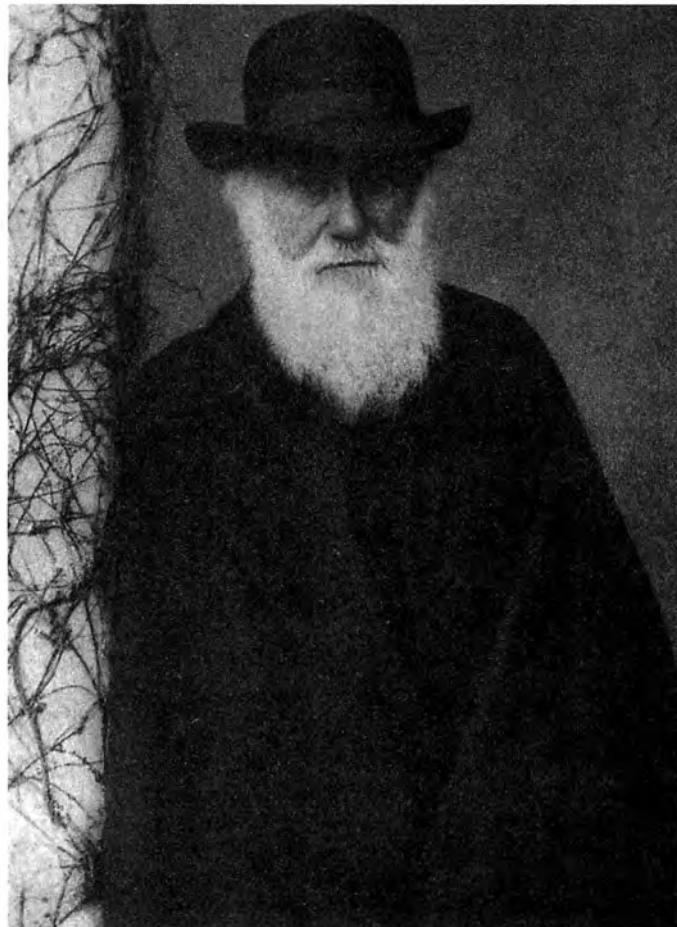

*From Geoffrey West, Charles Darwin: A Portrait (New Haven: Yale University Press, 1938). Darwin in 1881.*

does not even believe in species!" She proves this (again in a typically Creationist way) by manipulating a quotation. Darwin wrote that he came to "the heterodox conclusion that there are no such things as independently created species. That species are only strongly defined varieties."

The key words are, of course, "independently created species." In other words, Darwin no longer believed in independent creation of each species. He

concluded that the species originated as varieties, which became strongly defined (now we would say: reproductively isolated). This is the idea of evolution itself, and this is how modern biologists see species!

As a positive example of continental science, the author offers a long quotation from von Baer ("by 1834," in fact the quote was assembled from his writings of 1827 and 1828, but decades before Darwin's *On the Origin of Species*). We are presented here with the well-known hierarchy of biological systematics plus a fuzzy "scientific explanation" of the observed pattern: "The cause must lie in the essence of the forms themselves." Or: "all potential for variation is not actually developed because environmental factors must be conducive for the potential capacity in order for variation to be realized."

If this is the way "real science" should look according to Hugunin, I'd rather stick to Darwin.

## (3) Survival of the Fittest

The author claims that "the Darwinian view stresses a fierce dog-eat-dog competition: survival of the fittest," and in the penultimate sentence of this section: "the Darwinian model of individual dog-eat-dog fights to the death."

One need only look into *On the Origin of Species* or into most textbooks to see that this suggestion is false. Natural selection does not normally operate by cruel duels between

members of the same species, but by the differential survival of different individuals, with the main mortality factors being predators, illnesses, and so on, not mortal combats within species.

Another old charge against Darwinism, now often repeated only among Creationists, is the supposed tautology of the "survival of the fittest," where the fittest is the one that survives. The reason that it is not a tautology is that the sur-

*Continued on page 16*



Continued from page 13

*Dangerous Idea.*<sup>5</sup> Dennett correctly asserts that Darwin's ideas are a sort of universal acid, and says that they can and have been applied in ways that destroy the civilized nature of human life.

Darwin the man may be long gone, but his ideas and his method of thinking are still having corrosive effects on succeeding generations.

The same can be said for Darwin's impact in the biological sciences today, where the major assumptions of Darwinian science are still alive and well. For example, Darwin argued that an accumulation of very small changes slowly creates a divergence of populations, from which new species emerge. The modern synthesis argues the same thing, adding that those genetic changes are random, gradual, very small changes on the gene level.

The scientific opposition to the modern synthesis argues for punctuated equilibrium, governed by, in Stephen Jay Gould's words, "contingency," a pseudonym for chance.

Why should scientists accept a situation where the choice is between very gradual changes governed by chance, or very abrupt radical changes governed by chance?

How can Sabath explain his own existence by chance or by its correlative, entropy? If the universe is governed by chance and entropy, how does Sabath explain the fact that we can each argue in a possibly ingenious, possibly even creative manner, each heatedly defending his own hypothesis about the way the universe works? Isn't it ironic, according to Sabath's view of the universe, that what he most cherishes about himself is nothing but a temporary mistake (or a series of temporary mistakes) that denies the laws of chance and entropy?

Sabath mentions the arguments of Richard Dawkins, but beware the sleight of hand in such works of Dawkins as *The Blind Watchmaker!* According to the laws of probability, a change does not become more probable if one huge, complicated, rapid change is broken down into a series of tiny steps, each of which must occur sequentially to arrive at the same end at which the large, punctuated change would arrive.

It may become more plausible to the credulous reader, particularly if the ar-

gument is made that there is a long, long time for each little change to occur by chance. But this also is a fallacy; in reality, the Earth cooled at a specific point in time, life evolved at a specific point in time, eukaryotes evolved at a specific point in time, and man evolved at a specific point in time—all of which are known, within a certain margin of error, to science by various techniques for dating rocks. This means that there are sharp temporal boundary conditions

changes to have occurred by chance. Real time, as accurate as science can currently determine it through paleontology, leads to the same paradox.<sup>6</sup>

#### The Errors of Fundamentalism

Another wild assumption Sabath makes is that anyone who argues that man is higher than a beast must be a Christian fundamentalist. Wait a minute! The Creationists have an irrational, literal interpretation of the Bible. That is a direct denial of the role of

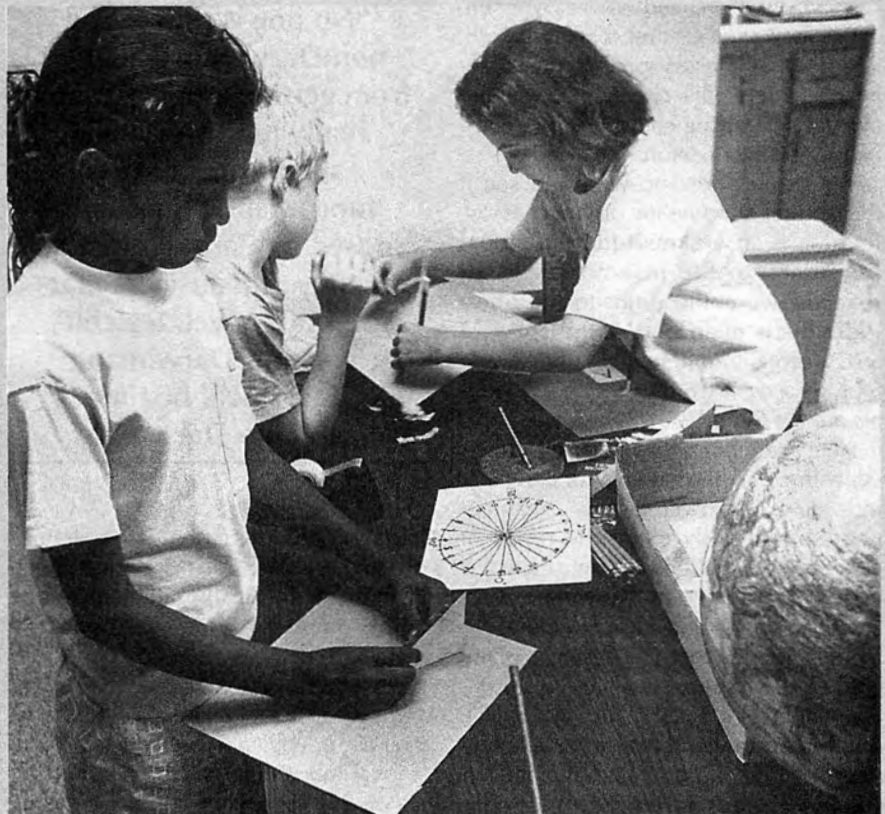

Stuart K. Lewis/EIRNS

*"Human beings have genetically changed at a much slower rate than rats or monkeys because humans use creativity to evolve further, whereas lower species are more dependent on genetic changes to evolve." Here children making sundials.*

or limits, within which all those myriad tiny changes would have to occur to get from a cooling Earth, with a solidified crust, to the evolution of life.

Once one starts looking at those temporal boundary conditions, one begins to discover that it is not possible for all those tiny changes to have each occurred sequentially by chance. There was not enough time. It is not necessary to use that strange Creationist view of time, in which the Earth cooled shortly before recorded history, to run out of time for all those sequential tiny

man's mind, man's ability to think metaphorically, in receiving the divine message.

And this is precisely the point: man's difference from animals is his ability to think metaphorically. To assert that anyone who says man is not an animal must be a fundamentalist, is a very serious error, which, in fact, denies the truth of Christianity and Judaism: Man is not a beast, but was created in the likeness of God as Composer or Creator of the Universe, *imago viva dei*. This

Continued on page 17



*Continued from page 14*

vival is not entirely random. It means that survival is only the common denominator, and the lower mortality ratio of a given phenotype is a convenient measure of fitness, but the reason for it is determined by adaptive features.

Let's look at an example. If we take a population of cockroaches and spray them with an insecticide, some of them will survive, thus proving they are the fittest (in these environmental conditions). But they are not the fittest because they are survivors, and not survivors because they are the fittest. They are both, because they possess some particular genetic feature, in this case perhaps a more efficient detoxifying enzyme or more impermeable exoskeleton.

We do not need to wait and see if the animal survives in order to assess its fitness. If we knew the individual resistance to the insecticide in all roaches, we could point to the fittest individuals even before the survival test. Normally, differential survival and reproduction just show which individuals are the fittest.

Here Hugunin shows lack of knowledge, implying that survival of particular individuals in "lower species" "may appear superficially to be the result of chance," and that this chance survival is what the "Malthusian-Darwinian view" assumes. The whole idea of natural selection implies that the survival is not entirely the result of chance, but of differential fitness. Totally random survival, not discriminating in respect to adaptedness or fitness, is postulated by non-Darwinian models of evolution. And a prodigious number of offspring and/or cannibalism versus parental care of a few offspring is not related to being "lowest" or "highest" species, whatever that means. (Is a bee higher or lower than a frog or a coconut palm higher or lower than an oak?)

It is just the K-strategy versus the r-strategy. The latter maximizes reproductive success by means of producing as many offspring as possible. It is typical of organisms living in variable, unpredictable habitats. Inhabitants of stable habitats are usually K-strategists (a small number of well-equipped offspring).

I was also amazed to read that "most higher mammals have elaborate social structures and extensive collective nurturing of the young." Even within the

apes (which, I guess, are "the highest" mammals), some live in bigger groups (chimps) and some in polygamous families (gorillas). Thus the social structure is about as elaborate as in the pricklefish, and much simpler than in ants. Some even live as isolated couples (gibbons) or solo (orangutans). None exhibits "extensive collective nurturing of the young"; usually it is the mother who carries and feeds her offspring.

I wonder which mammals the author

---

**"No one is preventing non-Darwinian scientists from getting 'down to some really hard work' and answering all the fundamental questions posed by Carol Hugunin. If they find answers that are both novel, testable, and anti-Darwinian, then it will be time to bury Darwin."**

---

had in mind. The reproductive strategy of "higher" and "lower" species need not be "so drastically different" as the author implies. Of course, birds and mammals, being endotherms, can afford more intense parental care than other vertebrates, but there are also sharks that bear live young (and few of them).

#### **(4) Inbreeding vs. Outbreeding**

Pointing to limitations of inbreeding of better varieties by human breeders (increase in serious genetic diseases, poor temperament, and so on) is another Creationist argument. Artificially bred domestic animals come from very limited populations (few breeders can afford a stable population of, say, 10,000 race horses), and thus are often close kin. This increases the risk of homozygous lethal or sublethal gene alleles. Natural selection, however, operates on larger populations, and this risk is minimized.

Another difference is that people usually breed animals or plants for a single trait (milky cows, brighter flowers, larger grain, and so on). Thus they often get a maximum performer in one respect, but one that is flawed in other respects.

In nature such a form would be quickly eliminated, because natural selection is not concentrating on any particular feature, but on the overall fitness; that is, the reproductive success. There are also natural selection mechanisms preventing inbreeding in natural populations.<sup>4</sup> Nevertheless, some analogies with the human-bred champions can be found in nature, in cases of sexual selection.

In these cases, where the reproductive success depends strongly on pleasing some particular and exaggerated expectations of members of the opposite sex (just as the reproductive success of a domestic animal depends on possessing particular traits favored by the farmer), the selection can lead to otherwise poorly adapted "champions" (males with a huge, apparently counter-adaptive burden of enormous antlers, bright feathers bringing predators' attention and making flying difficult, and so on). So here natural selection is very much like artificial selection.

It is not clear why Hugunin links the inbreeding problem with, and seriously refutes, the absurd "view [which] assumes that the environment—nature—remains fixed and stable." Certainly it is not a Darwinian view. Darwin opposed the idea of fixed nature and replaced it with the idea of evolving nature. Just because each living and evolving thing is an important element of others' environment, evolution proceeds in a changing environment (not to mention the climatic changes, and so on). Darwinism never assumed that organisms should be selected for lack of flexibility and vigor, as the author strangely seems to assume. Such terms as "coevolution," "evolutionary arms race," "Red Queen hypothesis" all explore the dynamic nature of adaptation.

Some species are more specialized and stenotopic (adapted to a narrow range of environmental parameters) and some are more generalized, eurytopic. The former can thrive in very stable conditions (ocean depths, caves), the latter pay a price of less than perfect adaptation to any given habitat, but can survive even drastic changes. The adaptations can be of different form, and both narrowly specialized and more adaptable forms can occur in closely related taxa.

Let's take the example of our genus,  
*Continued on page 18*

Continued from page 15

means that man emulates the Creator, to the best of his ability, by transforming the universe.

*Imago viva dei* does not mean that God is in man's image, but that man is in the Composer's image, inasmuch as he is capable of participating in the mind of the Composer of the universe, to understand causally how the universe developed and to apply that knowledge to further transform the universe. Man is higher than a mere beast because he has this metaphorical (that is, nonliteral) capacity to hypothesize a higher hypothesis.

True, the monotheistic religions agree that man will never have an absolutely perfect understanding of the nature of the universe, but all assert that man can approximate this understanding with greater and greater perfection. It is part of the fallacy of fundamentalist thinking to assume that the Bible (or Koran) must be taken literally, so that God's time, the time of the Eternal, of the Infinite, is reduced to man's simple notion of everyday alarm-clock time. What makes this approach evil is that it denies the mind of man. It says to each child who asks "why?" that "You can never know why. God made this, and this God is unknowable."

In its denial of man's mind, Creationism, and other forms of fundamentalism, come together with extreme materialism. The great mechanist and Marxist, Frederick Engels, claimed that the key to man's development was his opposable thumb—in effect, the capacity of some ape to hold a stick and use it to push termites out of a termite colony. In this claim, Engels makes exactly the same hideous mistake as the fundamentalists: He denies what is sacred about man, his ability to think, to create, to emulate directly his Creator by continuing creation.

Why should having an opposable thumb be important? There are other, non-primate species that employ things that can be construed as crude tools, but none of them, nor non-human primates, can do what man can do with his creative reason.

### The Uniqueness of Man

One of the best examples of this comes from Polish archaeology. Polish scientists discovered a carved ivory mammoth tusk, roughly resembling a boomerang in shape, in a prehistoric hu-



From Geoffrey West, *Charles Darwin: A Portrait* (New Haven: Yale University Press, 1938).

Darwin's older brother, Dr. Erasmus Darwin (above), and Erasmus's common-law wife, Harriet Martineau, were active in the Malthusian eugenicist faction in the mid-19th century.

man site, thought to be from about 20,300 years ago. This particular carved tusk is not a boomerang that returns to the thrower when thrown, but rather a killing stick with lift; it flies about 123 feet when thrown into oncoming wind, which gives it the lift. The glacier-dominated Europe of 20,300 years ago favored grasslands populated with large grazing mammals, such as reindeer, which could be killed readily with such an instrument.

What kind of species would deliberately carve something in a shape that would give it lift? We might look at this tusk as simply some kind of tool. If we gave it to different species, what would they do with it?

A dog, for example, would be delighted. He would drag it around, perhaps even shake it back and forth. Eventually, he would settle down to explore it in a very dog-like way: by chewing on it. Does he understand it as a potential tool? Obviously not.

What if we gave it to a quasi-upright ape? He too would be delighted. He would drag it around, throw it around, use it for poking at things. He might use

it in some crude way as a tool, but he would not take advantage of how it was designed to be used. Nor would he have any idea of how to make another one, or how to experiment aerodynamically to develop a still better carved tusk.

Clearly, contrary to Engels' claims, apes and man are two totally different species, with completely different ways of living. There is a true discontinuity between them. When man first evolved, he was no longer an upright scavenger with some funny opposable thumb. He was employing creative ideas—ideas couched in metaphors of language and culture, including poetry, music, and cave paintings.

Man's ideas, albeit imperfect ones, included thoughts about aerodynamics, particularly (initially) as they might apply to the task of hunting under the strange conditions imposed by the ice ages. And his ideas were about hunting strategy, or astronomical cycles, or about the development of a whole succession of more and more sophisticated tools and other more advanced technologies. His ideas also concerned the earliest uses of fire—

*Continued on page 19*

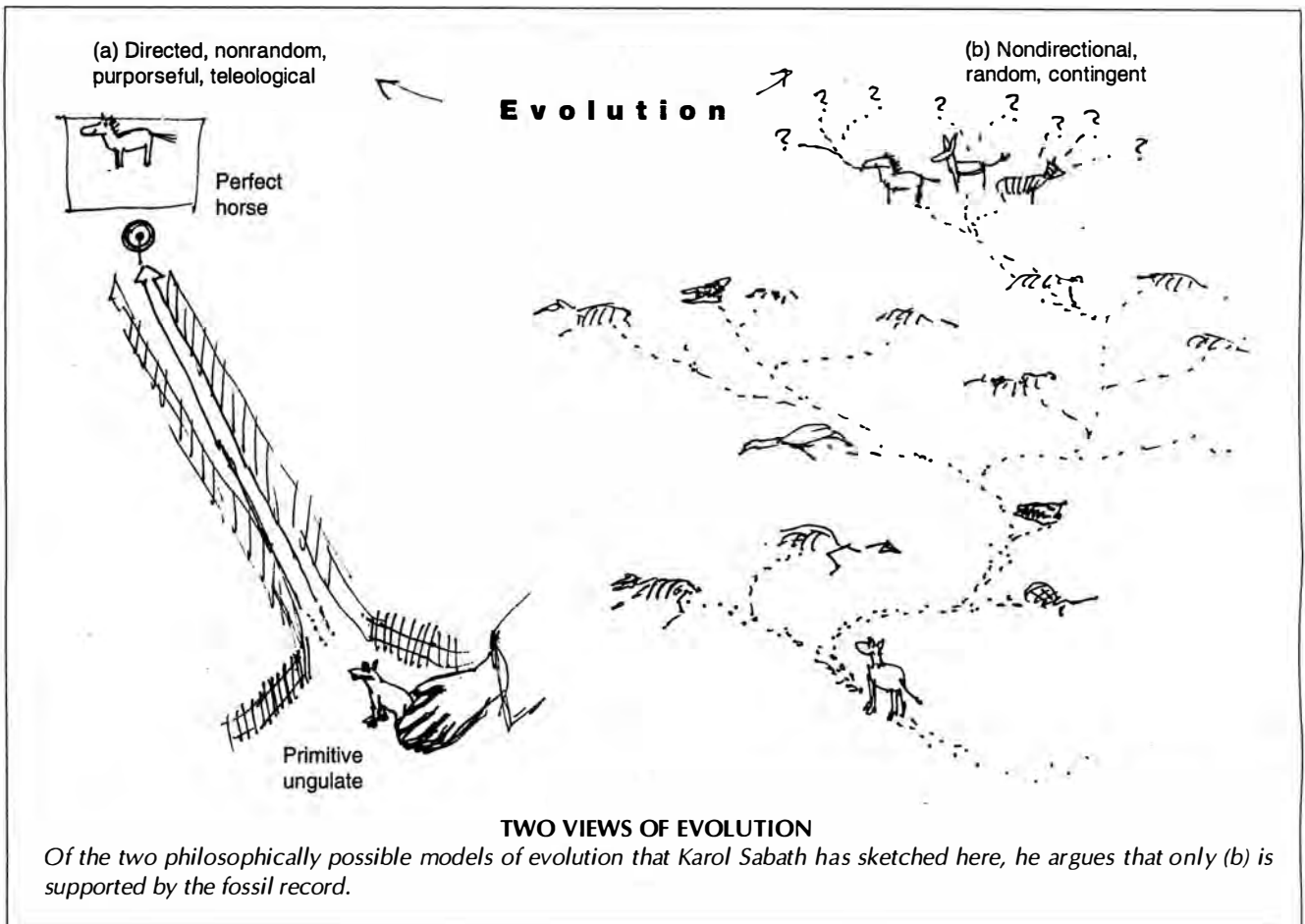

Continued from page 16

*Homo*. One form of human was adapted physiologically to harsh periglacial conditions. The Neanderthals of both sexes were extremely heavily muscled, thus producing a lot of metabolic heat; their noses were very big to allow efficient flow and "conditioning" of the air, fueling the metabolic oven with lots of oxygen. They needed more calories, so they specialized in eating large mammals of the Ice Age. Another, closely related lineage of humans has "chosen" another strategy: cultural adaptation (better tools, more efficient cooperation, more diverse diet, extensive use of fire and clothing instead of stronger muscles and larger noses).

Thus it is absurd to state that "man appears in Darwinian terms to be the least adjusted to environmental conditions, being both weak and naked." I wonder if the author ever imagined our ancestors running after prey in the African savanna, under tropical sun, in a thick fur cover. Our naked skin is perfectly

adapted to the place where we evolved, and to our ancestors' hunting and scavenging mode of life.

Neither are we extremely weak. Human beings can endure longer runs than most other mammals, which develop symptoms of thermal shock. Of course, our strategy of adaptation has for a long time not relied on muscle strength or other physiological adaptations, but rather on cultural ones. Darwinism does not state that all adaptations must be physiological, however; there are many examples of behavioral adaptation.

There is no "general lawfulness of evolution that is not unique to man: Life forms evolve to generate new species with greater versatility and greater capacity to transform the biosphere." In my opinion these assumptions are false. The most versatile forms are microorganisms. They live in both hot springs and glaciers, in ocean depths, and in other organisms. They have managed to survive successfully for almost 4 billion years.

Microorganisms also have a great capacity to transform the biosphere. They

created it, in fact. They also changed our atmosphere into one containing free oxygen, without doubt a major change, which occurred more than 1 billion years ago. On the other hand, I do not see many recent additions to the animal kingdom (except *Homo sapiens*) that would show remarkably greater capacity to transform the biosphere than the earlier forms did.

I would also be cautious in comparing the number of species extinctions caused by humans with those resulting from prior environmental changes. Neither drifting continents nor asteroids have consciousness or moral responsibility. Humans are the main extinction factor in the last thousands of years. See, for example, the data on Pacific Islands birds exterminated by human settlers.<sup>5</sup> About one quarter of all bird species in the world has become extinct in the last few thousand years; this is already a sudden mass extinction by paleontological standards.

And many more people have de-

*Continued on page 20*



Continued from page 17

not just accidentally to char meat, but systematically to develop more and more sophisticated tools by developing them at higher and higher densities of energy throughput. Likewise, he developed ideas about fishing strategies and even navigation at sea, ideas about plant and animal husbandry, and so on.

### Not Just Language

Let's discuss another illusion about what makes man human. Some say, man is man because he talks, he can communicate; he uses some differentiated combination of grunts, moans, and other tones, with considerable nonverbal sign language, focused on the tremendous expressiveness of the human face, especially around the eyes.

This theory holds that ape-man started cooking his food, and this changed the geometry of his mouth and skull, chang-

ing the resonating cavities in his head. Therefore, he was able to articulate a language, a very sophisticated form of communication. Is this the process that makes man human—or is the theory backwards?

Consider this: Dogs speak "dog," a combination of moans, grunts, growls, and other tones, with considerable nonverbal sign language conveyed by body posture and a tremendous focus on the face, especially the eyes. Most dog owners, to the degree that they have been able to teach their dogs much in the realm of obedience or working skills (herding, police work, seeing-eye work, and so on), also speak dog. It's a common other-species communication system known to humans.

Dogs, however, have not a clue as to how to make a tool or what to do with an existing tool. Yet, as social creatures,

they have a well-developed communication system, akin to a primitive language. Parrots have fine resonating cavities in their heads and can babble away, mimicking any human language devised, without the slightest clue as to what they are repeating. Again, they have no conception of how to make a tool, or what to do with one.

Human beings developed sophisticated languages because they had profound conceptions to communicate; that is, after becoming the human species, the species of ideas. They did not become human because the shape of the skull changed, for whatever reason.

Man, the species of ideas, of higher hypotheses, clearly continually improves on the resources offered to him by raw nature, even to the degree of developing irrigation networks, artificial fertilizers,

Continued on page 21

## A Species of Ideas

This 20,300-year-old killing stick, a throwable weapon carved from a young mammoth's tusk, was found in the Oblazowa cave in the Polish Carpathians among other artifacts of Upper Palaeolithic human culture. It is identical in size and shape to the Queensland, Australia, non-returning wooden boomerang, but the Queensland boomerang is much lighter and considerably less stable when thrown under varying wind conditions.

One side of the mammoth's tusk has been polished to create a convex blade edge, and the handle end is more rounded for safer grip. This design generates lift when thrown into the wind—from downwind of the reindeer or other game. Subtle details in the way the tusk was carved improve the weapon's stability and ballistic qualities, indicating that the carver had considerable knowledge of aerodynamics based on a long tradition of making weapons of this sort. (The drawing shows cross-sections and their corresponding locations on the stick.)

Europe in the period 22,000 to 20,000 B.C. was a glacial grassland populated by large grazing mammals and dominated by a mile-high glacier covering most of the British Isles, all of Scandinavia, and ending just short of what would be today London, Hamburg, and Warsaw. The French cave paintings (Lascaux, Grotto Chauvet, and so on) come from this period and show serious study of animals—bulls, rhinoceroses, horses, bears, elk, reindeer, bison, lions, hyena, and others.

At this time, man had developed the use of a spear thrower; ivory sewing needles were used to fashion hide clothing; primitive torches and lamps were used; minerals

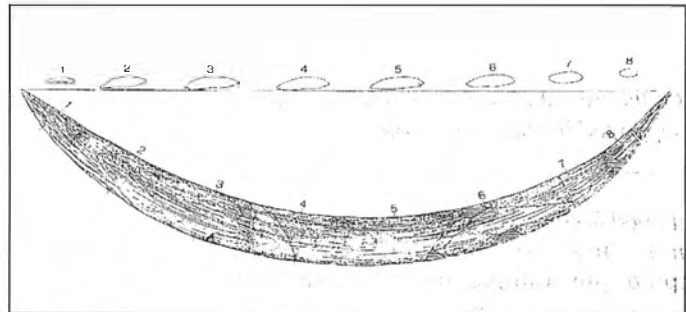

Dietrich Evers and Pawel Valde-Nowak, 1994, "Wurfversuche mit dem Jungpaläolithischen Wurfgerät aus der Oblazowa-Höhle in den polnischen Karpaten," *Archäologisches Korrespondenzblatt*, Vol. 24, Heft 2, p. 137.

were mined and combined with binders to produce pigments; edible nuts, fruits, and other plants were collected; and salmon, bird, and mammal migration patterns were studied and exploited.

In short, man was a species of *ideas*, relying on intelligence, skills, and developing technology and culture, rather than brute strength and wooden clubs.

Continued from page 18

stroyed various "beasts" than ever got to the Moon, of which the author is so proud. The blue-green algae changed the entire planet into a habitable place (you can thank them for the oxygen you breathe, and for the protective ozone layer), and so what? Are they the image of God the Creator, and humans the image of Daemon the Destroyer?

#### (5) Man Just a Beast?

Here it should be stressed that eugenics and Social Darwinism are neither part of the original Darwinian theory of evolution, nor part of the modern synthesis. No scientific theory can be falsified by exposing its abuse by politicians. The Hiroshima bomb did not falsify Einstein's theory or physics in general. Discrimination against poor people or other races did not begin with Darwin. Forced labor, slavery, and injustice existed before and were then (and later) justified by religious arguments. For example, South African apartheid was justified by abuse of the Old Testament, and the discrimination against Indian pariahs was justified by Hinduism.

And the "continental science" and philosophy, so praised by the author, was involved in the terror of the French Revolution, justifying tortures by the police, use of phrenology to indicate innate inclinations toward violent behavior, and so forth.

Cuvier made his political career—rising to the post of police minister in France—in the period when poor people were branded and sentenced to the galleys for minor crimes.

Why blame Darwin for all prejudice and injustice in the world?

#### (6) Darwin Duo: Reductionism And Holism

In this satire [pp. 36-37], we see that Hugunin does not speak of the real Darwin, who could not be reductionist and holist at the same time. She just uses his name to denote any modern natural science that is not explicitly Christian and full of supernatural assumptions.

First of all, I would expect Hugunin to show in her ironic style how the Christian-Platonic flea scientist would reach the proper answer about the nature of the beast they live on. By divine illumination, or what?

I can only point out that the reductionist team of fleas would probably launch some of their number into ex-

trabestial space. From the top of the trajectory, a jumping flea could take photographs of the dog, using a micro-camera (bought at the flea market). Analyzing the "satellite images," and comparing them to the data collected at the surface, the reductionist fleas could reach quite a good approximation of the dog geometry.

As for the British holists, I never heard of J.B.S. Haldane (or any one of them) worshipping the deteriorating conditions of living, or their subject of research, nor practicing human sacrifices of fellow scientists. Maybe it is irrelevant, but as far as I know, that was rather the practice of some Christian-Platonics who praised natural disasters and infectious diseases as a deserved and beneficial punishment by the Supreme Being and who occasionally burned someone at the stake to appease its anger. Anyway, I think that the treatment of holism is here definitely biased and unsubstantiated.

#### (7) The End of Darwin

I wonder where else, except in Creationist writings or some distorted early journalists' reports on the "punctuated equilibria" hypothesis, could the author find a claim that "the views of Darwin and friends do not stand up well to the massive amount of scientific evidence accumulated about how evolution works" or that "from the standpoint of the paleontological record and similar evidence [no evidence was shown by Hugunin], the Darwinian hypothesis is a miserable failure," or that one needs to expose "the fraud in the still-taught dogma that modern biology and physical anthropology rest upon Darwin's fundamental discovery."

Of course, no one is preventing non-Darwinian scientists from getting "down to some really hard work" and answering all the fundamental questions posed by Carol Hugunin. If they find answers that are both novel, testable, and anti-Darwinian, then it will be time to bury Darwin.

It is difficult to understand why the author shows such an urge to get completely rid of Darwin. Normally, people who feel that some old idea is wrong present a new, coherent theory that sooner or later could win majority support and become a new orthodoxy. Instead, Hugunin first of all misrepresents the view she dislikes, then as a replacement she proposes an even older and

long-ago rejected model: a mixture of science, religion, and philosophy, both vague and strongly influenced by subjective intuitions (or the common sense of a given time).

In reading Hugunin's paper, I feel as if I am being confronted with Creationists' school brochures that try to hide the real, religious reasons behind rejecting evolution. Even the arguments are the same. Actually, I am surprised that the author did not declare herself a Creationist, being so influenced by this view.

An "axiom of science" that "Man is in the image of God" appeared modestly only in the table on page 38. Now, she takes a hybrid view: believing in all traditional, Creationist anti-Darwinian tenets and yet still talking about evolution that is somehow driven by miracles to a final point, with no proof given. Such a post-modern, New Age-like, politically correct, conglomerate religious ("Christian-Platonic") view is only a sign of getting lost in contradictory arguments, but is not a constructive scientific proposition.

I am amazed that a "biologist on the staff" of a scientific journal that aims at the 21st century could show such a blatant misunderstanding of a fundamental idea of modern biology. I believe that readers deserve a fair treatment of this important matter.

#### Notes

1. For a brief resumé of current ideas, expressed during a conference on the problem, see Jeffrey L. Bada, 1995. "Origins of Homochirality," *Nature*, Vol. 374, pp. 594-595 (April 13).
2. See Ann Gibbons, 1995. "When It Comes to Evolution, Humans Are in the Slow Class," *Science*, Vol. 267, pp. 1907-1908 (March 31).
3. Concerning the number of fossil horse species and their mode of evolution, see for example, Bruce J. MacFadden, 1984. "Systematics and Phylogeny of *Hipparion*, *Neohipparion*, *Nannipus* and *Cormohipparion* (Mammalia, Equidae) from the Miocene and Pliocene of the New World," *Bulletin of the American Museum of Natural History*, Vol. 179 (1); B.J. MacFadden, 1988. "Fossil Horses from 'Eohippus' (*Hyraotherium*) to *Equus*. 2. Rates of Dental Evolution Revisited," *Biological Journal of the Linnean Society*, Vol. 35 (1), pp. 37-48; R.C. Hulbert, Jr. and B.J. MacFadden, 1991. "Morphological Transformation and Cladogenesis at the Base of the Adaptive Radiation of Miocene Hipsodont Horses," *American Museum Novitates*, 3000; as well as the references cited in these papers.
4. L.F. Keller et al., 1994. "Selection against Inbred Song Sparrows during a Natural Population Bottleneck," *Nature*, Vol. 372, pp. 356-357.
5. David W. Steadman, 1995. "Prehistoric Extinctions of Pacific Island Birds: Biodiversity Meets Zooarcheology," *Science*, Vol. 267, pp. 1123-1131.

Continued from page 19

better mining technologies, and so on. Man creates his own superseding technologies, which totally transform and redefine what can be considered as resources. No other species can do that; other species are trapped by the fixed biological nature of their way of life.

For a fixed way of life, there are only fixed resources and a fixed limit on population density. Man has no fixed biological way of life; he has no genetically determined job description. He is not limited to whatever can be accomplished by manipulating an opposable thumb. Man, with a whole succession of technologies, nurtured by developing culture, has transformed his potential population density by three orders of magnitude since the most primitive men first inhabited Earth.

### The Evolutionary Clock

In citing the conclusion that "When it comes to evolution, humans are in the slow class" (from *Science*, March 31, 1995), Sabath is deliberately ignoring the point being made by population geneticist Li Wen-Hsiung of the University of Texas at Houston.<sup>7</sup> According to the metric of DNA mutation rates, human beings have genetically changed at a much slower rate than rats or monkeys because humans use creativity to evolve further, whereas lower species are more dependent on genetic changes to evolve.

Human beings evolve on a different level from other species; they evolve on the level of ideas. This is what Li says, which, as he points out, makes the idea of a universal biological molecular clock (the rate of DNA mutations) a flawed construct, insofar as it assumes that species evolve at the same rate.

The molecular clock concept is also flawed and problematic because it assumes only vertical genetic change—from parent to offspring. In reality, horizontal genetic change—the transfer of genetic material from organism to organism (of the same or different species) by viruses and other parasites—is also possible under some circumstances.

Should we, therefore, give up science and join the fundamentalists in declaring the subject to be the unknowable act of an unknowable Aristotelian God? I think not. Instead we should broaden our study of epistemology and look at the historic fight between the Aris-

totelians and the Platonists. The Aristotelian dominance of academia has hidden the better approach of the Platonic currents: the Christian Platonic tradition that developed the concept of man as *imago viva dei*.

The "Philosophical Fragments" of Bernhard Riemann [see page 48, this issue], give a conceptual overview of this alternative. In the tradition of Plato, as defined by Nicholas of Cusa, Leonardo da Vinci, Johannes Kepler, and Gottfried Leibniz, Riemann develops a hydrodynamic approach to the universe in which the universe transforms itself by generating singularities. These singularities redefine the potential and topological characteristics (including change in metric and change in state) of the space-time manifold of that universe.

In short, Riemann develops a notion of an evolving, hydrodynamic self-transforming universe, in which entropy is not primary. Lyndon LaRouche is the most prominent thinker today developing ideas based on this tradition.

### The Vernadsky Example

In the earlier 20th century, the Ukrainian scientist Vladimir Vernadsky (1863-1945) looked at the evolution of life from a Riemannian perspective. Basing himself on the work of Riemann, Curie, and Mendeleev, Vernadsky began to elaborate that study. He was the first (at least the first known to this author) to elaborate the notion of the biosphere, as that portion of that Earth's crust and atmosphere that is dynamically transformed by the development of a powerful singularity: life.

Life has totally reworked the geological surface of this planet's crust. But the emergence of man is still another powerful singularity transforming the characteristics of the biosphere, and its potential rate of change. This development—man's transformation of the crust of this planet and its atmosphere—Vernadsky refers to as the noösphere. Because the school that developed around Vernadsky's ideas is itself heavily influenced by the empiricism that dominates modern science, an honest treatment of Vernadsky would take considerable space.<sup>8</sup>

What's wrong with the empiricist approach of modern science? Riemann is very explicit: in dealing with the teleological nature of the evolution of the biosphere and even the noösphere, reason by analogy—by metaphor—is supe-

rior to inductive laws generalized from what we observe about nature.

However, if such reasoning by analogy is mistakenly taken literally, reason aborts itself, and one is back to the sterility of Gaia, in which nothing is knowable. The biosphere evolves, in interaction with the mantle of the Earth and astrophysical phenomena as if it had a mind, as if it were a thinking being—planning the best of all possible worlds to set up the basis for future evolution of life. The biosphere acts in a purposeful manner; yet to think of it as a living being with a world brain is a dead end.

To my knowledge, the last scientist to take this sort of teleological approach was Lawrence Henderson in his 1913 book, *The Fitness of the Environment*, which argues that the Earth, with its hydrosphere, is physically, chemically, and in terms of protective climate, the best of all possible worlds for the evolution of life.<sup>9</sup>

Henderson states that the old teleology—the fundamentalist teleology that claims God made everything and humans cannot know how or why—is dead. However, he says, scientists can and must develop a new teleology, because the mechanistic hypothesis developed out of the realm of Epicurean chance cannot account for the purposefulness found in nature.

The challenge posed in my previous article remains: We have to revive the method of Riemann and do the really hard work necessary to answer the question, What is life and how did it evolve?

### Notes

1. Lyndon H. LaRouche, Jr., 1995. "Kenneth Arrow Runs Out of Ideas, But Not Words," *21st Century*, Fall, pp. 34-53.
2. Information concerning eugenics society members comes from records of the British and American eugenics societies compiled by researcher Kathy O'Keefe.
3. Kenneth Arrow, et al., 1995. "Economic Growth, Carrying Capacity, and the Environment," *Science* (April 28), p. 520.
4. See note 1.
5. Daniel C. Dennett, 1995. *Darwin's Dangerous Idea* (New York: Simon & Schuster).
6. For a broader review of the argument of Richard Dawkins, see Lyndon LaRouche, "On the Subject of God," *Fidelio* (Spring 1993), p. 17.
7. Ann Gibbons, 1995. "When It Comes to Evolution, Humans Are in the Slow Class," *Science* (March 31), pp. 1907-1908.
8. For space reasons, a section on Vernadsky's work was eliminated from my previous article, "It's Time to Bury Darwin."
9. Lawrence J. Henderson, 1913. *The Fitness of the Environment* (Gloucester, Mass.: Peter Smith, 1970).



# JOHANNES KEPLER'S MYSTERIUM COSMOGRAPHICUM

## A Guide to the Harmony of the Mind And the Universe



by Ralf Schauerhammer

*Four hundred years later, Kepler's first work  
still tells us more about the solar system  
and human creativity than Newton  
or any empiricist is capable of doing.*

Johannes Kepler discovered the harmonic ordering of the solar system in July 1595, precisely 400 years ago. The discovery was so important to him, that he recorded the date for posterity in the foreword to his *Mysterium Cosmographicum* (Mystery of the Universe). While he was alive, and after his death, in the middle of the horrors of the Thirty Years War, the fundamental features of Kepler's work were misunderstood and forgotten. Today, it is claimed that Kepler was the *forerunner* of the Newtonian theory of universal gravitation, but this is a complete misrepresentation of Kepler's genius. Kepler's physics and epistemology go far beyond anything that Isaac Newton, and the school named after him, are capable of knowing and explaining.

How diametrically opposite the two ways of thinking are, is expressed in the judgment of the "Newtonian" Pierre Simon

Laplace on Kepler's work. Laplace saw Kepler's ideas as "chimerical speculations" and thought that Kepler's search for a universal harmony was "depressing for the human spirit." Another great scientist, however, the mathematician Georg Cantor—whose theory of manifolds was based on the same Platonic conceptions to which Kepler also subscribed—warned against the "empiricist sect," which reduces explanations of nature to pure descriptions of phenomena (with formal "models") and makes real natural science impossible.

This "empiricist sect" has since puffed itself up to the rank of orthodoxy in science. That is why the *significance* of Kepler's work is still misunderstood, despite myriad symposia and research projects in the history of science. Kepler was not the forerunner of Newton and that kind of empirical science which, following Newton, "makes no hypotheses." For that



Ulla Cicconi

*A statue honoring Kepler in his birthplace Weil der Stadt, a town near Stuttgart.*

very reason, Kepler can provide us a crucial stimulus: It was Kepler, and not Copernicus, Newton, or Galileo, who made astronomy, cosmology, and physics into an entirely new science. What Kepler can teach us is the method for developing

entire manifolds of hypotheses in creative freedom and yet "lawfully" and, ultimately, empirically verifiable.

If we look upon the paradoxical quandary in which today's cosmology has entangled itself, or if we reflect upon the con-

---

#### EDITOR'S NOTE

---

*The original German-language version of this article appeared in Fusion, June 1995. Its Kepler quotations were taken from Max Caspar's German translation of the *Mysterium Cosmographicum*, published in 1936 by Dr. Benno Filser Verlag, Munich. Caspar, the foremost Kepler scholar of this century, rendered the original Latin into German in the style in which Kepler himself wrote in German. The English translation here of Kepler's quotations is by George Gregory, and is taken from Caspar's German. A more literal English translation can be found in the Abaris Books publication of the *Mysterium Cosmographicum* (New York, 1981), translated by A.M. Duncan with an introduction and commentary by E.J. Aiton.*

*The footnotes that appear with the text were added by Kepler when the text—unchanged—was republished 20 years later.*

*Ralf Schauerhammer works with the Fusion Energy Foundation in Germany and is the coauthor of *The Holes in the Ozone Scare: The Scientific Evidence That the Sky Isn't Falling*, published in 1992 by 21st Century.*

ceptual contradictions of quantum theory, to which Werner Heisenberg pointed shortly before his death, we see contradictions that have been ignored rather than solved. And if we notice the trend toward increasingly reckless *ad hoc* hypothesis and epicycles, then it is quite natural to hope for a new Johannes Kepler.

A number of important selections from Kepler's first work, the *Mysterium Cosmographicum*, are presented here. These are intended to allow the reader to immediately relive Kepler's own thinking. The selections may inspire some readers to read the entire work, and also others of Kepler's works, his *World Harmony* or the *New Astronomy*, for example.

Whoever does that with an open mind, will recognize how rich Kepler's thinking was. First, it will probably seem striking that Kepler does not think that the three planetary laws, named after him, are as important as is commonly assumed today. This assumption results from the already mentioned mistaken approach, which claims that Kepler was a "forerunner" of Newton, because the basic laws of Newtonian planetary mechanics can be derived easily from Kepler's laws. It will become evident in a number of passages that Kepler fully understood the quantitative features of the relationship of mass, space, and time, which are explained by universal gravitation according to Newton. Kepler, in fact—in his *Dream of the Moon*—was able to correctly predict the biological effects of minimal "gravitation" of the Moon's surface upon potential living beings. No such document by Newton is known.

Kepler's physics was far richer than that of Newton, Laplace, and other Newtonians. Kepler's harmonies imply a relativistic conception of space, which reemerged and was generally recognized in physics only in this century, in a different form, on the basis of earlier mathematical work by Bernhard Riemann. The depth of Kepler's method in physics is apparent when we look at the question of why the planets in the solar system rotate around the Sun with precisely those distance-relationships they have, and not with others. This question cannot be answered today, in any meaningful way, by the limited methods of Newtonian physics.

In the macrophysical realm, it has become impossible to pose the question of harmonic relationships (or "quantum orbits"). But in the microscopic realm, we are compelled to operate with harmonically ordered orbit-systems, such as the orbits of electrons in the atom, for example. Why do the empirical data of the atomic spectrum in the microcosm lead us to harmonic quantum orbits, while the harmonic relationships of the orbits of the planets, which Kepler calculated from the observational data of the visible anomalies of planetary movements, are inconceivable from the standpoint of today's physics? And why have the extremely precise relationships of harmonic intervals, which Kepler calculated for the planets in his *World Harmony*, remained the same as they were then, despite reciprocal influences (that is, the "perturbations" in the terminology of the Newtonian theory of gravitation)? And, one more question: Why was it possible to locate the planetary orbits for Uranus, Neptune, and Pluto, discovered after Kepler's death, precisely in these musical intervals?

Even with such questions, we have hardly reached the end of the problems confronting today's physics. Since we can no

longer give a meaningful answer to the question of the harmonic ordering of the distance-relationships of the planets in today's Newtonian physics, we look around for a substitute, a way of differentiating—or at least explaining—the actual planetary orbits among the infinitely many possible orbits. We find this explanation in the development of the solar system in time.

The issue is not that Kepler assumed the solar system and the universe to be fixed; he, too, hypothesized a development in time. But since Kepler's conception of harmony is *missing* in Newtonian physics, this physics *must* be based on a temporal development that permits the individual planetary movements to be calculated backwards, from their present positions. This must also be causally calculable from one step to the next, all the way back to the time when God originally wound up the great clock of the universe.

Today, of course, we no longer speak of a clockwork of the universe and about God. We talk about a "Big Bang," and we commit the blunder of thinking that we have found out something meaningful about the universe if we can design a model for what happened in the first nanosecond of these billions of years: a self-contradictory and methodologically ridiculous enterprise—and all of that, because we do not have Kepler's idea of harmony!

Kepler's concept of harmony is anything but the sort of mysticism that some New Age fanatics would like to make of it. Kepler explicitly states: "I do not want to prove anything with the mysticism of numbers, and I also do not think this is possible." Instead, Kepler simply acknowledges the fact that the multiplicity of geometrical forms cannot be taken from sense experience, but that they have their origins in the human endowment of Reason, which is the prerequisite for knowledge and scientific research about the world. Empiricist ideology vehemently denies this, and stubbornly throws itself into the "objective" description of the first millisecond of creation.

### Creativity in the Human Mind—and the Universe

Kepler, to the contrary, tells us, that we can only know something, as human beings endowed with Reason, to the extent that we "look over our own shoulders" when we know something; that we can only know something new to the extent that, in the act of knowing, we learn about our own creative capacity; and that we can only know nature, because the Reason in our minds and hearts corresponds exactly to the quality of the development of the universe, which we experience outside of our own persons.

In Kepler's words, this means:

od wanted to allow us to know the world when He created us in His image, so that we may participate in His own thoughts. For what besides numbers and magnitudes are in the mind of the human being? Only these do we correctly apprehend, and indeed, if piety permits it to be said, our knowledge is of the same kind as the Divine, at least so far as we are able to understand anything in our mortal lives.

If Kepler's religious way of expressing himself seems irritating, we should remember that God is the Creator who pro-



duced the laws of nature for which empiricism has hunted in vain in the form of the Big Bang.

Let this suffice as an introduction. We now turn to Kepler's *Mysterium Cosmographicum*.

---

### DEDICATION OF THE FIRST EDITION

---



I do not want to speak of the fact, that my subject is a weighty testimony for the fact of creation, which the philosophers have denied. For here we see how God, like a human architect, went about the work of designing the world, according to order and rules, and constructed everything according to measure, so that one could think, that it is not art which takes nature as its model, but God Himself in His Creation looked to the design of the future human beings.

This is the most important hypothesis for all of science: The world is knowable by human Reason, because the laws of nature are in accord with that Reason; but this natural lawfulness has to be understood more profoundly than is usually done today, and must also encompass, for example, the laws of "creativity" of classical works of art. Kepler continues:



I indeed, must the value of divine things be measured like a dinner in pennies? But, please, someone will say to me, of what good is the knowledge of nature to a hungry stomach, of what good is all of astronomy? Now, people of Reason do not listen to the ignorance which shrieks there, that such studies must not be undertaken. We tolerate the painter because he entertains the eyes, the musician the ears, although they are otherwise of no use to us. Yes, the pleasure we derive from their works is thought to be not only appropriate to human beings, it also does him honor. What ignorance, what stupidity, therefore, to gainsay the spirit a pleasure which is a fitting honor to him, but not to gainsay this pleasure to the eyes and ears! He does combat against nature, who combats against these pleasures! For the benevolent Creator who called Nature into existence out of nothing, did He not bequeath to each creature that which is necessary, and both beauty and desire in plentiful bounty?

Shall he have left the spirit of human beings, the master of all Creation, his own image, alone without inspiring delight? Yes, we do not ask for what pleasure the little bird hopes, when it sings; for we know, it takes pleasure in singing, because it was created to sing. Likewise, we may not ask why the human spirit expends so much effort to seek out the secrets of the heavens. Our architect created the spirit fitting to the senses, not only so that human beings may earn their livelihood—many sorts of creatures can do that more skilfully with their unreasonable souls—but also to that purpose, that we may penetrate to the being of things which we do not see

with our eyes, even were no other utility connected with it. And as the other creatures, so also the human body is sustained with food and drink, so the soul of man, which is different from the whole of man,\* kept alive by that sustenance of knowledge, enriched, and in a certain way promoted in growth. He who has no yearning for such things in him, more resembles a corpse than a living being.

What a scathing critique of many people today, and most of modern science, which has given up looking for the "being of things" and penetrating "to the causes of their being and becoming," and instead limits itself to making "models" that only "describe" empirical data and thus "more resemble a corpse than a living being."

---

### PREFACE TO THE READER

---



Even during the time, six years ago, when I zealously devoted myself to association with the renowned Master Michael Maestlin, I sensed how inadequate, in many respects, the usual view about the construction of the universe is. I was thus so excited by Copernicus, who my teacher mentioned quite often in his lectures, that I not only often defended his views in the disputations with the candidates, but I also authored an elaborated disputation on the thesis that the "first movement" originated with the rotation of the Earth. I also began to ascribe to the Earth the movement of the Sun, for physical, or, if it better pleases the reader, for metaphysical reasons, just as Copernicus does it for mathematical reasons. . . .

This expresses the fundamental difference between Kepler and Copernicus. Copernicus wants to reassert uniform rotational movement of the heavenly bodies, which the Ptolemaic system only pretended to preserve. Kepler takes the Sun in the center of the universe as the starting point of a new physics, and his equivalence between physics and metaphysics shows how different Kepler's notion of physics is from that of today's science. Just what is meant by that, will become evident in the excerpt below (p. 27) from Kepler's Chapter 2.



There were three things, especially, whose causes, why they are the way they are, and not differently, I incessantly researched, the *number*, *magnitude*, and *movement* of the orbits. I was led to dare this by those beautiful harmonies of things at rest; that is, the Sun, the fixed stars, and the intervening space, with God the

---

\* Dear reader, forgive the beginner his not entirely correct manner of speech. Philosophy, to be sure, seeks in the body something that is different from the human being, since the body undergoes continuous change, while the human being remains an identity. The spirit, however, is that which makes a human being human: so, the spirit is not something that is different from the human being. But what I wanted to say, remains: The spirit requires its sustenance, and that is different from the sustenance of the body, and it also has its special pleasures.

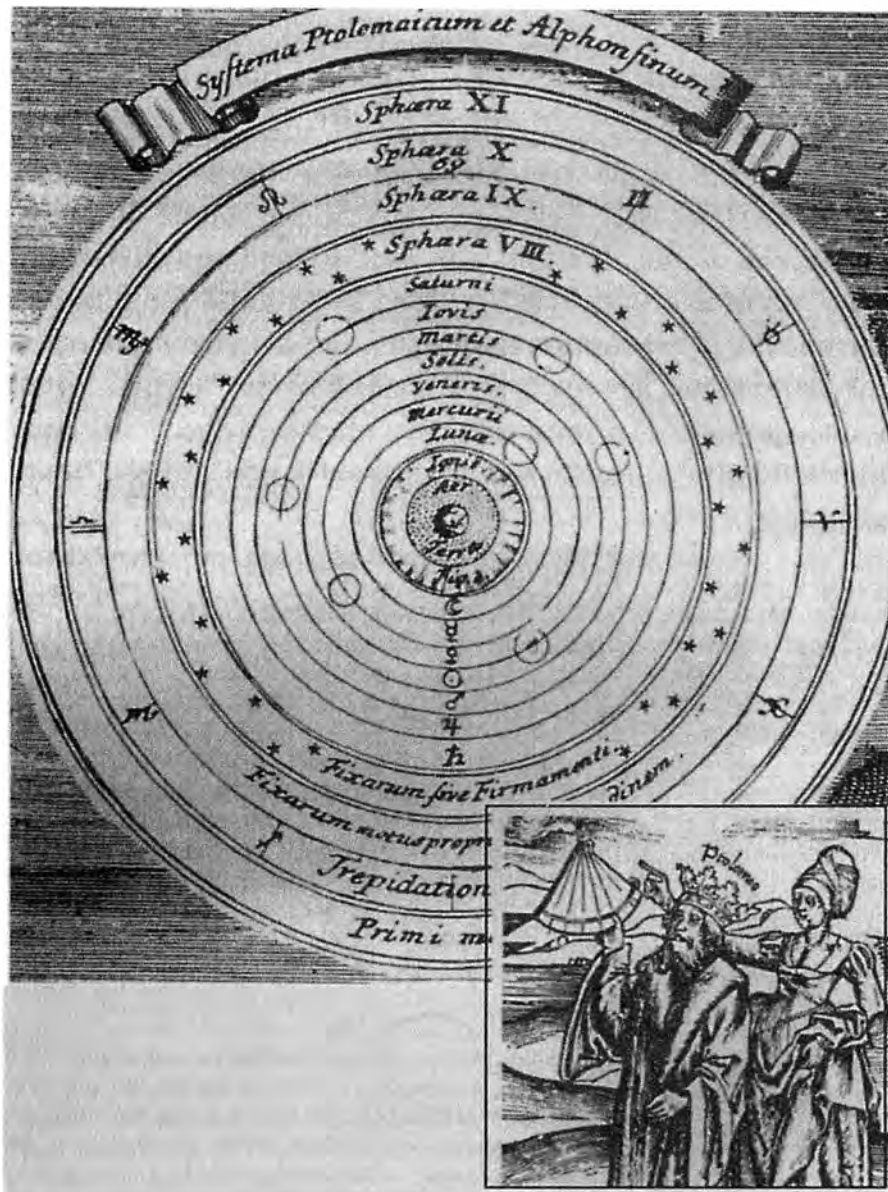

The universe of Ptolemy: Heaven and Earth were of different natures and the Earth did not move.

Father, the Son, and the Holy Spirit. . . .

I lost nearly the entire summer in this difficult work. Finally, upon an entirely unimportant occasion, I came closer to the truth. I believe it was through divine Providence that I obtained by accident that which I had been unable to obtain previously through my work; I believe this all the more, because I always prayed to God to let my plan be successful if Copernicus had proclaimed the truth. Then, on the 19th of July 1595, as I wanted to show my listeners how the great conjunctions always leap over eight points of the zodiac, and gradually transpose from one triangle to another, I drew many triangles in a circle, if one can call them so, so that the end of one always formed the beginning of the

next. Now, at the points where the sides of the triangles intersected, there emerged a small circle; for the radius of the circle inscribed in such a triangle, is half of the radius of the circumscribing circle. The ratio between the two circles looked very similar to that of Saturn and Jupiter, and the triangle is the first of the geometrical figures, just as Saturn and Jupiter are the first of the planets. At once, I tested out the distance between Mars and Jupiter with a square, and the third distance with a pentagon, and the fourth with a hexagon. Since the eye is also required for the second distance between Jupiter and Mars, I added a square to the triangle and to the pentagon. I could not stop, I wanted to try out everything.

The end of this failed attempt was at once the beginning of the last one, successfully. My idea was, that is, that I would never reach the Sun by proceeding this way, if I wanted to maintain the order among the figures, and that I would find no reason why there should be 6, rather than 20 or 100 planets. But the figures pleased me. They are truly quantities, and they are something that existed before the heavens. For quantity was created with the body at the

beginning, the heaven was created on the second day. So, I thought, if five figures can be found among the rest, and infinitely many others, for the magnitudes and the ratio of the six heavenly orbits, which Copernicus hypothesizes, figures that have the advantage over others, that they have special characteristics, then the plan would go as I wished. Now I pressed forward anew. What do figures in the plane have to do with spatial orbits? The three-dimensional bodies would have to be dealt with first. You see, dear reader, now you have my discovery and the material for the whole of the little book lying in front of you! For, if you tell that to someone, who has just a little knowledge of geometry, then the five regular solids with their

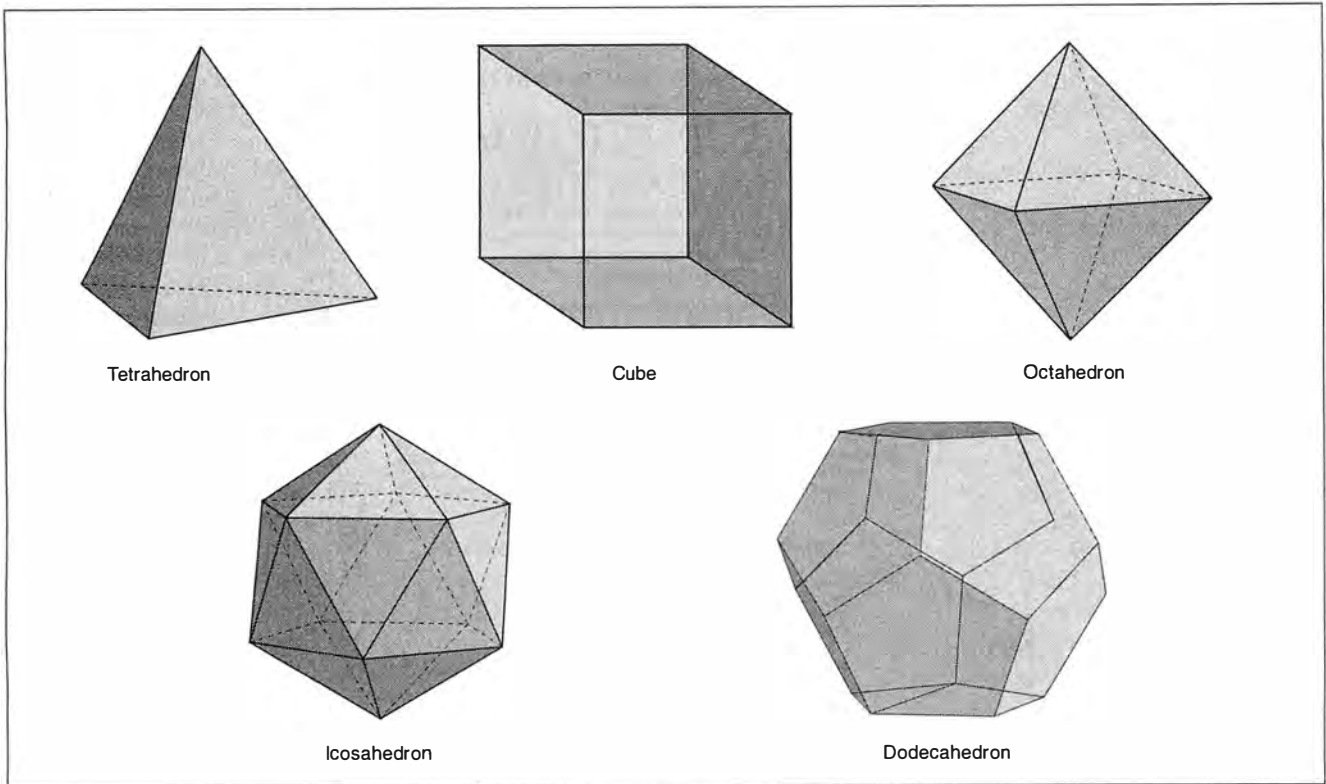

ratios to the circumscribed and inscribed circles immediately leap into his eyes; he will recall at once that famous corollary of Euclid to Postulate 18, Book 13, where it is proven that it is impossible that more than five regular solids exist, or that they be conceivable. It is amazing: although I did not yet clearly understand the ordered succession of the particular solids, yet, on the foundation of a supposition, derived from the known distances of the planets, without any confirmation, I hit my target of the ordering of the planets so successfully, that later, when I investigated the matter with specific reasons, there was nothing that I had to change.

I recall that I communicated the theorem just as it occurred to me, and in words I expressed it thus: "The orbit of the Earth is the measure for all the other orbits. A dodecahedron circumscribes it; the sphere circumscribing this is Mars. A tetrahedron circumscribes it; the sphere circumscribing this is Jupiter. A cube circumscribes the orbit of Jupiter; the sphere that circumscribes this is Saturn. Now lay an icosahedron into the orbit of the Earth; the sphere inscribed to this, is Venus. Lay an octahedron in the orbit of Venus; the sphere inscribed in this, is Mercury. There you have the reason for the number of the planets."

In his first chapter, Kepler develops the reason for the correctness of the Copernican theory and he explains it. In the second chapter, he goes on to his proof:

#### SKETCH OF MY MAIN PROOF

**I**n order now to come to my subject and to substantiate the just described theory of Copernicus about the new world, I want to go through the matter briefly from the beginning.

It was body [substance] that God created at the beginning. If we have this conception, it becomes somewhat clear why God created body at the beginning and not something else. I say that God had in His mind quantity; in order to realize it, He needed everything that belongs to the essence of body, and in this way, the quantity of body, insofar as it is body, be the form and starting point of its definition. . . .

This means: God created the world "according to Reason," so that things were created in an order of succession that is also knowable by reason.

**G**od wanted quantity to come into existence before everything else, chiefly so that a comparison of *curved* and *straight* could occur.

Nicholas of Cusa and others seem to me so divinely great just for the reason, because they esteemed the relationship of the straight and curved toward each other so highly, and dared to ascribe the curved to God and the straight to created things. Therefore, those who attempt to comprehend the



Creator through the creatures, God through human beings, divine thought through human thoughts, hardly accomplish work that is more useful than those who seek to imagine the curved through the straight, the circle through the square.

Although that alone sufficed to establish the purpose God had with the quantities and the special importance of the curved, something else came into it in addition, something far greater; that is, the image of the triune God in the area of the sphere, of the Father in the center, of the Son in the surface, of the Holy Spirit in the equality of the position between the point and the surface. For that which Cusa ascribes to the circle, and others to the space of the sphere, that is what I alone claim for the surface of the sphere. I am firmly convinced, that there is nothing curved that is more noble and more perfect than the surface of the sphere. For the sphere is more than the area of the sphere, and is mixed with the straight line, by which alone its interior is filled. The circle, however, exists only in the plane, that is, only if the sphere or the area of the sphere is cut by a plane, does a circle emerge. From that one sees that it is on account of the straight line of the diameter that many characteristics of the cube enter into the sphere and characteristics of the square enter into the circle.

But why did God, when He was decorating the world, take as his paradigm the difference between curved and straight and the noble sense of the curved? Why indeed? Well, He did that for the reason that the most perfect Architect must necessarily construct a work of supreme beauty. "For it is not, and never was possible" (as Cicero says in his book on the universe, following the *Timaeus* of Plato), "that He, who is the Best, could make anything except what is most beautiful." Since the Creator grasped in spirit the idea of the world (we speak the way humans speak, so that we humans can comprehend it), and the idea is of something already extant and, as just said, something perfect for its content, so that the form of the work to be created

likewise become perfect, it is evident, that according to these laws that God prescribes to Himself in his goodness, God could take the idea for the foundation of the world from no other thing than His own essence. How excellent and divine this is, may be considered in two respects, first, in Himself, insofar God is one in essence and threefold in the person, and then in comparison with the creatures.

This image, this idea, God wanted to stamp upon the world. That the world might become the best and most beautiful world, that it be able to take up this idea, the omniscient Creator created magnitude and conceived the quantities, whose entire essence in a certain way is encompassed in the distinction of the two conceptions of straight

and curved; and indeed, the just mentioned double form is to make God present to us. One must also not believe that such a fitting distinction ensued as an image of God accidentally, such that God had not even reflected about it, but created magnitude as body for other reasons and by reason of a different decision, and then later the comparison of the straight and the curved, and its similarity with God, happened all by itself, to a certain extent accidentally.

It is far more probable that God chose the curved and the straight right from the beginning according to his firm decision, in order to impress upon the world the divinity of the Creator; in order to make the existence of these two possible, the quantities were there, and so that the quantities could be comprehended, before all else He created body.

Now let us see how the perfect Creator applied these quantities in the construction of the world and what shows itself, according to our reflections, as His probable procedure. We want to seek this in old and new hypotheses, and award the palm to him in whose hypothesis it is found.

That the entire world is encompassed by a spherical form was already sufficiently shown by Aristotle (in the second book of "On the Heavens"), where he

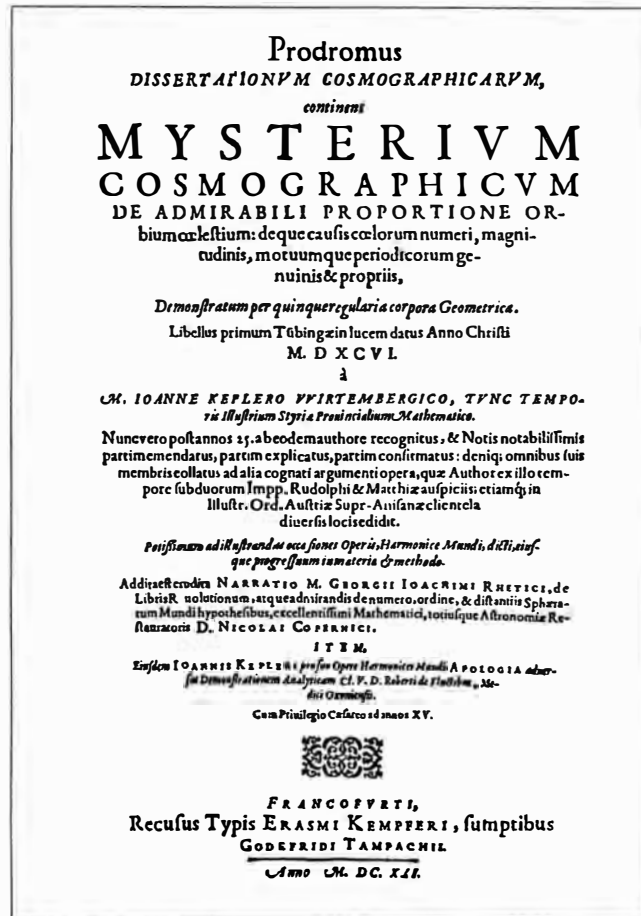

Title page from Kepler's second edition of the *Mysterium Cosmographicum*, 1621.

bases his proof, among other things, on the prominent importance of the surface of the sphere. For the same reasons, even farthest fixed stars still have this form, although no movement is ascribed to them; this form carries the Sun as the center-point in its bosom. That the other orbits are round results from the movement of rotation of the stars. That, therefore, the curved found application for the decoration of the world, requires no further proof. . . .

Kepler here is still assuming circular planetary orbits and not elliptical orbits, as he would later. It is not possible to see a fixed-star's parallax with the naked eye, and it took many decades until the telescope was sufficiently developed that the different distances of the fixed stars could be observed. Moreover, today's microwave background of the "Big Bang" corresponds conceptually to an external spherical shell of the universe, which is the sphere of the fixed stars, according to Kepler.



Although we see three kinds of quantities in the world, that is, form, number, and body, we find the curved only in the form. The content is not important, and indeed, for that reason, because a figure inscribed in a similar figure with the same center (for example, a sphere within a sphere, a circle within a circle), either touches everywhere or nowhere. That which is spherical, since it represents an absolutely unique quantity, can only be associated with the number 3. If, therefore, God had considered nothing but the curved at the creation of the world, there would be nothing in our world structure but the Sun at the center, which was the image of the Father, the sphere of the fixed stars, or the water of the Mosaic report upon the surface, which was the image of the Son, and the heavenly ether filling everything, that is, the extension and the firmament, which was the image of the Holy Spirit. But because the fixed stars exist in uncountable numbers—although the wandering stars are a determinate number, and because the magnitudes of the individual heavenly orbits are different, we must necessarily seek the cause for all of this in the concept of the straight. We must then assume that God made something in the world haphazardly, although the best and most reasonable plans are available; and no one will be able to convince me, that this plan is only valid for the fixed stars, whose positions are the least regular, as if determined by the chance fall of a seed.

Let us, therefore, now consider the straight quantities. Just as we previously chose the spherical surface because it is the most perfect quantity, we now move with *one* leap to the bodies (solids), because they are the most perfect among the straight quantities, and consist of three dimensions. That the idea of the world is perfect is established. But we want to leave the straight lines and surfaces out of the finite, best ordered, and perfectly beautiful

world, because they are infinite in number and thus unsuitable for an order.\* The bodies, of which there are an infinite times infinitely many kinds, we now want to examine, and select some of them on account of certain characteristics; I am thinking of those where there are equal edges or the angles or the sides, individually or in pairs or in some certain shared lawfulness, so that one can come to something finite with a good reason. If now one species of bodies, defined by certain conditions, indeed consists of an infinite number of kinds, but resolves into an immense multiplicity of individual bodies, then we want to use the corners and the midpoints of the sides of these bodies to represent the multiplicity, the side and position of the fixed stars, if it is possible. If, however, this surpasses the power of a human being, then we want to postpone determining the number and position of the fixed stars, until someone can tell us all of them, according to number and magnitude. For that reason, we leave the fixed stars aside, and leave them to the omniscient Architect, who alone knows the number of the stars, and calls each by its name, and we turn our view to those that are closer, which exist in fewer number, the movable stars.

If we now finally make a selection among the bodies, and push to one side the entire lot of those that are irregular, and only keep those whose sides are all equal and all of equal angles, then those five *regular solids* remain, which were given the following names by the Greeks: the *cube* or the *hexahedron*, the *pyramid* or the *tetrahedron*, the *dodecahedron*, the *icosahedron*, and the *octahedron*.†

\* Oh! That is bad. We want to leave them out of the world? Yes, in the Harmony I called them back again for reason of the right of return. Why do we want to ban them? Because they are infinite in number and completely unsuitable for an order. But it is not they that are unsuitable, but I was unsuitable, on account of my ignorance at that time, which I had in common with most to comprehend their order. Thus, in Harmony I, I made a selection among the infinitely many, and discovered the beautiful order that exists among them. For what should we ban the lines from the original image of the world, where God Himself made use of the lines in his work for its representation, that is, through the movement of the planets? The manner of expression, therefore, must be improved, in order to maintain the sense. In the establishment of the number of the heavenly bodies and of the breadth of the spheres, the lines should indeed be left aside initially; in classifying the movements, however, which occur in lines, we cannot leave the lines and surfaces to one side, which alone are the origins of the harmonic proportions.

† The prominent importance of the solids lies in their simplicity and in the equal distances of the sides from the center of the figure. For, as God is the norm and rule for the created things, so is the sphere for the solids. This, however, has the previously mentioned characteristics: (1) It is the simplest, because it is enclosed in a boundary, that is, by itself. (2) All of its points have the perfectly same distance from the center-point. Of all the solids, the regulars are the closest to the sphere in perfection. Their definition lies in the requirement that they (1) have edges, (2) sides, and (3) vertices, which are the same in kind and magnitude; therein lies the simplicity. From this definition, it follows, without further ado, that (4) the center-points of all sides are equally distant from the center-point (of the figure), (5) that the figure inscribed in a circle touches it with all the vertices, (6) that they sit firmly within it, (7) that they touch an inscribed circle with the midpoints of all the sides, (8) that the inscribed circle sits firm without movement, (9) that they have the same midpoint as the figure. That brings about another similarity with the sphere, which consists in the equality of the distances from the sides.<sup>1</sup>

For the proof that there can not be more than these five, see Euclid, Book XIII, the note following Theorem 18.\*

Because now the number of these solids is definite and very small, but the number of the remaining ones is uncountable or infinite, then there must be two species of stars in the universe also, which distinguish themselves by an evident characteristic (such as are rest and motion); the one species must border on the infinite, the other must be narrowly limited, like the number of the planets. This is not the place to discuss the reasons why these planets move but the others do not. But assuming, that the planets are in need of movement, then it follows that they must obtain circular orbits in order to maintain this movement.

Thus, we arrive at the circular orbit through movement, and at the bodies through the number of magnitude. What other choice do we have, than to say, with Plato, that God is always practicing geometry, and, in the construction of the wandering stars, he inscribed bodies in circles and circles in bodies for so long, until there was no body left that was not accompanied by movable circles within and without. From the theorems 13, 14, 15, 16, and 17 of the 13th book of Euclid, it is evident to what a high degree these solids are suited by nature for this process of inscription and circumscription. If now the five solids are embedded in each other, and spheres are added both between them and outside of them to bound them, then we obtain just the number

of six spheres.

Now, if any other age had examined the order of the world on the basis of the assumption that there are six movable orbits around the immovable Sun, this was, by all means, a result of true astronomy. *But Copernicus has, in fact, six orbits of this sort, which have proportional relationships to each other pair-wise, such that the five solids fit perfectly within them; that is the essence of the following discussion.* So, one will have to listen to Copernicus until someone poses hypotheses which agree even better with our philosophical observation, or until someone teaches, that that which has been directly gained from the principles of nature by means of the most rigorous procedure of proof, might have smuggled its way, quite by accident, both into the numbers as well as into the human spirit. For what could be more surprising, than the fact that that which Copernicus discovered in the phenomena, in the effects, *a posteriori*, just as a sculptor supports himself with his cane (as he used to say to Rheticus), more through a fortunate whim than through a reliable procedure of reasoning, and formulated, that all of that, I say, can be established and comprehended from reasons, which are derived *a priori* from causes, from the idea of the Creation?

But if someone should want to take these philosophical conclusions of reason unreasonably and reject them in mockery, for that reason that I, a novice, present them toward the time of the end of the world, while the old lights of philosophy are silent, to such a person I would introduce Pythagoras as a leader, guarantor, and guide from the most distant antiquity. I have mentioned him often in my lectures. For, since he understood the excellence of the five solids, he came to the insight 2,000 years ago, through considerations very similar to mine today, that it was not unworthy of the Creator to take consideration of them, and he ordered nonmathematical things, on account of their nature and their special accidental qualities, according to esteemed mathematical things. The Earth he equated to a cube because both are stable, which is a quality not only of the cube. The heavens he assigned to the icosahedron, because both can rotate. He assigned the pyramid to fire, because these have the form of a flickering flame; the other two solids he distributed between air and water, because in both cases, the one part is related to the other. But Pythagoras had no Copernicus who might have told him first of all what exists in the universe. Starting from that, he would doubtless have found out why it is so, and this arrangement of the heavenly orbits would be as well known today as the five solids themselves, and would be as accepted as was the case, in the past, with the belief in the movement of the Sun and the immobility of the Earth.

But let us investigate further, whether the proportions of the five solids prevail between the orbits of Copernicus. First of all, we shall make a

\* That note reads as follows<sup>2</sup>: There can be no other solids in addition to the five named, enclosed by equally sided and equally angled sides. For no figure can be formed from two triangles or two other figures.

From three triangles, however, there ensue the vertices of the pyramid, out of four those of the octahedron, out of five those of the icosahedron.

From six equally sided and equally angled triangles, which come together at a point, no solid vertex can be formed. For since the angle of the equally sided triangle is 2/3 of a right-angle, six such angles taken together are four right angles. And that is impossible. For the entire solid vertex is formed from less than four right angles (Euclid Book XI, Theorem 21).

For the same reason, no solid vertex can be formed out of more than six such angles.

The vertices of the cube ensue from three squares; from four squares there ensues no solid vertex, for its angles, taken together, are four right-angles.

The vertices of the dodecahedron ensue from three equally sided and equally angled pentagons. But no solid vertex ensues from four of them. For since the angle of the equally angled pentagon is one 1/5th of a right angle, four such angles would be larger than four right angles. And that is impossible. Solid vertices also cannot be formed by other polygons, because that would result in something impossible. It is, therefore, clear, that no other solids can be formed than the named five, which are enclosed by equally sided and equally angled sides. Therefore:

	Type of face	No. of faces	No. of edges	No. of vertices	Inscribed sphere
Cube	Quadrilateral	6	12	8	Medium
Octahedron	Triangle	8	12	6	Equal to cube
Dodecahedron	Pentagon	12	30	20	Largest
Icosahedron	Triangle	20	30	12	Equal to dodecahedron
Tetrahedron	Triangle	4	6	4	Smallest



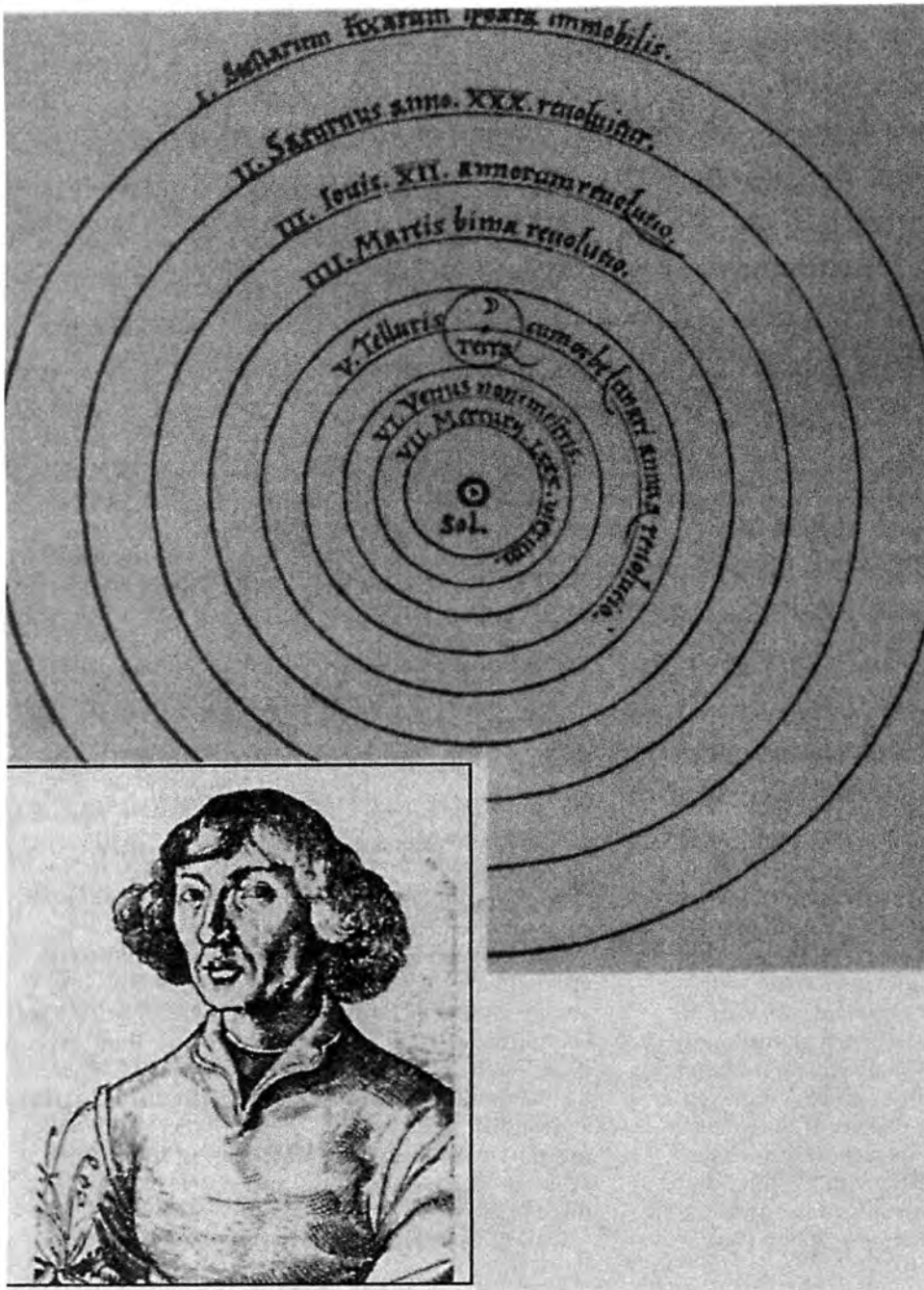

The Copernican system, in which the Sun has been put at the center of the universe. Copernicus's theory was an important point of departure for Kepler's revolutionary discoveries.

rough estimate. According to Copernicus, the largest difference in distance exists between Jupiter and Mars, as may be seen in the representation of the hypotheses in Figure 1 [not shown] and further below in chapters 14 and 15. The distance of Mars from the Sun is not even a third of the distance from Jupiter. We must therefore seek that solid for which the difference between the circumscribed and inscribed sphere is the largest (permit me to use the hollow solid rather than the firm solid); this is the tetrahedron or the pyramid. The distances of Jupiter

magnitudes result precisely in this number of proportions. . . .

CHAPTER 13  
ON THE CALCULATION OF THE SPHERES INSCRIBING  
AND CIRCUMSCRIBING THE SOLIDS

**O**ur discussion thus far serves only to support the theorem we have posited with reasons of probability. Now we want to move to the determination of the astronomical orbits

and Saturn represent the second largest difference. The first is only a little more than the half of the latter. A similar difference occurs in the interior and exterior circle of the cube. Saturn thus circumscribes the cube, while the cube circumscribes Jupiter.

Nearly the same proportion prevails between Venus and Mercury; it is not dissimilar to the proportions of the circles of the octahedron. Venus circumscribes this solid, while Mercury is circumscribed by it.

The two remaining proportions between Venus and the Earth, as well as between these and Mars, are the smallest and are nearly identical to each other; the interior orbit is three quarters or two thirds of the exterior. In the icosahedron and the dodecahedron, the proportions of the distances of the two spheres are likewise identical, and here they are in fact the smallest among the regular solids. It is therefore probable that the distance of Mars from the Earth is determined by the others. Thus, if I am asked, why there are only six movable orbits, then I shall answer: because there cannot be more than five proportions, so many, that is, as there are regular solids in mathematics. But six

**Table 1**  
**PROPORTIONS OF CIRCUMSCRIBING AND INSCRIBING SPHERES TO THE FIVE SOLIDS**

	Radius of the circumscribing sphere	Length of the edge	Radius of the circle circumscribing a face	Radius of the inscribed sphere
Cube	1,000	1,115	816½	577
Tetrahedron	1,000	1,633	943	333
Dodecahedron	1,000	714	607	795
Icosahedron	1,000	1,051	607	795
Octahedron	1,000	1,414	816½	577*

\* [Kepler's note on the table]: By the way, the radius of the circle inscribed in the octahedral square is 707.

and to geometrical investigations. If these investigations do not agree, then all of our effort has been in vain. First of all, we want to see in what proportions the spheres, inscribed and circumscribing, stand to the five solids.

Kepler now calculates the values in Table 1, which is the basis for the calculation and the comparison with the distances as Copernicus had determined them.

CHAPTER 14

**THE CHIEF PURPOSE OF THE BOOK; THE  
ASTRONOMICAL PROOF, THAT THE FIVE SOLIDS LIE  
IN BETWEEN THE HEAVENLY ORBITS**

. . . Since I have taken it upon myself, at the beginning of my work, to derive from the five solids the reason why the omnipotent Creator always left just so much space between two planets, and to show that the individual solid figures determine the spaces in between, in succession, we now want to see with what success this book shall be crowned; we want to bring the issue before the judge's bench of astronomy for judgment, and Copernicus shall explain it to us. I shall let the orbits themselves be as thick as required by the rising and setting of the planets. If the solids are so arranged as I have said, then the interior side of a sphere above it must coincide with the sphere surrounding a solid, the exterior side of the next sphere must coincide with the interior sphere; but

the solids must be taken in the order of succession as I established above, for inherent reasons.

Kepler compares the values he found in the previous chapter with the distances of Copernicus, and obtains the approximation in Table 2.

Kepler continues:

If one adds the lunar system to the thickness of the Earth orbit, and lets 1,000 units be the standard for the interior of the orbit of the Earth and the Moon, then the exterior of the orbit of Venus is 847, according to Copernicus. The exterior of the Earth's orbit with the Moon is 801, if the interior of the orbit of Mars is 1,000. Please refer time and again to the chart preceding this discussion [Table 1], where I have represented the embedding of the solids.

And now see how the corresponding numbers approximate each other. For Mars and Venus, they are the same. For Earth and Mercury, they are not so very different from one another; only for Jupiter do they diverge greatly, but, at that immense distance, no one should be surprised at this. One also sees what a great difference the small circle of the Moon makes for Mars and Venus, if the thickness of the Earth's orbit is added, although this little circle has hardly three parts, while the Earth's orbit is 60.

It is evident from this how easily one would have

**Table 2**  
**KEPLER'S ORBITAL DISTANCES COMPARED WITH THOSE OF COPERNICUS**

	Radius of the interior sphere	Sphere of the planet beneath it	Orbital distance according to Copernicus	Chapter no.*
Saturn	1,000			
Jupiter	1,000	577	635	9
Mars	1,000	333	333	14
Earth	1,000	795	757	19
Venus	1,000	795	794	21 and 22
Mercury	1,000	577 or 707	723	27

\* in Book V of Copernicus

noticed, and what great discord in the numbers had occurred, if our experiment had turned against the nature of the heaven; that is, if God Himself had not taken account of these proportions when He created the Universe. . . .

CHAPTER 15

THE IMPROVEMENT OF THE DISTANCES AND THE DIFFERENCE OF THE PROSTHAPHERESES

The prosthapheresis is the angle which an orbit of an interior planet passes over when viewed from a certain point on the orbit of an exterior planet. In the *Mysterium Cosmographicum*, Kepler develops a precise table of his model in comparison to the Copernican distances. Table 3 is derived from Kepler's table. All magnitudes are given in astronomical units (A.U.); that is, where the distance from the Earth to the Sun is 1. The higher value is the maximum orbital distance of the planet from the midpoint of the Sun; the lower is the minimal value. Column 1 gives the values calculated on the basis of the Prutenic Tables according to the Copernican system. Column 2 shows the results from Kepler's model of the five Platonic solids. Column 3 gives the values accepted today. Column 4 shows the difference between Kepler's model and the Copernican values, and column 5 shows the difference from today's accepted values.

The numbers in Kepler's model represent the thickness of the spherical shell within which the orbits of the planets lie, where he takes the distance of the Moon (the Earth's Moon was the only known Moon in the solar system at that time) for the thickness of the Earth's orbit, and not the difference between the perihelion and aphelion.

The largest divergences result with respect to the Earth, which is understandable, because Kepler's Earth orbit was conceptually somewhat different from what Copernicus or today's measurements understand by the Earth's orbit. Kepler's orbit would actually have to be called the Earth-Moon orbit.

Kepler's values for Jupiter and Saturn are even closer to today's values than the Copernican values, but, for the interior planets, only the aphelion of Mercury agrees exactly. Kepler was well aware of the discrepancies between his model and the Copernican values.

CHAPTER 23

ON THE ASTRONOMICAL BEGINNING AND THE ASTRONOMICAL END OF THE WORLD, AND ON THE PLATONIC YEAR

In this last chapter, Kepler ends his work with the following poem. Not wishing to deprive the reader of its simple beauty, it is here reprinted in full.<sup>3</sup>

**G**reat God, Creator of the Universe,  
 And our eternal power, how great thy fame  
 In every corner of the whole wide world!  
 How great thy glory, which flies wondrously  
 Above the far-flung ramparts of the heavens  
 With rushing wings! The babe salutes it, spurning  
 The breast, replete, and with his halting lips  
 Bears powerful witness—witness which confounds

The haughty enemy, who shows contempt  
 For thee, and shows contempt for law and justice.  
 Yet, to believe thy Godhead is within  
 This spacious sphere, let me look up astonished  
 At thy achievement of this mighty heaven.  
 The work of the great Craftsman, miracles  
 Of thy strong hand; see how thou hast marked out  
 The five-fold pattern of the starry spheres.  
 Dispensing light and spirit from their midst;  
 See by what law thou dost control the reins  
 Of their eternal course; see how the Moon  
 Varies her path, her toils, how many stars  
 Thy hand has scattered over that boundless field.  
 Great Builder of the Universe, what plea  
 Of the poor, humble, small inhabitant  
 Of this so tiny plot compelled thy care  
 For his harsh troubles? Yet thou dost look down  
 On his unworthiness, carry him up  
 On high, a little lower than the Gods,  
 Bestow great honors on him, crown his head  
 Nobly with diadem, appoint him king  
 Over the tokens of thy handiwork.  
 Thou makest all that is above his head,  
 The great spheres with their motions, bow before  
 His genius. All creatures of the Earth,  
 The herds bred for his works, and fitted for  
 The smoking altars, and the generation  
 Of wild beasts, which remain to dwell in woods,

Table 3  
 KEPLER'S MODEL OF THE ORBITS  
 COMPARED WITH THAT OF COPERNICUS

(all figures are in A.U.)

*The largest deviations of the two models arise in the case of the Earth. The significance of this, however, is that Kepler's Earth orbit is conceptually different from what Copernicus and today's measurements understand by Earth orbit. Kepler's orbit would properly have to be called the Earth-Moon orbit. For Jupiter and Saturn, Kepler was even closer to today's values than the Copernican values, while for the inner planets only the aphelion of Mercury agrees exactly. Kepler was aware of the discrepancies between his model and the Copernican values.*

Column no.	1	2	3	4	5
Saturn	9.99	11.30	10.07	+1.31	+0.23
	8.34	9.44	9.01	+1.10	+0.43
Jupiter	5.49	5.45	5.45	-0.04	0.00
	5.00	4.96	4.95	-0.04	-0.01
Mars	1.65	1.65	1.67	0.00	-0.02
	1.39	1.40	1.38	+0.01	+0.02
Earth	1.04	1.10	1.02	+0.06	+0.08
	0.96	0.90	0.98	-0.06	-0.08
Venus	0.74	0.71	0.73	-0.03	-0.02
	0.70	0.67	0.72	-0.03	-0.05
Mercury	0.49	0.47	0.47	-0.02	0.00
	0.23	0.22	0.31	-0.01	-0.09

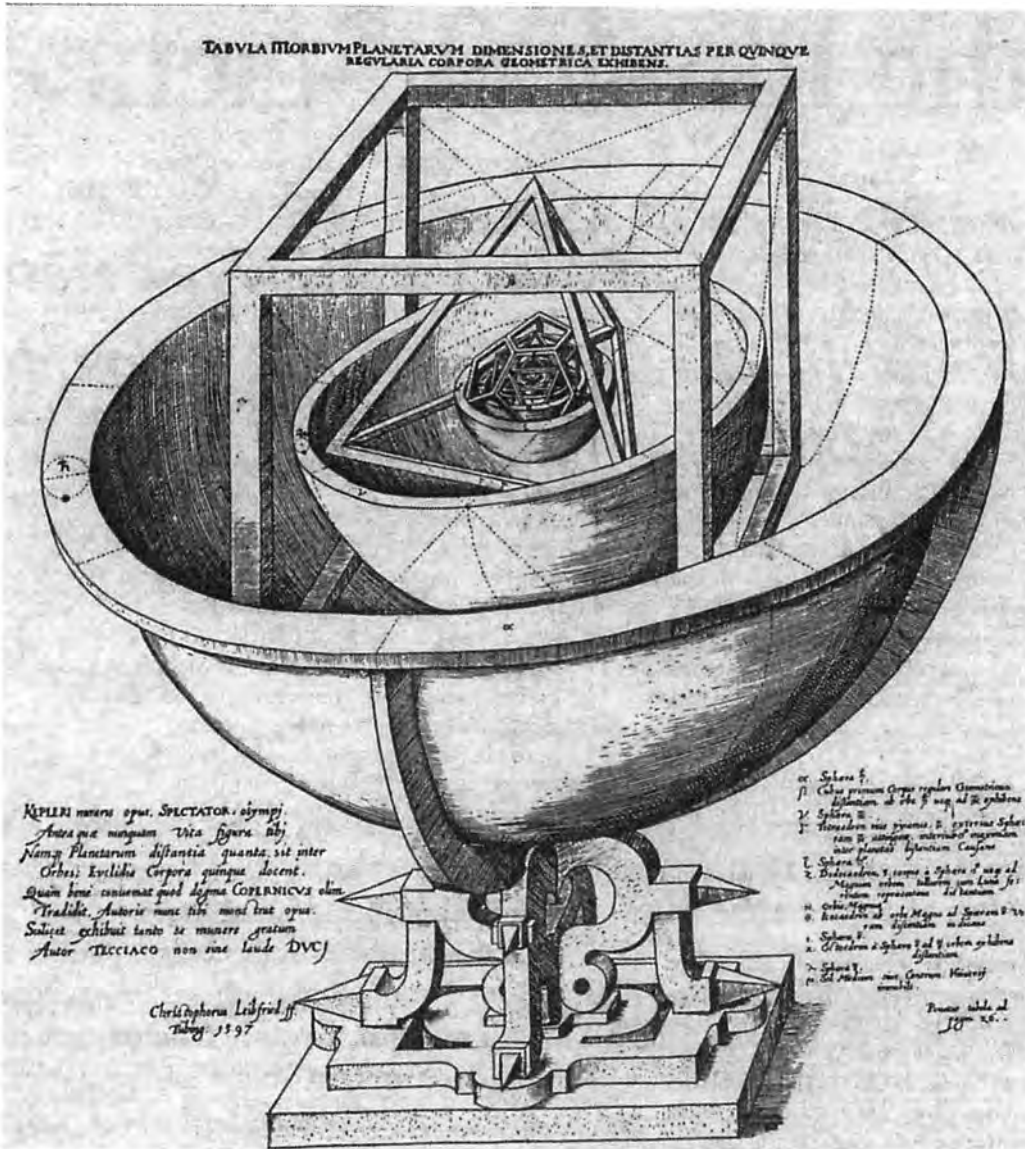

Kepler's model of the universe, a copper engraving from the first edition of *Mysterium Cosmographicum* in 1596. The five Platonic solids are in harmony with the planetary spheres.

The birds, which with light feathers strike the air,  
 The fish, which swim through rivers and through seas,  
 Over all these by thy command he rules  
 By his dominion and his strong right hand.

Great God, Creator of the Universe,  
 And our eternal power, how great thy fame  
 In every corner of the whole wide world!

### The *Mysterium* and Kepler's Life's Work

In conclusion, we ask how Kepler's first work is to be understood in the context of his life's work in general. Thorough historians do point out how much Kepler's ideas are supposed to have developed over the course of his life. The shift to elliptical orbits, especially, in contrast to the circular orbits about which Kepler speaks in the *Mysterium*, is taken to prove, that Kepler was still bound to "Aristotelian" thinking. Attention is also called to the fact that in the *World Harmony*, Kepler

makes a claim for the harmonic relationships seen from the standpoint of the Sun, between the angular velocities at extreme points of the orbits (that is, aphelion and perihelion) of the planets, which supposedly means that he gave up the hypothesis of the *Mysterium*.

Kepler delivered an appropriate answer to all of these academic arguments: Two decades after the publication of his first work, Kepler reprinted it *completely unchanged*, merely adding a few footnotes.

That which no formalist understands is quite simple for Kepler's creative thinking. There is no contradiction between the *Mysterium* and the *World Harmony*, because the harmony they both describe is a process. Kepler says that he set out to discover the harmony of a crystal in the *Mysterium*, and then, in the *World Harmony*, he found one in fact that is living. Both models correspond to the nature of the solar system, and both remain true, despite their formal differences.

Neither of them is a "model" in today's sense of the term; each is a different expression of the universal process of the development of nature. We see these harmonies, because they carry the process of life, like a "little flag," just as does the visible Golden Section in the five petals of a flower.

Until his death, Kepler always looked upon the *Mysterium Cosmographicum* as the cornerstone of all of his work because it expressed the character of his thinking and the character of the physical lawfulness of nature. In this sense, Kepler says in his work *Tertius Interuenies*: "It is thus one of my ideas, whether all of nature and all heavenly adornment is not symbolized in geometry." For, after all, he says, "As God played the Creator, He also taught nature to play as His image, and, indeed, the very game which He played."

### Author's Notes

1. This note was included in the first edition.
2. This note was included in the first edition.
3. The English is reprinted with permission from A.M. Duncan's translation of the *Mysterium Cosmographicum* (New York: Abaris Books, 1981), p. 225.





Illustration by Pam Emerson

# FIRST ENGLISH TRANSLATION **Riemann's Philosophical Fragments**

## FOREWORD

<b>Riemann Refutes Euler</b>	36
by Lyndon H. LaRouche, Jr.	

## TRANSLATION

<b>Philosophical Fragments</b>	50
by Bernhard Riemann	

Introduction to the Second German Edition by Heinrich Weber	50
--	----

Translator's Note	50
-------------------	----

I. On Psychology and Metaphysics	51
----------------------------------	----

II. Epistemological Issues	55
----------------------------	----

III. Natural Philosophy	57
-------------------------	----

## SUPPLEMENTARY MATERIAL

On the Hypotheses Which Lie at the Foundations of Geometry [excerpts] by Bernhard Riemann	44
---	----

Riemann in English Translation	47
--------------------------------	----

Euler's Lying Attack on Leibniz	48
---------------------------------	----

Herbart on the Thought Process	52
--------------------------------	----

# Riemann Refutes Euler



Library of Congress

Bernhard Riemann (1826-1866)



Library of Congress

Leonhard Euler (1707-1783)

by Lyndon H. LaRouche, Jr.

In the following pages, *21st Century* presents the first known publication in English translation, of a group of posthumously published early writings of the famous physicist Bernhard Riemann (1826-1866).<sup>1</sup> These have the special significance of providing some relatively indispensable background for understanding how Riemann came to develop his earthshaking discoveries of 1853-1854.<sup>2</sup>

The special relevance of these pieces, pertains to the fact, that there can be no competent appraisal of Riemann's work, which does not treat his writings as, like those of Karl Weierstrass, a devastating refutation of Leonhard Euler's savage attacks on Gottfried Leibniz.<sup>3</sup> The formal issue is the question, cloaked in a discussion of mathematical series, whether or not mathematical discontinuities exist.<sup>4</sup> The relevant substantive issue behind these attacks on Leibniz by the 18th century Newtonians, Dr. Samuel Clarke and Leonard Euler, is, much more today than during Riemann's time, whether physics is a branch of mathematics, or mathematics a branch of physics.

As in the concluding sentence of his famous 1854 habilitation dissertation, Riemann demonstrated that, to settle the underlying issues of mathematics, one must depart that do-

main, into physics.<sup>5</sup> That statement plants Riemann, like his sponsor Karl Gauss before him, fully within the domain of physics, rather than the virtual reality which one associates with the influence of Bertrand Russell and the Bourbaki *golem* upon much of today's teaching of mathematics. The posthumously published papers presented in English translation here, bear directly on Riemann's development of his approach to that issue.

## Riemann and Economics

*21st Century's* attention to Riemann reflects my own original work in a branch of physical science founded by Leibniz, known as *physical economy*. My discoveries in this field supplied the principal impetus for the mid-1970s founding of the Fusion Energy Foundation, which ricocheted into the later founding of *21st Century* magazine. Although the principal part of my discoveries were not prompted by Riemann's work, the approach adopted for solving the mathematical problems posed by those discoveries was prompted almost entirely by Riemann's habilitation dissertation, leading to the designation of "LaRouche-Riemann Method."<sup>6</sup>

To introduce Riemann's posthumously published papers, I indicate the features of his dissertation which are most relevant to the problems of physical economy. To that end, consider, first, the place which mathematical discontinuities occupy in Riemann's discovery, and then, the significance of Riemann's emphasis on what he terms *Geistesmassen* in the posthumously published papers.

First, to define the significance of mathematical discontinuities, I restate Riemann's point of departure in his dissertation in my own words.

The origin of modern mathematics lies in what is commonly identified as a "Euclidean" notion of simple space-time. This idea of space-time pretends to represent the real universe, which it does not represent. It is an idea which is not a creation of the senses, but, rather, of the naive imagination. We merely imagine that space is defined by three senses of direction (backward-forward, up-down, side-to-side), and imagine that these might be extended without limit, and in perfectly uninterrupted continuity. We imagine that time is a single, limitless dimension of perfect continuity: backward-forward. Taken together, these presumptions of the imagination define a four-dimensional space-time manifold, or, in other words, a quadruply extended space-time manifold.

The naive imagination attempts to locate perceptible bodies and their motions within such a quadruply extended manifold. It may be said fairly, that our imaginary space-time manifold is used as a kind of mental mirror, upon which we attempt to project reflections of motion of bodies in space-time. The result of such projections is a simple "Euclidean" sort of algebraic mathematics, which, we soon discover, is not a mathematics of the real universe.

Classical experiments, typified by the measurement of the curvature of the Earth's surface by the ancient Eratosthenes of Plato's Academy at Athens,<sup>7</sup> supply measurable demonstration that the motion of bodies in physical space-time does not correspond to what a naive, algebraic notion of space-time

suggests. We must add non-space-time "dimensions," such as the notions of "mass," "charge," and so forth, to derive a mathematics which agrees with our measurement of the motions which are reflected, from physical space-time, upon that imaginary mirror known as simple space-time.<sup>8</sup>

Thus, in place of a four-dimensional space-time of the imagination, the attempt to explore physical space-time presents us with a physical-space-time manifold of many more dimensions than the four dimensions of naive space-time. We call these added factors "dimensions," because they can be scaled, according to the ordering-principle of "greater than" and "less than," as we do the dimensions of naive space-time. Instead of saying  $n + 4$  dimensions, we include the four in our count of  $n$ ; we speak, thus, of a "physical-space-time manifold of  $n$  dimensions." Then, commonly, we attempt to portray motion within that physical-space-time, of  $n$  dimensions, in terms of its imaginary reflection upon a four-fold space-time.

In each case, the addition of a validatable new "dimension" to the physical-space-time manifold of reference, corresponds to a change in measurement, a change in the yardstick we must employ to measure the relevant motion, or analogous form of action. For example, Eratosthenes estimated that the Earth was a spheroid of about 7,850 miles, from pole to pole (not a bad estimate for the time).<sup>9</sup> This meant, that to measure motion along the surface of the Earth, we must use a yardstick of spherical trigonometry, rather than one appropriate to a simple Euclidean plane. Similarly, once Ole Rømer had demonstrated, in 1676, that the radiation of light was governed by a principle of retarded potential, Christiaan Huygens, in 1677, generalized principles of reflection and refraction accordingly,<sup>10</sup> and, Jean Bernoulli and Leibniz demonstrated that the mathematics of the transcendental domain's special relativity must supersede the algebraic methods of Galileo, Descartes, and Newton.<sup>11</sup>

The validation of the necessary addition of such an added

1. See *Bernhard Riemann's Gesammelte Mathematische Werke*, Heinrich Weber, ed. (New York: Dover Publications reprint, 1953), "Fragmente philosophischen Inhalts," pp. 507-538. A more recent reprint of the same, Heinrich Weber's second edition (Stuttgart: B.G. Teubner, 1902), is Vaduz, Liechtenstein: Saendig Reprint Verlag Hans R. Wohlwend. Hereinafter, this is identified as *Riemann Werke*.

2. See Bernhard Riemann, "Über die Hypothesen, welche der Geometrie zu Grunde liegen" ("On the Hypotheses Which Underlie Geometry"), *Riemann Werke*, pp. 272-287. This is the famous June 10, 1854, habilitation dissertation, to which Albert Einstein referred, in identifying Riemann's work as a root of General Relativity. On the dating of the work embodied in this dissertation, 1853-1854, see H. Weber's reference to Riemann's note, which dates the discovery underlying the paper to "March 1, 1853": *Werke*, p. 508.

3. On Euler's attack on Leibniz, see Lyndon H. LaRouche, Jr., *The Science of Christian Economy* (Washington: Schiller Institute, 1991), Appendix XI, "Euler's Fallacies on the Subjects of Infinite Divisibility and Leibniz's Monads," pp. 407-425. That appendix includes the sections of Euler's *Letters to a German Princess* (dated by him May 5, 1761) in which his second explicit attack on Leibniz is made. The first occurred as his role in the scandalous case of Pierre-Louis Maupertuis, whose exposed fraud on the subject of "least action" led to Maupertuis's 1753 ouster from direction of the Berlin Academy; Euler was the principal accomplice of Maupertuis in perpetrating that hoax. We emphasize the primary coincidence between Riemann and Weierstrass here, not their secondary differences in approach.

4. See the Leibniz-Clarke correspondence on the subject of the relationship between infinite series and the differential calculus. (G.W. Leibniz, *Philosophical Papers and Letters*, edited by Leroy E. Loemker, 2nd edition [Dordrecht: D. Reidel, 1969, reprinted Boston: Kluwer Academic, 1989], pp. 675-721.) Although Leibniz's development of the differential calculus had roots in some of his earlier activities, the archival evidence is, that

what became known as Leibniz's calculus was actually developed during 1672-1676, in Paris, at Jean-Baptiste Colbert's Royal Academy of Science. Leibniz's first paper, presenting the discovery, was submitted for publication, in Paris, in 1676, immediately prior to his return to Germany. Isaac Newton's international reputation, and the Newton-Clarke attack on Leibniz, was created by Venice's Paris-based Abbot Antonio Conti (1677-1749), who sponsored a network of salons throughout Europe, a network devoted to the principal mission of seeking to discredit Leibniz, and build up Newton's reputation. Dr. Samuel Clarke was an agent of Conti, as were the Berlin circles of Maupertuis and Euler.

5. "Es führt dies hinüber in das Gebiet einer andern Wissenschaft, in das Gebiet der Physik, welches wohl die Natur der heutigen Veranlassung nicht zu betreten erlaubt." ("This leads into the domain of another science, the realm of physics, which the nature of today's occasion does not permit us to enter.") Habilitation dissertation, *Riemann Werke*, p. 286.

6. See Lyndon H. LaRouche, Jr., "Why Most Nobel Prize Economists are Quacks," *Executive Intelligence Review*, July 28, 1995, and Lyndon H. LaRouche, Jr., "Non-Newtonian Mathematics for Economists," *Executive Intelligence Review*, Aug. 11, 1995.

7. See "How Eratosthenes Measured the Unseen" (Figure 2), in Lyndon H. LaRouche, Jr., "Kenneth Arrow Runs Out of Ideas, But Not Words," *21st Century*, Fall 1995, p. 34-53.

8. This image is an accurate representation of the intent of Plato's reference to shadows which reality casts upon the imagination, as if these shadows were reflections on the wall of a cave's firelit interior.

9. *Greek Mathematical Works*, 1980. Ivor Thomas, trans., 2 vols. (Cambridge, Mass.: Harvard University Press), Vol. II, p. 273, note c.

10. Christiaan Huygens, *A Treatise on Light* (New York: Dover Publications reprint, 1962).

11. The "brachystochrone problem": Jean Bernoulli (1696). The equivalence of least time to least action.

physical dimension, by measurement, implies the challenge to be considered here. Each such addition signifies, that instead of an  $n$ -fold physical-space-time manifold,  $n$  is superseded by  $(n+1)$ . This gives us a generalized term of topology, which we might express symbolically by  $(n+1)/n$ . The series of changes, from  $n$  to  $n+1$  dimensions, is associated with a series of changes in the choice of the yardstick which we must employ to measure the relevant physical action.<sup>12</sup>

This is also the problem which confronts us, in physical economy, as one may attempt to define the correspondence between scientific and technological progress, on the one side, and, on the other side, a general, resulting increase in the productive powers of labor, per capita, per household, and per square kilometer. For that case, the type of yardstick used is termed *potential relative population-density*; that yardstick changes its scale (per capita, per square kilometer) as the level of applied scientific and technological progress advances.

### Science and Metaphor

All of the issues posed by Riemann's habilitation dissertation, while most profound, are so elementary that they might be understood at the level of a good secondary school's graduate. Once we accept his intention in that location, that paper is among the most lucid pieces of prose ever supplied to the literature of fundamental scientific discoveries. Admittedly, most of the classroom's putatively authoritative commentators have conveyed a contrary, confused view of this work. The failure of all such commentaries examined, is that the commentators, by refusing to accept the fact of what Riemann is saying, project upon him an intention which is axiomatically contrary to his own.

The axiomatic failures of such authoritative commentators occur on two levels.

Closer to the surface, they have sought to defend such post-1815 authorities in taught mathematics as Newton, Euler, Augustin Cauchy, et al., from the devastating refutation provided by Riemann's discovery. This centers around Euler's argument against Leibniz. That relatively more superficial axiomatic assertion, is the hysterical insistence of the positivists, that, ultimately, mathematical discontinuities do not exist.<sup>13</sup>

On the deeper level, there is a more devastating issue, which the opponents of Leibniz and Riemann refuse to debate.

The radical positivists of the Bourbaki cult exemplify this deeper issue. The peculiar, Ockhamite deism of such positivist ideologues, is the dogma, that all questions of science must be settled by mathematical proofs delivered upon a blackboard, or, by a modern digital-computer system. Every demonstration that mathematical formalism is not the god of

science, whether by Plato and his academy after him, or from moderns such as Leibniz or Riemann, fills such positivists with an obscene, irrationalist rage, akin in spirit and rationality to that of Marat's or Danton's Jacobin mob.

This deeper of the two levels of axiomatic issues, underlies the assignment of Abbot Antonio Conti's agent, Dr. Samuel Clarke, for the attacks upon Leibniz. This is the issue underlying the savage, posthumous attacks upon Leibniz by the Conti salon's Euler. This was also the basis for the hyena-like attack, led by the devotees of Ernst Mach, upon Max Planck, during the period of World War I.<sup>14</sup>

Once we acknowledge the primary historical fact of mathematical-physical knowledge, that each of those discoveries of physical principle which is validated by the appropriate measurement, presents mathematics with a topological challenge of the indicated  $(n+1)/n$  form, mathematical formalism is stripped of that attributed, god-like authority which the devotees of Euler and the Bourbaki cult defend so fanatically.<sup>15</sup> Like Leibniz before him, Riemann's discovery demonstrates that formal mathematical-physics schemes do not embody the potentiality of a truth-doctrine. To find truth, we must depart the domain of mathematics, and go over into another domain, the realm of experimental physics.

---

**“Like Leibniz before him, Riemann's discovery demonstrates that formal mathematical-physics schemes do not embody the potentiality of a truth-doctrine. To find truth, we must depart the domain of mathematics, and go over into another domain, the realm of experimental physics.”**

---

The key to all among these, and derived formal issues of mathematical physics, is the connection between the erroneous insistence, that, ultimately, no discontinuities exist in mathematics, and the deeper assumption (also false), as among the followers of the Bourbaki dogma, that mathematics can be a truth-doctrine.

It is admissible to state, that any consistent mathematical physics of a specific,  $n$ -fold physical-space-time manifold, can be read as if it were a formal, deductive theorem-lattice. In this interpretation, it appears that every theorem of that lattice has the qualifying attribute of being a proposition which has been shown to be not-inconsistent with whatever set of axioms and postulates underlie that lattice in its entirety.<sup>16</sup> Such a set of axioms and postulates is identified by both Plato

12. This does not justify the presumptions of some popularized notions of a differential geometry. The basis for that word of warning will be made clearer below.

13. Formally, Euler's assertion was a defense of the purely arbitrary assumption of the naive Euclidean imagination, that linear extension is perfectly continuous without limit. Since Euler's supposed proof of that assertion depends absolutely upon the assertion of that axiom which it purports to prove, Euler's famous tautology proves nothing at all. Euler's folly on this point is the hereditary origin, via Lagrange and Laplace, of Cauchy's bowdlerization of Gottfried Leibniz's version of a calculus.

14. That attack upon Planck, first from within the German-speaking scientific community of the World War I interval, was continued in the savagery of

Niels Bohr and other accomplices of Bertrand Russell, during the period of the famous 1920's Solvay Conference sessions.

15. This is literally an ancient issue. This topological challenge is the same ontological paradox, of the "One" and "Many," posed by Plato's *Parmenides*.

16. For example: What Euler defends, by means of a rather silly tautology, in his 1761 attack upon Leibniz, is the naive, Euclidean, axiomatic assumption of the perfect persistence of linearization indefinitely, into the very large and very small.

17. *Riemann Werke*, p. 525: "Das Wort Hypothese hat jetzt eine etwas andere Bedeutung als bei Newton. Man pflegt jetzt unter Hypothese Alles zu Erscheinungen Hinzugedachte zu verstehen."



### HOW ERATOSTHENES 'MEASURED' THE EARTH'S CIRCUMFERENCE

Eratosthenes, a member of the Platonic Academy in Athens and the head of the library at Alexandria in the third century B.C., devised a method of measuring the curvature of the Earth without seeing what he was measuring—but “seeing” an anomaly in sense perception. His method focussed on the difference found between the shadows cast on two identical sundials at different latitudes at the same hour.

At noon on the day of the summer solstice, two hemispherical sundials were placed, one at Alexandria and the other at Syene (Aswan) in Egypt. The gnomon in the center of each sundial pointed to the center of the Earth. The gnomon cast no shadow at Syene, but it cast a shadow of  $7.2^\circ$  at Alexandria. By knowing the distance between the two cities (about 490 miles), Eratosthenes calculated the Earth's circumference to be about 24,500 miles, which is accurate to about 50 miles.

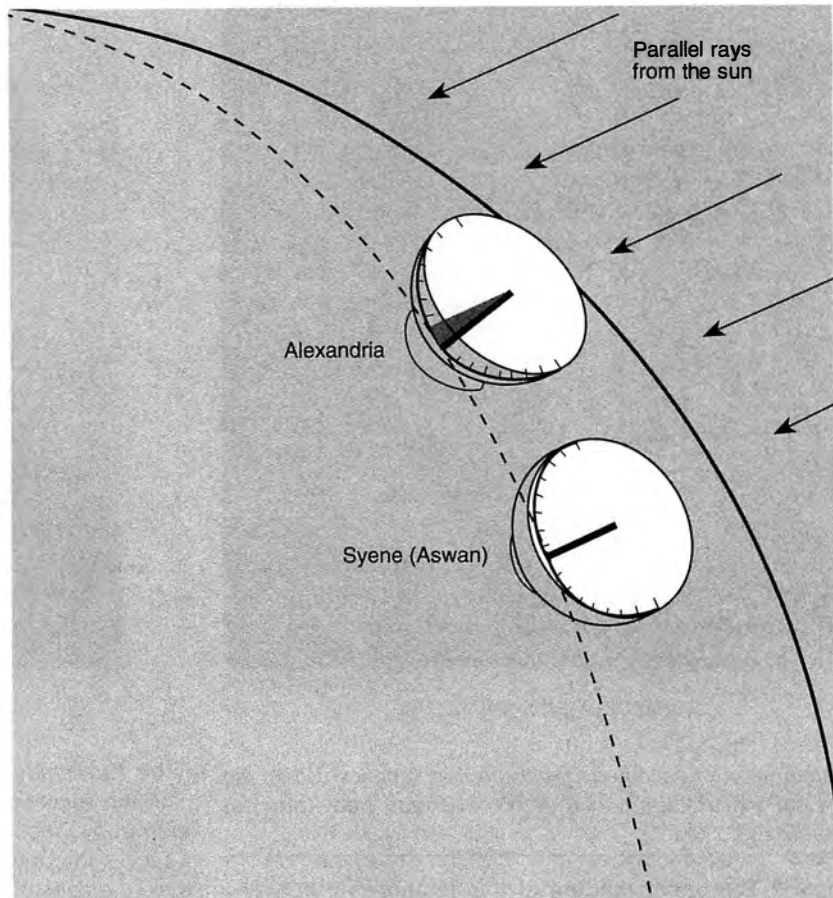

and Riemann as an *hypothesis*, in contrast to the illiterate's misuse of the same term in Newton's famous "et hypotheses non fingo."<sup>17</sup>

The literate usage of "hypothesis," is mandatory in reading even the title of Riemann's June 1854 dissertation, even before proceeding to the body of the text. The key to a literate reading of Riemann's dissertation, is that a topological transformation typified by the transition from a mathematically  $n$ -fold physical-space-time manifold, to an manifold of  $(n+1)$  dimensions, is a transformation in the set of axioms and postulates underlying mathematical physics.

Consequently, the history of those discoveries of physical principle which, like Eratosthenes' discovery of an estimated curvature of the Earth, are validated by the relevant measurement, presents us with a succession of topological changes within mathematical physics, a series of changes which has the form of the "One"/"Many" paradox of Plato's *Parmenides*. In this instance, the "Many" are represented by a series of hypotheses; the challenge is to discover a higher principle, a *higher hypothesis*, a "One," which defines a generative principle by means of which the series of hypotheses, the "Many," is ordered "transfinitely." If Riemann's dissertation is read in any different sense than this Platonic one, the resulting commentary upon the text is a scientifically illiterate one, no matter what the putative classroom authority of the commentator.

Riemann adopts a view of mathematical physics based upon the succession of advances in those discoveries of physical principle which have been validated crucially by relevant measurement, such as Eratosthenes' estimate for curvature of the Earth typifies that principle of measurement. Riemann's view of this topological transformation underlying mathematical physics' progress, thus defines progress in mathematical physics in terms of a sequence of absolute mathematical discontinuities within a formalist reading of mathematical physics itself. It defines Newton, Euler, and Cauchy, for example, as victims of their own scientific illiteracy, victims of an ontological paradox, of the "One"/"Many" form, which they could neither solve, nor comprehend—and, apparently, did not wish to comprehend.

In each case, one formal theorem-lattice is distinguished from another by any change in the axiomatic content, from that of the hypothesis underlying one, to that of the hypothesis underlying the other; every theorem of the second lattice is formally inconsistent with any theorem of the first. The difference between the two hypotheses, is a true, and relatively absolute mathematical discontinuity. Such a "discontinuity" has the same significance in mathematical physics as the proper understanding of the term "metaphor" in Classical forms of poetry or drama. What "discontinuity" signifies respecting the formalities of a consistent mathematical physics, is precisely what "metaphor" signifies for a Classical poem or



Library of Congress

Isaac Newton (1642-1726)



American Institute of Physics

Augustin Cauchy (1789-1857)

*The pantheon of accepted classroom mathematics. When the physical world didn't fit their Procrustean bed, they cut accordingly.*

drama.<sup>18</sup> The understanding of this relationship between metaphor and mathematical discontinuity, is the key to the first of the posthumously published documents, "On Psychology and Metaphysics," presented in the following pages.

In physics, a mathematical discontinuity appears as a mere mark. The magnitude of this mark is of *transinfinitesimal* smallness, so small that no calculable arithmetic magnitude can measure it, yet it exists, nonetheless, as a phenomenon: apparently as a mark of separation of all magnitudes which are less, from all magnitudes which are greater.<sup>19</sup> This mark signifies the functional presence, outside the realm of mathematical formalities, of the mathematical-physical form of what we recognize in Classical poetry as a metaphor.

#### Riemann's 'Geistesmassen'

The fact that all true metaphors are singularities, is the key to an accurate understanding of Riemann's use of *Geistesmassen*, translated here as "thought masses," in the first of the posthumously published papers, "On Psychology and Metaphysics." As an illustration of the principle involved, consider the case of metaphor in either a Classical form of strophic poem, or a song-setting of such a poem by a Mozart,<sup>20</sup> Beethoven, Schubert, Schumann, or Brahms.<sup>21</sup> This case, of the Classical strophic poem, and its musical setting according to principles of motivic thorough-composition, is key for understanding the mental processes by means of which a validatable discovery of new scientific principle is generated.<sup>22</sup> This is also an example of the conception posed by Plato's treatment of the "One/Many" ontological paradox

in his *Parmenides* and other late dialogues.<sup>23</sup>

In the successful Classical poem, efficiently illustrated as to form by Goethe's simple *Mailed*,<sup>24</sup> the strophes represent a succession of metaphors, which march, one after the other, toward a conclusion. The metaphorical attribution of each of those strophes is generated by ironies, to such effect that no proper attribution of either a confining literal or a symbolic meaning for that strophe is to be permitted. The concluding metaphor, especially its final couplet, changes radically the metaphorical attribution—for example, the "meaning"—of the poem as a whole. It is that concluding, subsuming metaphor, which identifies the idea of the poem taken in its entirety.

The literate reading of such a poem, or its Classical song-setting, demands a repeated review of the completed poem, until the point is reached that two conditions are satisfied: first, that the idea of the completed poem as a whole is clear; second, that the relationship of each step of progress within the poem, to the reaching of the conclusion, is clear.<sup>25</sup> The satisfaction of that requirement establishes the idea of the poem as a whole, in the mind, as the product of a tension between two, literally Platonic qualities of idea. The first, is the idea of the completed poem in its entirety; this idea remains unchanged, from prior to the re-reading of the first line, to the momentary silence following the reading of the last line. The second idea, is the successive metamorphoses which the idea of the poem undergoes, in proceeding from the beginning to the end. In Plato, that latter quality of idea is identified as the *Becoming*. It is the tension between the fixed conception, the idea of the completed poem as a whole, and the metamorphical character of the process of *Becoming*, by which the perfected idea is reached, which is the "energy" of the poem.

The same requirement applies to the performance of any



American Institute of Physics

Rudolf Clausius (1822-1882)



Courtesy of Academie Française

Pierre Louis Moreau de Maupertuis (1698-1759)

Classical musical composition. In the simplest case of such a musical performance, it is the performer's memory of reaching the perfected (completed) composition, which creates the tension of reenacting the performance of the metamorphosis, the tension between the perfected idea of the composition, and the moment of development in mid-performance.

The singularity in question is generated by the difference in direction of time-sense—backwards versus forwards—of the two, interacting ideas respecting the poem or musical composition in mid-performance.

The same principle characterizes Eratosthenes' estimate of the curvature of the Earth's surface: the principle of development uncovered, by re-experiencing the mutually contradictory individual readings of the midday sundials, to locate a generating principle of change which is consistent with the final result. For Eratosthenes, the key to the generating principle becomes the relationship between the perimeter of a circle and a pencil of lines, from a momentarily fixed position

of the point corresponding to the Sun, to the Earth. Thus, Eratosthenes gave a reasonable estimation of the Earth's curvature, approximately 22 centuries before any person saw that curvature.

These examples, from poetry, music, and the work of Plato's Academy of Athens, are each and all examples of *Platonic ideas*, the quality of ideas to which Riemann assigns the term *Geistesmassen*. In physical science generally, such ideas have initially the apparent character of ideas arising from vicious inconsistencies within observations made by aid of sense-perception, inconsistencies which mock both naive sense-certainty and generally accepted scientific opinion. Relatively often, that mockery occurs in the most cruelly devastating way. Those ideas which purport to identify the generating principle responsible for this paradox, and which are validated by relevant modes of measurement, represent valid discoveries of physical principle. Those qualities of proven principle are classically identified as *Platonic ideas*. Each and all of the validated

18. The relevant problem is that, many miseducated readers with advanced degrees in arts have the same difficulty in coping with the term "metaphor," which radical positivists experience with the term "mathematical discontinuity." Beginning the early 17th century, the empiricists, such as Thomas Hobbes, launched a vile, energetic, and persisting campaign to eradicate the use of metaphor and the subjunctive mood from English-language usage. The recent emergence of that radical-existentialist decadence known as the "deconstructionism" of Professor Jacques Derrida, et al., is the outgrowth of a centuries-long campaign by the empiricists and logical positivists, and related linguistics specialists, to locate the origin of written language, even Classical poetry, in "text" as such, rather than the irony-rich domain of speech.
19. In the extremely small, discontinuities are compared in respect to their mathematical cardinality, not as arithmetic values. Hence, with deference to Georg Cantor, this distinction is designated here by the usage of "transfinitesimally small."
20. After Mozart's first song composed in the new mode of motivic thorough-composition, his setting of Johann Goethe's "Das Veilchen" ("The Violet"). See *A Manual on the Rudiments of Tuning and Registration*, John

- 1992), Chapter 11, pp. 199-228.
21. Op. cit., pp. 220-221. Note the reference to Gustav Jenner, *Johannes Brahms als Mensch, Lehrer und Künstler: Studien und Erlebnisse* (Marburg an der Lahn: N.G. Elwert'sche Verlagsbuchhandlung, 1930). Jenner's account of Brahms's instruction to him on composing a song for a strophic poem, is directly relevant to the point being developed at this point in the text, above.
22. See Lyndon H. LaRouche, Jr., "Musical Memory and Thorough-composition," *Executive Intelligence Review*, Sept. 1, 1995, pp. 50-63.
23. Plato's *Parmenides* is to be considered as a kind of prefatory piece for all of his later dialogues. In it, he poses the challenge, the ontological paradox, which is the subject addressed in its various aspects by all of the other late dialogues.
24. LaRouche, "Musical Memory and Thorough-composition," p. 55. See note 22.
25. See Jenner's account of his instructions from Brahms, on memorizing a poem with sufficient thoroughness to satisfy those requirements, before undertaking to provide a song-setting for it. See note 21.



American Institute of Physics



Library of Congress

Leonhard Euler (1707-1783) and (right) Immanuel Kant (1724-1804) both attacked Leibniz's not-entropic view of man and the universe and counterposed a world that was axiomatically linearized in the small and in the large.

ideas of "dimensionality" in an  $n$ -fold physical-space-time manifold, have this quality of Platonic idea.

Thus, all such ideas have the form of paradoxical singularities relative to the pre-existing mathematical domain of reference. The character of these ideas as singularities arises from the way in which their existence is generated *subjectively*: by the same kind of processes underlying the reading and composition of a valid Classical strophic poem. The quality of "singularity," and the associated form of mathematical discontinuity, arises from the opposing senses of time associated with the interplay of perfected ideas with the process of their development.<sup>26</sup>

These metaphors can never be deduced from the mathematics, or other form of language employed. Within the language itself, they appear merely in the reflected form of singularities, such as either mathematical discontinuities or other paradoxical adumbrations reflected into the language-medium. The ontological existence of the singularity lies outside the form of generation of the relevant mark within the domain of the language itself.

Thus, every theorem which claims to deny the existence of discontinuities within mathematics, such as Euler's, is based upon *the tautological fallacy of composition, of using constructions premised axiomatically on linearization, to prove the utterly irrelevant point, that any construction of this type is incapable of acknowledging any mathematical existence which is not linear!*

The relevant formal mathematical discontinuity, or literary paradox, is merely the mark which the metaphor imposes, as its footprint, upon the formally defined medium of language. The actual metaphor, which the adumbrated mark, or paradox reflects, exists only outside the medium. It lies within three locations. It lies, first, in the substance of the process which the language is attempting to describe. It also lies,

secondly, in the mental processes of the scientist, or the artist. It exists, thirdly, within the sovereign mental processes of those members of the audience who have responded Socratically to the mark of the singularity, by generating in their own mind a replication of the idea which has imposed its mark upon the medium of communication.

In mathematical physics, the validation of the ideas corresponding to such marks occurs commonly through measurements which demonstrate, that those ideas correspond efficiently to an effect which is not in correspondence with the old ideas which the new ideas profess to supersede.

There is a most notable illustration of this point in the case of Riemann's paper, published in 1860, "On the Propagation of Plane Air Waves of Finite Amplitude."<sup>27</sup> The fact that acceleration toward speeds above the speed of sound generates a singularity, was recognized by Riemann as showing the existence of the transsonic phenomena studied by such followers as Ludwig Prandtl and Adolf Busemann. It was this principle of Riemann's which resulted, through the mediation of a German aerospace specialist, in the first successful powered, post-World War II, supersonic flight by a U.S. aircraft. This was in contrast to the failed contrary opinion expressed by such frequent adversaries of Riemann's work as Hermann Helmholtz, Lord Rayleigh, and Theodor von Karman.<sup>28</sup>

In the relatively more obvious type of case, such as the cited Eratosthenes case, the empirical validation of such a singularity is accomplished by measurements which lie within the domain of arithmetic magnitudes. However, this is not the only primary form of empirical proof of a Platonic idea. As Riemann's referenced paper on shock-waves illustrates the point, in some cases, it is the existence of a non-arithmetic singularity, which has precise cardinality, but not arithmetic magnitude, which presents us the mathematical form of the required proof. Riemann's success in forecasting



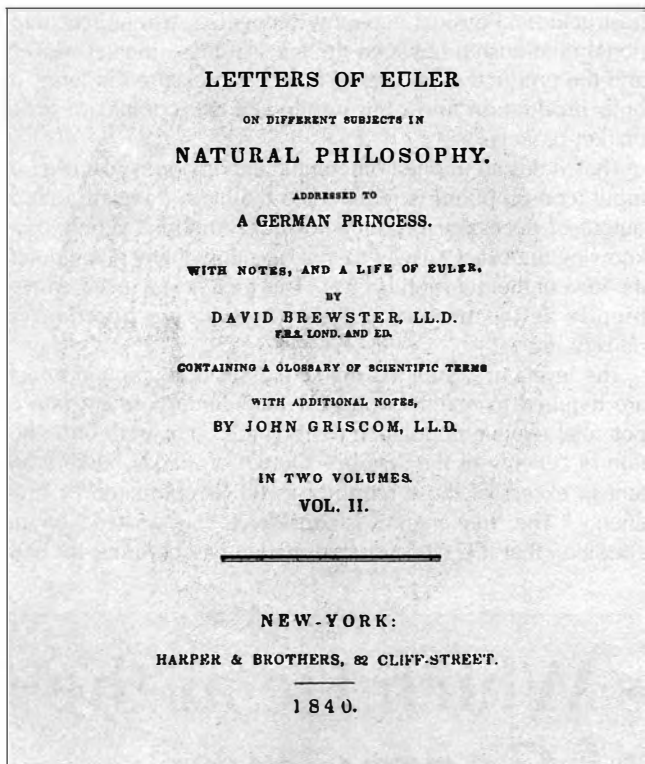

The Letters of Euler on Different Subjects of Natural Philosophy, Addressed to a German Princess, was published in 1770 as part of an ongoing campaign to discredit Leibniz and his collaborators. Translated into French, Russian, and English, it was a bestseller in its day. Here, the title page of an 1840 American edition.

a class of phenomena not necessarily limited to this cited case, not only powered transonic/supersonic flight, but isentropic compression in thermonuclear ignition, is an example of this.

### Leibniz's Universal Characteristic

Respecting the ontological implications of metaphor itself, within these posthumously published pieces, Riemann picks up on a theme addressed earlier by Leibniz, and later revived by the present writer. We must consider the fact, that those efficient Platonic ideas recognizable as validated discoveries of principle, are generated as discoveries within those sover-

eign mental processes of the individual which are impenetrable by symbolic communications-media, such as a formal mathematics. Yet, despite the ethereal quality one might be tempted to attribute wrongly to such mental processes, the result of such ideas is an increase of the human species' physical power to command nature in general.

In this respect, these papers of Riemann turn our attention back to Leibniz's notion of a *Universal Characteristic*, which subsumes, commonly, non-living, living, and cognitive processes within our universe. This is the topical area addressed in the first two of the posthumously published papers: "I. On Psychology and Metaphysics," and "II. Epistemological Issues." After the writing of these papers, Riemann's published work does not refer explicitly again to such epistemological underpinnings of science. From 1854 on, his published work limits itself essentially to mathematical physics, with some impingement upon biophysics,<sup>29</sup> although he clearly did not abandon that personal standpoint in his thinking about mathematical-physics matters. Therein lies some of the special importance of the posthumously published papers for identifying the deeper implications of Riemann's work as a whole.

My own discoveries in physical-economy were rooted in my youthful profession as a follower of Leibniz, and in my developing a rigorous defense of Leibniz against Immanuel Kant's attacks upon him, the latter a matter which bears directly upon the issue of Leibniz's notion of a Universal Characteristic. Furthermore, my discoveries were provoked by both the positivist excesses of Norbert Wiener's "information theory" and the similar incompetence of the work in systems analysis by one of Wiener's followers, John von Neumann; these positivist concoctions I had treated as parodies of Kant's attack on Leibniz. For this reason, my rereading of Riemann brought to that reading the same emphasis upon Leibniz's Universal Characteristic which we encounter in the first two items among Riemann's posthumously published pieces.

The kernel of Wiener's hoax in "information theory," was to adopt and misuse a term, "negative entropy," which had been used earlier chiefly to identify the qualitative distinction between living and non-living processes as they present themselves on the scale of macrophysics.<sup>30</sup>

In successful modern physical economies, my field of study, the biological appearance of "negative entropy" is echoed by the requirement that the ratio of relative "free en-

26. The proper notions of topology are derived from this consideration.

27. "Über die Fortpflanzung ebener Luftwellen von endlicher Schwingungsweite," *Riemann Werke*, pp. 156-175. This was published in an English translation by Uwe Henke and Steven Bardwell, in the Fusion Energy Foundation's *International Journal of Fusion Energy*, Vol. 2, No. 3, 1980, pp. 1-23.

28. There is a relevant story behind the Fusion Energy Foundation's publication of that translation. During the middle to late 1970s, the Fusion Energy Foundation (FEF) gained an international reputation for its important work in promoting inertial confinement fusion. As a consequence of this, in 1978, two representatives of the FEF, Mr. Charles B. Stevens, Jr., and Dr. Steven Bardwell, were invited to the Soviet Union to participate in an international scientific conference on inertial confinement. Prior to their departure, these two FEF representatives met with LaRouche and others, at a Bronx location, to obtain LaRouche's list of requirements for that Moscow visit. LaRouche requested that they ask Soviet scientists for unclassified documents pertaining to the use of Riemann's work on isentropic compression as a basis for the original development of thermonuclear ignition. Such unclassified documentation was obtained, identifying

this Riemann *Fortpflanzung* paper in that connection. It was at a subsequent, "report back" meeting that same year, that LaRouche underlined the application of the same paper to physical-economic modelling, and presented the set of inequalities used to create the highly successful 1980-1983 U.S. Quarterly Economic Forecast of the *Executive Intelligence Review* (EIR) newsweekly.

29. For example, the brilliantly confirmed analysis provided within his *Mechanik des Ohres* (Mechanics of the Ear): *Riemann Werke*, pp. 338-350.

30. As noted, repeatedly, in other locations, this reporter has found it desirable to apportion all physical science among four functionally distinguished domains of inquiry. Two areas, astrophysics and microphysics, are domains in which the scale of phenomena is either too large, or too small, to be addressed directly by the senses. In a third area, biophysics, we deal with the principled distinction between processes, such as organic compounds, which, in one instant are functioning as part of a living process, and, in another instant, not. This also defies simple sense-perception. Those three domains, leave, as residue, the domain of macrophysics, in which sense-perception plays a larger immediate role.

ergy" to "energy of the system" must not decrease, despite the accompanying requirement of rising per capita and per-square-kilometer values of capital-intensity and power-intensity. This desired result is realized, typically, by the fostering of increase of the (physical) productive powers of labor through investment in scientific and technological progress.

Consider the following summary of the relevant argument elaborated in other locations.<sup>31</sup>

Physical economy identifies the primary phenomena of economic processes in terms of market-baskets of both necessary physical consumption and certain crucial classes of services, limited essentially (in modern society) to education, health care, and science and technology as such. These market-baskets are defined per capita (of labor-force), per household, and per square kilometer of relevant land-area employed. The market-baskets are defined for personal consumption, for the processes of production, and for those improvements in land-area used which we class under "basic economic in-

frastructure." Physical economy recognizes a required functional relationship between the level of these market-baskets and the productive powers of labor, as measured in terms of both production and consumption of the content of these market-baskets.<sup>32</sup>

That yields an implied differential expression: What level of input (consumption) is required to maintain a certain rate of output of necessary products for consumption? Without yet knowing the exact answer to that question at any given point, the idea of the question is clear. This idea is expressed conveniently as the notion of *potential relative population-density*.<sup>33</sup>

The levels of combined market-basket consumption which are required to maintain not less than some constant rate of potential relative population-density, are compared to the notion of "energy of the system." Output of market-basket content in excess of those required levels, is compared to "free energy." The "free energy" is considered "not wasted," on the condition that it is consumed in market-basket forms, for both

# On the Hypotheses Which Lie at the Foundations of Geometry

by Bernhard Riemann

*These excerpts from Riemann's 1854 habilitation paper are from the translation by Henry S. White in A Source Book in Mathematics, edited by David Eugene Smith (New York: Dover Publications, 1959), pp. 411-425.*

Notions of quantity are possible only where there exists already a general concept which allows various modes of determination. According as there is or is not found among these modes of determination a continuous transition from one to another, they form a continuous or a discrete manifold; . . .

Determinate parts of a manifold, distinguished by a mark or by a boundary, are called quanta. Their comparison as to quantity comes in discrete magnitudes by counting, in continuous magnitude by measurement. Measuring consists in superposition of the magnitudes to be compared; . . .

\* \* \*

In a concept whose various modes of determination form a continuous manifold, if one passes in a definite way from one mode of determination to another, the modes of determination which are traversed constitute a simply extended manifold and its essential mark is this, that in it a continuous progress is possible from any point only in two directions, forward or backward. If now one forms the thought of this manifold again passing over into another entirely different, here again in a definite way, that

is, in such a way that every point goes over into a definite point of the other, then will all the modes of determination thus obtained form a doubly extended manifold. . . . If one considers his object of thought as variable instead of regarding the concept as determinable, then this construction can be characterized as a synthesis of a variability of  $n + 1$  dimensions out of a variability of  $n$  dimensions and a variability of one dimension. . . .

\* \* \*

. . . [T]here subsists an essential difference between mere relations of extension and those of measurement: in the former, where the possible cases form a discrete manifold the declarations of experience are indeed never quite sure, but they are not lacking in exactness; while in the latter, where possible cases form a continuum, every determination based on experience remains always inexact, be the probability that it is nearly correct ever so great. This antithesis becomes important when these empirical determinations are extended beyond the limits of observation into the immeasurably great and the immeasurably small; for the second kind of relations obviously might become ever more inexact, beyond the bounds of observation, but not so the first kind.

When constructions in space are extended into the immeasurably great, unlimitedness must be distinguished from infiniteness; the one belongs to relations of extension,

expanding the scale of the economy, and increasing the potential relative population-density. In the latter case, the capital-intensity ("energy of the system" per capita, per household, and per square kilometer) must increase, and the power-density must also increase. The requirement is, that the ratio of apparent "free energy" to "energy of the system" must not decrease, despite a rising relative value of "energy of the system" per capita, per household, and per square kilometer.

The increase of potential relative population-density, under the condition that those constraints are satisfied, is treated as the economic-process analog for what is expressed as "negative-entropic" evolutionary self-development of the biosphere in biology and in the terms of reference supplied by the Academician V.I. Vernadsky's notion of biogeochemistry. To avoid confusion with the "information theory's" popularized misuse of the term "negative entropy," the term "not-entropy" is employed instead.

In the field of what Academician V.I. Vernadsky defined as biogeochemistry, this requires the evolution of the biosphere,

the other to those of measure. That space is an unlimited, triply extended manifold is an assumption applied in every conception of the external world; . . . From this, however, follows in no wise its infiniteness, but on the contrary space would necessarily be finite, if one assumes that bodies are independent of situation and so ascribes to space a constant measure of curvature, provided this measure of curvature had any positive value however small. . . .

\* \* \*

. . . [T]he empirical notions on which spatial measurements are based appear to lose their validity when applied to the indefinitely small, namely the concept of a fixed body and that of a light-ray; accordingly it is entirely conceivable that in the indefinitely small the spatial relations of size are not in accord with the postulates of geometry, and one would indeed be forced to this assumption as soon as it would permit a simpler explanation of the phenomena.

The question of the validity of the postulates of geometry in the indefinitely small is involved in the question concerning the ultimate basis of relations of size in space. In connection with this question, which may well be assigned to the philosophy of space, the above remark is applicable, namely that while in a discrete manifold the principle of metric relations is implicit in the notion of this manifold, it must come from somewhere else in the case of a continuous manifold. Either then the actual things forming the groundwork of a space must constitute a discrete manifold, or else the basis of metric relations must be sought for outside that actuality, in colligating [binding together or uniting] forces that operate upon it.

\* \* \*

This path leads out into the domain of another science, into the realm of physics, into which the nature of this present occasion forbids us to penetrate.

to bring the entire system to a higher state of organization; Vernadsky's argument typifies the line of thought which is otherwise encountered in various locations, including Leibniz's notion of a Universal Characteristic, and also the referenced portions of Riemann's posthumously published papers.

Wiener made a mess of everything, with the popularization of his wretched insistence that "negative entropy," for which he employed the neologism "negentropy," was no more than a reversal of the statistical entropy described by Ludwig Boltzmann's H-theorem. Contrary to Wiener's mechanistic schemes, if we account for mankind and mankind's activity as part of the planetary system, man's increased power over nature, typified by the increase of mankind's potential relative population-density,<sup>34</sup> is actually an increase of the relative "negative entropy," or, "not-entropy," of the planetary system as a whole. In other words, mankind's development supplies an evolutionary upward impulse to the totality of the system with which mankind interacts.

In this view of the matter, human cognition has developed within the domain of living processes, but those ecological characteristics of the human species which are entirely due to cognition, place mankind absolutely apart from and above all other living species. Thus, our universe subsumes the interaction among three distinguishable types of processes: non-living, living, and cognitive. The commonly subsuming principle governing such a universe, is Leibniz's notion of a Universal Characteristic.

For today's conventional classroom opinion, what we have just stated poses the question: "Is it not necessarily the case, that if the 'not-entropy' of society increases, that this must occur at the price of increasing the entropy of the universe with which society is interacting?" In other words, is the relationship of society to the remainder of the universe not what von Neumann's devotees term "a zero-sum game"? The crux of the issue, is that the idea of "universal entropy" is not a product of scientific discovery, but of the reckless application of an axiomatically linear, mechanistic world-view, upon the interpretation of the evidence of kinematic models of gases; on this account, there is an amusing ambiguity in the ironical meaning Norbert Wiener's work supplies to the term "gas theory."

The absurdity of the popular version of doctrines of "universal law of entropy," is suggested by the fact, that every rational effort to describe the universe in the large, is an evolutionary model, in which development is vectored as progress to relatively higher states of organization. In mathematical terms, this progress to higher states of organization is indicated by the emergence of physical systems whose characteristics cannot be identified without resort to the mathematics of successively higher cardinalities. The attempt to explain

31. For example, Lyndon H. LaRouche, Jr., "Why Most Nobel Prize Economists Are Quacks," and "Non-Newtonian Mathematics for Economists." See note 6.

32. For example, the case for household consumption was indicated by Gottfried Leibniz in *Society and Economy* (1671), which appears in English translation in *Executive Intelligence Review*, Jan. 4, 1991, pp. 12-13.

33. On "relative population-density," see Lyndon H. LaRouche, Jr., *So, You Wish to Learn All About Economics?* (New York: New Benjamin Franklin House, 1984). This introductory textbook has been published in various languages, including Russian, Ukrainian, and, most recently, Armenian.

34. Per capita of labor-force, per household, and per square kilometer of relevant land-area employed.

the efficient directedness of such universalizing processes of emergence of higher cardinalities, renders absurd every attempt to explain the existence of matter itself in terms of a mechanistic dogma of "building blocks." The evidence is, that recognizably higher physical states of cardinality, are accomplished by transformations of the entire system, not by accretions of objects of a mechanistically fixed domain.

The counterposing of the developmental (for example, not-entropic) and Kant-like mechanistic views is noted by Riemann, in the first of the referenced papers. Crucial is the demonstration, that, as in the case of Euler's absurd 1761 attack on Leibniz's *Monadology*, the presumption of that Kant-like, mechanistic view, from which Rudolf Clausius, Lord Kelvin, and Hermann Grassmann concocted their chimerical "Second Law of Thermodynamics,"<sup>35</sup> is "axiomatic linearization in the small." Create a mathematics, in which all is subsumed under the axiomatic assumption, that everything in the universe is consistent with the Euclidean blind faith in the universality of perfectly continuous linear extension, even into the extremely great and the extremely small. The true believer then regards any formulation which is inconsistent with such a mathematical "proof," as "disproven," and everything which must be assumed to preserve consistency within the theorem-lattice of



Library of Congress

*The Universal Characteristic described by Gottfried Wilhelm Leibniz (1646-1716) corresponds to LaRouche's concept of not-entropy, or man's increasing power over the universe through the use of reason, which is measured in the increase in society's potential relative population-density. Riemann expressed this progress in knowledge topologically as an increasing density of singularities or discontinuities; that is, an increase of the form  $(n+1)/n$ .*

such a mathematics, is considered as "proven" by all of the awesomely credulous professorial, head-nodding dupes attending the relevant conference.<sup>36</sup>

Once we recognize, that such a mathematics constitutes no proof at all respecting the issues immediately at hand, the most generous consideration which the advocates of the "Second Law" might require of rational people, is the famous Scots' verdict, "not proven." No axiom of a mathematics is proven by the employment of the formal mathematical theorem-lattice whose existence depends upon that included assumption.

Those qualifying observations stated, situate the matter at hand. Now, turn directly to the subject of Leibniz's *Universal Characteristic*.

The paradigmatic form of all increase in mankind's potential relative population-density, from the several millions potential of a man-like higher ape, to the billions of today, is changes in social-productive behavior typified by general application of the fruits of scientific and technological progress.<sup>37</sup>

Each of the transmitted discoveries is known by means of the replication of that original act of discovery within the mind of the hearer. On the condition that education of the young proceeds according to that latter principle, present-day knowledge is the accumulation of all of those singularities which valid past discoveries

35. It was Kelvin who proposed to Clausius this radically mechanistic interpretation of Sadi Carnot's work. In this case, as in all of his attacks upon Bernhard Riemann, Clausius relied upon Hermann Grassmann for the mathematical side of his endeavors. See *Riemann Werke*, note on page 293. The crucial role which the axiomatic presumption of linearization in the small played in Grassmann's work, including all of his work on the "Second Law" and attacks upon Riemann, is reflected in his famous 1844 work founding a relevant branch of modern vector analysis, the so-called *Ausdehnungslehre*.

36. During 1978, former FEF Director Morris Levitt dug out a document authored by J. Clerk Maxwell which caused FEF much amusement at that time. In this document, Maxwell responded to the question: Why had Maxwell failed to give credit to such predecessors as Wilhelm Weber and Riemann (and also, most crucially, the founder of electrodynamics, Ampère) for many of the discoveries which Maxwell tacitly presented as either the work of Michael Faraday, or his own? To this, Maxwell replied, that "we," referring to the circles including Kelvin, et al., had chosen to disregard any work which relied upon geometries "different than our own." The same point is made, in similar terms, in Maxwell's principal work. The

implication of Lord Rayleigh's denunciation of Riemann's *Fortpflanzung* paper, is the same: The root of the mechanistic world-view, which the empiricist world-outlook of modern Britain acquired from its ancient master, Paolo Sarpi, is always the presumption of the universality of percussive causality within a universe which is axiomatically linearized in the very small.

37. This progress in the human condition is not due only to scientific and technological progress. The metaphors which arise from Classical forms of poetry, tragedy, and music have as crucial a role in increasing man's power to exist as what we term conventionally "natural science." Nonetheless, as we have already indicated, valid fundamental scientific discoveries merely typify the more general case for all forms of expression of the creative-mental powers of persons as metaphor: as the great English poet Percy Shelley expressed the point, within his "A Defense of Poetry": the "power of communicating and receiving intense and impassioned conceptions respecting man and nature." What is stated above, here, should be read with the understanding that the case for scientific ideas typifies the case for metaphor in general.



have conveyed to the use of the present generations: just as students today would be scientific illiterates, until they re-experience the original discoveries by the members of Plato's Academy at Athens in this way, from Plato, Eudoxus, and Theaetetus, through Eratosthenes. Without a Classical education of the young, in the great Classical works of poetry, tragedy, music, and natural science, going back to the foundations of modern civilization over 2,500 years ago, there cannot be a truly civilized or even rational society, a cruel fact we see enacted so brutally on our streets and in our government and universities today.

Each valid such discovery invokes the principle we have associated here with the topological symbol  $(n+1)/n$ . Each discovery is a singularity of that type. Progress in knowledge is an accumulation of such singularities. As Riemann emphasizes, within the texts provided below, that accumulation of knowledge is interactive, every new concept interacting with every other accumulated within the same mind. Thus, with every thought, this increase of singularities is reflected efficiently: In mathematical terms, the density of discontinuities for any arbitrarily selected interval of human action, is increased. It is this increase of "density of discontinuities" which typifies the form of "not-entropic" and the form of the action which generates "not-entropy" in, for example, the form of increase of society's potential relative population-density.

The crucial fact is, that this increase of knowledge, as defined in this way, is consistently efficient. *The universe obeys the human creative-mental powers' command! Thus, as Genesis 1 prescribes, mankind exerts dominion over nature.* Conversely, the universe is manifestly so constituted, that it is prone to submit to the authority of that power of creative reason which is a potentiality peculiar to the individual human personality.

---

**"The paradigmatic form of all increase in mankind's potential relative population-density, from the several millions potential of a man-like higher ape, to the billions of today, is changes in social-productive behavior typified by general application of the fruits of scientific and technological progress."**

---

By accumulating a reliving of the original valid acts of discovery of principle, which constitute the accumulation of human knowledge to the present date, we are enabled to recognize the distinguishing features of that form of act of creative reason, by means of which valid discoveries have been commonly achieved. That experience becomes known to us, as to Johannes Kepler, as *Reason*, or, as for Gottfried Leibniz, as *necessary and sufficient reason*. Once we recognize, that mankind's cumulative development of knowledge represents the power of the human will to command the universe according to the law embedded in that universe, we have shown ourselves that *reason* as we define it *subjectively* in

## Riemann in English Translation

The few works by Riemann that have previously appeared in English are these:

"On the Hypotheses Which Lie at the Foundations of Geometry," in *A Source Book in Mathematics* edited by David Eugene Smith (New York: Dover Publications, 1959), pp. 411-425. This is Riemann's habilitation dissertation. Excerpts of two other papers are also found in this volume under the title, "On Riemann's Surfaces and Analysis Situs," pp. 404-410.

"On the Propagation of Plane Air Waves of Finite Amplitude," *International Journal of Fusion Energy*, Vol. 2, No. 3 (1980), pp. 1-23.

"The Mechanism of the Ear," *Fusion* Vol. 6, No. 3 (Sept.-Oct. 1984), p. 31-38.

"A Contribution to Electrodynamics," *International Journal of Fusion Energy*, Vol. 3, No. 1 (Jan. 1985), pp. 91-93.

"Gravity, Electricity, and Magnetism according to the Lectures of Bernhard Riemann, compiled by Karl Hattendorf," in *Energy Potential* by Carol White (New York: Campaigner Publications, 1977), pp. 173-293.

\* \* \*

A recent, two-part study of Riemann's method is:

"The Scientific Method of Bernhard Riemann" by Ralf Schauerhammer and Jonathan Tennenbaum, *21st Century Science & Technology*, Winter 1991, pp. 34-42, and Spring 1992, pp. 32-48.

this way, is also an efficient approximation of Reason as it exists, ostensibly *objectively*, as an efficient principle pervading the universe as a whole.

What we recognize in the form of "not-entropy," as in the increase of society's potential relative population-density, is the characteristic of Reason, both as it exists efficiently, "objectively" within the universe at large, and as we are able to adduce the principles of reason, "subjectively," through the efficiency of valid discoveries of principle in the domains of science and art.

Once that is acknowledged, then it is clear to us, that the universe is not linearized in the extremely small, or extremely large. It is "not-entropic," in the extremely small and extremely large, alike. To see this more clearly, it was sufficient, to shift the emphasis in reading Riemann's contributions to mathematical physics, away from physics narrowly conceived, back to the vantage-point of Leibniz, the vantage-point of physical economy, the vantage-point of the efficient relationship between valid human individual reason, and man's increased power over the universe. Thus, we may say, that not-entropy, as reflected in type by Riemann's topological expression  $(n+1)/n$ , corresponds to what Leibniz named a Universal Characteristic.

*Economist Lyndon H. LaRouche, Jr., is a member of 21st Century's scientific advisory board.*

# Euler's Lying Attack on Leibniz

*Letters of Euler on Different Subjects in Physics and Philosophy, Addressed to a German Princess* was published in 1770 as part of a continuing campaign to discredit Leibniz and his collaborators. In this excerpt, Euler describes how the Berlin Academy was used as a center for the attack upon Leibniz:<sup>1</sup>

There was a time when the dispute respecting monads employed such general attention, and was conducted with so much warmth, that it forced its way into company of every description, that of the guardroom not excepted. There was scarce a lady at court who did not take a decided part in favor of monads or against them. In a word, all conversation was engrossed by monads, no other subject could find admission.

The Royal Academy of Berlin took up the controversy, and being accustomed annually to propose a question for discussion and to bestow a gold medal of the value of 50 ducats on the person who in the judgment of the Academy has given the most ingenious solution, the question respecting monads was selected for the year 1748. A great variety of essays on the subject were accordingly produced. The president, Mr. de Maupertuis, named a committee to examine them. . . . Upon the whole, it was found that those [arguments] which went to the establishment of their existence were so feeble, and so chimerical, that they tended to the subversion of all the principles of human knowledge. The question was, therefore determined in favor of the opposite opinion, and the prize adjudged to a Mr. Justi, whose piece was deemed the most complete refutation of the monadists. [Vol. 2, pp. 35-36]

Euler's philosophical outlook is Aristotelian and Newtonian, giving primacy to sense-certainty over reasoned judgment, and his discussion of the history of science is dishonest on all essential questions. For example, he does not give credit to Kepler for his discoveries. Similarly, in the case of the Principle of Least Action, Euler assigns Leibniz's discovery to de Maupertuis. Leibniz was clear that monads were simple substances, without extension, of which all others were compounded. Euler twists Leibniz's words to mean that monads are *infinitely small particles*.

A monad, then, is a substance destitute of all extension, and on dividing a body, till you come to particles so minute, as to be susceptible of no farther division, you have got to the Wolffian monad [Christian Wolff was a disciple of Leibniz], which differs therefore, from the most subtle particle of dust, only in this, that the minutest particles of dust, are not perhaps, sufficiently small, and that a farther division is still necessary to obtain real monads. . . .

The idea which I form of spirits, appears to me incomparably more noble than that of those who consider them as geometrical points, and who reduce God himself to

this class. What can be more shocking than to confound all spirits, and the Supreme Being among the rest, with the minutest particles into which a body is divisible, and to rank them in the same class with these particles, which it is not in the power of the learned term monad to enable? [Vol. 1, pp. 353ff.]

## Leibniz on Metaphysics

A comparison of Euler's attack with Leibniz's writings makes the fraud clear. The best known, perhaps, is Leibniz's essay "The Monadology" (1714). His "Principles of Nature and Grace, Based on Reason," written about the same time, provides a beautiful exposition of his philosophy. Here Leibniz wrote:<sup>2</sup>

So far we have just spoken as simple *physicists*; now we must rise to *metaphysics*, by making use of the *great principle*, little used, commonly, that *nothing takes place without sufficient reason*, that is, that nothing happens without it being possible for someone who knows enough things to give a reason sufficient to determine why it is so and not otherwise. Assuming this principle, the first question we have the right to ask will be, *why is there something rather than nothing?* For nothing is simpler and easier than something. Furthermore, assuming that things must exist, we must be able to give a reason for *why they must exist in this way*, and not otherwise.

This sufficient reason for the existence of the universe cannot be found in the series of contingent things, that is, in the series of bodies and their representations in souls; for, since matter is in itself indifferent to motion and rest, and to one motion rather than another, we cannot find in matter the reason for motion, still less the reason for a particular motion. And although the present motion found in matter comes from the preceding motion, and it, in turn, comes from a preceding motion, we will not make any progress in this way, however far back we go, for the same question always remains. Thus *the sufficient reason*, which needs no other reason, must be outside this series of contingent things, and must be found in a substance which is its cause, and which is a necessary being, carrying the reason for its existence with itself. Otherwise, we would not yet have a sufficient reason where one could end the series. And this ultimate reason for things is called *God*. . . .

It follows from the supreme perfection of God that he chose the best possible plan in producing the universe, a plan in which there is the greatest variety together with the greatest order . . . the greatest effect produced by the simplest means; . . .

And it is surprising that, by a consideration of *efficient causes* alone, or by a consideration of matter, we cannot give the reason for the laws of motion discovered in our time, some of which I myself have discovered. For I have found that we must have recourse to *final causes* for this,

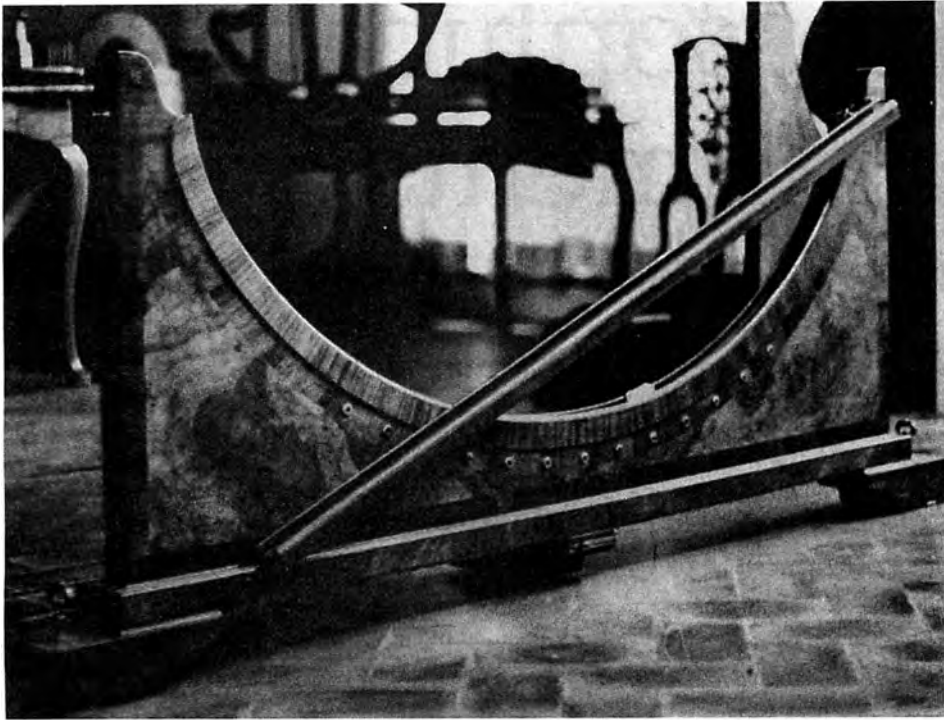

Museo di Storia della Scienza, Florence

An 18th century brachystochrone.

and that these laws do not depend upon the *principle of necessity*, as do logical, arithmetical, and geometrical truths, but upon the *principles of fitness*, that is, upon the choice of wisdom. And this is one of the most effective and most evident proofs of the existence of God for those who can delve deeply into these matters. . . .

As for rational soul, or *mind*, there is something more in it than in monads, or even in the simple souls. It is not only a mirror of the universe of created things, but also an image of the divinity. The mind not only has a perception of God's works, but it is even capable of producing something that resembles them, although on a small scale. . . .

### The Brachystochrone

Leibniz's philosophy and his scientific method were one and the same. In 1696, Leibniz and Johann Bernoulli began studying the brachystochrone, the path of quickest descent of a moving body between any two points on a vertical plane. Although Leibniz was able to solve this problem using an extension of his differential calculus by mapping the relationship between neighboring points of two nearly identical, possible trajectories of the body, and then determining an infinitesimal difference to represent this, this was not the purpose of the study. Leibniz and Bernoulli were able to show that the brachystochrone curve could be determined by mapping the *problem of motion* in a gravitational field, to the propagation of light waves through media of infinitesimally changing density.

Both the propagation of light waves and the propagation of a moving body were determined by least action functions. The brachystochrone was found to be a cycloid—the trajectory of a fixed point on the circumference of a circle, as the circle rolls

along a straight line.

Thus the Calculus of Variations was born. Then Johann Bernoulli and Leibniz extended their investigation to discover the characteristics of families of brachystochrones. What, for instance, would be the curve formed by connecting simultaneous positions of heavy particles which had been released from a given point at the same instant, but which travelled in different directions. This curve they called the *synchrone*, and it turned out to be an orthogonal trajectory identical to the series of wave fronts connected to a ray of light.

This was, in turn, only the beginning of a new series of investigations of the behavior of other families of curves. It was also the starting point for Euler's examination of partial differential equations and variational principles, although in his published work he failed to give credit to Leibniz and the Bernoullis.

Leibniz later wrote a philosophical essay that reflected his earlier studies, the "Tentamen Anagogicum: An Anagogical Essay on the Investigation of Causes." Here he wrote:<sup>3</sup>

Leibniz later wrote a philosophical essay that reflected his earlier studies, the "Tentamen Anagogicum: An Anagogical Essay on the Investigation of Causes." Here he wrote:<sup>3</sup>

The most beautiful thing about this [metaphysical view applied to physics] seems to me to be that the principle of perfection is not limited to the general but descends also to the particulars of things and of phenomena and that in this respect it closely resembles the method of *optimal forms*, that is to say, of forms which provide a maximum or minimum, as the case may be—a method which I have introduced into geometry in addition to the ancient method of *maximal and minimal quantities*. For in these forms or figures the *optimum* is found not only in the whole but also in each part, and it would not even suffice in the whole without this. For example, if in the case of the curve of shortest descent between two given points, we choose any two points on this curve at will, the part of the line intercepted between them is also necessarily the line of shortest descent with regard to them. It is in this way that the smallest parts of the universe are ruled in accordance with the order of greatest perfection; otherwise the whole would not be so ruled.

### Notes

1. The edition of *Letters of Euler* used here is the Henry Hunter translation, 2nd edition, London, 1802.
2. Excerpted from G.W. Leibniz, *Philosophical Essays*, edited and translated by Roger Ariew and Daniel Garber (Cambridge, Mass., and Indianapolis: Hackett Publishing Co., 1989), pp. 209-211. All rights reserved.
3. Excerpted from G.W. Leibniz, *Philosophical Papers and Letters*, edited by Leroy E. Loemker, 2nd edition (Dordrecht: D. Reidel, 1969, reprinted Boston: Kluwer Academic, 1989), p. 478. All rights reserved.

# Philosophical Fragments

by Bernhard Riemann

## Introduction to the Second German Edition

The philosophical speculations whose results—in so far as they can be assembled from his literary remains—are here communicated, concerned Riemann throughout the greater part of his life. Anything definite concerning the time at which these individual fragments were written can hardly be determined. The drafts here are far from being coherent essays ready for publication, even if many passages indicate that Riemann had at certain times intended such a publication; they suffice, in any case, to characterize Riemann's orientation to questions of psychology and natural philosophy in general and to indicate the course taken by his investigations; unfortunately, however, almost every exposition is lacking in detail. The value that Riemann himself placed on these labors can be seen from the following note:

"The tasks that principally concern me now are:

"1. To introduce the imaginary into the theory of other transcendental functions, in a manner similar to the way this has already been done with such great success for algebraic functions, the exponential and cyclical functions, and the elliptical and Abelian functions. To that end, I have supplied the most necessary general preparations in my inaugural dissertation. (See article 20 of this dissertation.)

"2. In connection with this, new methods exist for integration of partial differential equations, which I have already applied to several physical subjects with success.

"3. My principal task concerns a new conception of known natural laws—the expression of these laws by means of other fundamental concepts—through which it becomes possible to use experimental data on the reciprocal action of heat, light, magnetism, and electricity in order to investigate their relations. I was led to this principally through the study of Newton's,

Euler's, and—on the other hand—Herbart's works. Concerning the latter, I could concur almost completely with Herbart's earliest investigations, whose results are expressed in his graduation and habilitation theses (of Oct. 22 and 23, 1802), but I had to diverge from the later course of his speculation on an essential point. I differ with him in regard to natural philosophy and those propositions in psychology which concern their connection to natural philosophy."

Further along, in another place, we find a more exact description of this standpoint:

"The author is a Herbartian in psychology and epistemology (methodology and the theory of perception); he cannot, however, for the most part, agree with Herbart's natural philosophy and the related disciplines (ontology and the study of continua)."

The three fragments unified under the common title "III. Natural Philosophy" have been rearranged in this second edition. Number 2 of the first edition has been exchanged with number 3. According to a conjecture of Dr. Isenkrahe in Bonn which is well supported by internal evidence, it is the essay titled "Gravitation and Light" which is referred to in the passage of Riemann's letter of Dec. 28, 1853, that is cited in the biographical sketch [pp. 539-558 of his *Collected Works*], according to which Riemann had in view a publication of these investigations. The essay, "New Mathematical Principles of Natural Philosophy," with the observation, "Discovered on March 1, 1853," which is concerned with an entirely different set of ideas, is therefore of an earlier origin, and the bold hypothesis expressed in that essay of the disappearance of matter was not further pursued by Riemann.

—Heinrich Weber (1892)

### Translator's Note

This is the first English translation of various sketches left by Riemann at his death in 1866. They were compiled under the title *Fragmente philosophischen Inhalts* (Philosophical Fragments), and first appeared in the 1876 first edition of *Bernhard Riemann's Gesammelte Mathematische Werke und Wissenschaftlicher Nachlass* (Bernhard Riemann's Collected Mathematical Works and Scientific Remains), published by B.G. Teubner. The volume was edited by Heinrich Weber, who later compiled and published *Partial Differential Equations in Mathematical Physics from Riemann's Lectures*.

Teubner published a more complete second edition of Riemann's collected works in 1892, also prepared by Weber, and a supplement of additional materials (*Nachträge*) appeared separately in 1902, edited by M. Noether and W. Wirtinger. These two volumes were later reprinted by various publishers as one. Dover Publications (New

York) issued such a reprint in 1953, with the title *The Collected Works of Bernhard Riemann*, although the only English content was a brief new introduction by Hans Lewy on Riemann's career and thought.

In the German edition of the fragments translated here, the individual pieces are apparently separated by the short, centered rules that have been carried over in this translation. All emphases and ellipses are in the original. Words or phrases in square brackets have been supplied by the translator. Riemann's own footnotes are indicated by asterisks and daggers, while the translator's notes are numbered and appear at the end.

The translation owes its inspiration to Lyndon H. LaRouche, and was done under the supervision of Carol White. Thanks go to William F. Wertz, Jr. and Renée Sigerson for their abundant help.

—David Cherry



## I. On Psychology and Metaphysics

Do not scornfully reject the gifts I have devotedly  
marshalled for you, before you have understood them.

—Lucretius

**W**ith each simple act of thinking, something durable, substantial, enters our mind. This substance appears to us, in fact, as a unity, but it appears (insofar as it is the expression of space and time extension) as comprising a subsumed manifold; I name this a "thought mass."<sup>1</sup> To this effect, all thinking is the development of new thought masses.

The thought masses entering into the mind appear to us to be images; their varying internal states determine how they differ qualitatively.

As they are forming, the thought masses blend; or are folded together, or connect to one another and also to older thought masses, in a precisely determined manner. The character and strength of these connections depend upon causes which were only partially recognized by Herbart, but which I shall fill out in what follows. They rest primarily on the internal relationships among the thought masses.

The mind is a compact, multiply connected thought mass with internal connections of the most intimate kind. It grows continuously as new thought masses enter it, and this is the means by which it continues to develop.

Thought masses once formed, are imperishable; and their connections cannot be dissolved; only the relative strength of these connections is altered by the addition of new thought masses.

Thought masses need no material carrier for their continued existence, and exert no lasting effect upon the physical world. Therefore they are not related to any portion of matter, and have no position in space.

On the other hand, a material carrier is required for every entry, generation, every formation of new thought masses, and for their unification. Thus all thinking does occur at a definite place.

(It is not the retention of our experience but only thinking, which is strenuous; and this exertion of effort, in so far as we can estimate it, is proportional to the mental activity.)

Every thought mass which enters the mind, stimulates all thought mass to which it is related, and does so the more strongly the less the dissimilarity between the internal states (quality).

This stimulation is not confined, however, merely to related thought masses, but also extends, through mediation, to those that are linked with them (that is, connected by previous thought processes). Thus if among the related thought masses, a portion is linked, these will be stimulated not merely directly but also through mediation, and therefore will be stimulated proportionally more strongly than the rest.

The reciprocal action of two thought masses being formed at the same time, is conditioned by a material process between the places where they are both being formed. Likewise, for material reasons, all thought masses being formed enter into unmediated interaction with those formed immediately before; however, through mediation, all older thought masses linked to these will also be stimulated into activity, although to a

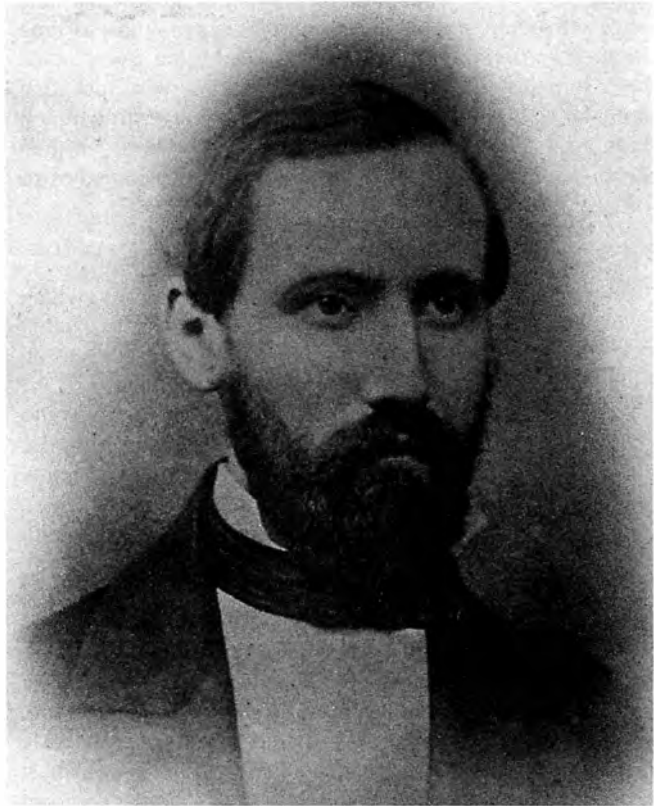

*Bernhard Riemann (1826-1866)*

weaker degree according to the diminished amount and increased distance of their connections.

The most general and simplest expression of the effectiveness of older thought masses is in their reproduction, which occurs when an active thought mass strives to reproduce one similar to itself.

The formation of new thought masses is based partly on the combined effect of older thought masses, partly on material causes; and these, working together, are retarded or advanced according to the internal dissimilarity or similarity of the thought masses whose reproduction is sought.

---

The form of the developing thought mass (or the quality of the image which accompanies its formation) depends upon the relative form of the motion<sup>2</sup> of the matter in which it is shaped, so that a given form of motion of the matter, causes a like form of the thought mass shaped within it; and conversely, whatever the form of the thought mass, it presupposes a like form of motion of the matter in which it is shaped.

All thought masses simultaneously being formed (in our cerebro-spinal system) are connected in consequence of a physical (chemical-electrical) process between the sites where they are formed.

Each thought mass strives to reproduce a thought mass of like form. It therefore tries to recreate the form of motion of the matter in which it is formed.

The assumption of mind as a unified carrier for that which

is enduring—produced by individual acts of mental life (images)—is based upon the following:

1. On the close connection and mutual interpenetration of all images. In order to explain the linking of a particular new image with others, it is however, *not sufficient* to simply assume a unified carrier; rather the cause as to why the given image enters into just such particular connections, with just such particular strengths, must be sought in the images to which it binds itself. Once these causes are given, however, it then becomes superfluous to make the assumption of a unified carrier for all of the images. . . .

Let us now apply these laws of mental processes, to which the explanation of our own inner perception leads, to explain what we perceive to be purposefulness on earth, i.e., to an explanation of existence and historical development.

For the explanation of our mental life, it was necessary to assume that the thought masses which were produced in our nervous system endure as part of our mind; that their internal relations persist without alteration, and that they are subjected to alteration only in so far as they enter into connection with other thought masses.

It is a direct consequence of these principles of explanation, that the minds of organic beings—i.e., the compact thought masses arising during their lives—also continue to exist after their death. (Their isolated continuance is not sufficient.) In order to explain the systematic development of organic nature, however—in which previously gathered experiences obviously serve as the foundation for subsequent creations—we must assume that these thought masses enter into a greater compact thought mass, the biosphere,<sup>3</sup> and there serve a higher mental life, according to the same laws as those which operate when we reproduce thought masses in our nervous system to serve our own mental life.

Take as an example, the case in which we see a red surface. The thought masses produced in an aggregate of individual primitive fibers is bound into a single, compact, thought mass, which enters into our thinking at once. In the same way, the thought masses produced in various individuals of a species of plant, which enter the biosphere from a region of the earth's surface which is not very diverse climatically, will be combined into a single impression. Just as various sense perceptions of the same object are united in our mind into one image of the object, so all plants of one part of the earth's surface will give the biosphere a picture, worked out in the finest detail, of its climatic and chemical condition. In this manner, the way in which the plan for later creations evolved from the earlier life of the earth, can be explained.

But, according to our principles of explanation, the continued existence of thought masses once present, requires no material carrier; yet all of the interconnections, at least every connection between thought masses of different kinds, can only occur by means of the production of newer thought masses by a common process of the nervous system.

For reasons to be developed later, we can seek the carrier for a mental activity only in ponderable matter.

Now it is a fact, that the rigid crust of the earth, along with everything ponderable above it, does not serve a common "mental" process; we can only explain the movement of these ponderable substances by other causes.

## Herbart on the Thought Process

Johann Friedrich Herbart, German philosopher and educational theorist, was the dominant influence on American education in the 1890s, until his classical theory was attacked by radical empiricist John Dewey in 1896.

The following passage from his seminal work, *Outlines of Educational Doctrine* (translated by Alexis F. Lange, New York: Macmillan, 1911)



Johann Friedrich Herbart  
(1776-1841)

is typical of those upon which Riemann drew in formulating his theory of the process of creative discovery in terms of an elaboration of successively higher-dimensional, multiply connected manifolds.

Herbart writes (page 19):

Each body of ideas is made up of complications of ideas, which, if the union is perfect, come and go in consciousness as undivided wholes, and of series, together with their interlacings, whose members unfold successively, one by one, provided they are not checked. The closer the union of parts within these complications and series, the more absolute the laws according to which ideas act in consciousness, the stronger is the resistance against everything opposing their movement; hence the difficulty of acting upon them through instruction. They admit, however, of additions and recombinations, and so may in the course of time undergo essential changes; up to a certain point they even change of themselves if repeatedly called into consciousness by dissimilar occasions, e.g., by the frequent delivery of the same lecture before different audiences.

—David Cherry

Accordingly, the only remaining assumption is that the ponderable masses within the rigid crust of the earth are the carrier for the mental life of the earth.

Are these masses suitable for this purpose? What are the external conditions necessary for the life process? We can establish the foundation for an answer only empirically, on the basis of the living processes that are accessible to our observation; but only insofar as we succeed in explaining them, can we draw conclusions from them which are also applicable to other classes of phenomena.

Empirically, the external conditions of living processes in the range of phenomena accessible to us are:

1. The higher and more completely developed the life-process, the more it is necessary to protect its carrier from external causes of motion which strive to change the relative position of its parts.

2. The physical processes (changes in matter) known to us that serve as a means for the thought process:

- (a) absorption of gas by liquids
- (b) osmosis inward through a cell wall
- (c) formation and decomposition of chemical compounds
- (d) Galvanic currents.

3. The substance of organisms has no recognizable crystal-line structure; it is partly solid (only slightly brittle), partly gelatinous, partly liquid or gaseous, but always porous, that is, markedly penetrable by gases.

4. Among all chemical elements, only the four so-called organic elements are general carriers for the life process, and again, quite definite compounds of these, the so-called organizing compounds, are components of organic bodies (protein, cellulose, etc.).

5. Organic compounds exist only to a definite upper temperature limit, and can be carriers of life only to a definite lower one.

ad. 1. Changes in the relative position of the parts of a body are caused by the following (in decreasing stepwise order of their effect): mechanical forces, changes in temperature, light radiation; accordingly, we can order the facts—of which our proposition is the general expression—as follows:

1. The propagation of lower organisms through division. The gradually decreasing reproductive capacity of higher animal organisms.

2. The parts of plants are the more sensitive to changes in temperature, the more intensive and the more highly developed the life process is in them. In the higher animal organisms, an almost constant temperature governs, especially in their most vital parts.

3. The parts of the nervous system which serve independent thinking are protected against all these influences as much as possible.

Obviously, the foundation for the fact first presented<sup>4</sup> is that, the more the relative position of the parts can be determined by processes occurring within the interior of the matter, the less will it be determined by external motion. This independence from external sources of motion, however, occurs to a far higher degree inside the crust of the earth, than for organic beings on the outside.

In the context of the following facts, taken together, those placed under 4. and 5. [above] are apparently contrary to our assumption; they would be so, in fact, if absolute validity were to be ascribed to those conditions perceived by us for the possibility of a life process, rather than a merely relative validity within the limits of our experience. The following reasons go against their absolute validity, however:

1. All of nature, with the exception of the surface of the earth, would then have to be considered dead, since on all other celestial bodies, temperature and pressure relations predominate under which organic compounds cannot exist.

2. It is absurd to assume that the organic arose from the inorganic on the rigid crust of the earth. In order to explain the origin of the lowest organisms on the earth's crust, some organizing principle must be assumed, and thus a thought process<sup>5</sup> must exist under conditions in which organic com-

pounds could not exist.

We must therefore assume that these conditions are valid only for the life process under the present relationships on the surface of the earth, and only in so far as we are successful in explaining these, can we judge from them the possibility of the life process governed by different relationships.

Why, therefore, are only the four organic elements universal carriers of the life process? The reason can only be sought in properties by which these four elements are distinguished from all others.

1. One such general property of these four elements consists in the fact that they and their compounds are the most difficult to condense of all materials, and, some of them have not yet been condensed at all.

2. Another property which they share is the great multiplicity of their compounds and the ease with which they decompose. This property, however, could just as well be the consequence of their use in living processes as its cause.

However, the former property, that of being difficult to condense, is what makes these four elements preeminently suited to serve life processes. To a certain extent this is directly explainable from the conditions of the life process enumerated under 2. and 3.,<sup>6</sup> but even more if we attempt to trace the phenomena found in the condensation of gases to liquids and solids, back to their causes. . . .

---

*Zend-Avesta* is in fact a life-giving word,\* which creates new life for our mind, in knowledge as in faith. For like many a thought, which indeed was at one time powerfully effective in the course of development of mankind, but is now only preserved for us through tradition, *Zend-Avesta* arises now, all at once, from its apparent death, into a purer form of new life, and reveals new life in nature. Now as the life of nature—previously only manifest on the surface of the earth—is immeasurably extended before our eyes, it appears inexpressibly more sublime. What we considered as the seat of forces working senselessly and unconsciously, now appears as the workplace of the highest spiritual activity. What our great poet has portrayed with prescient inspiration as the goal, which hovered before the mind of the investigator, is now fulfilled in a wondrous way.

Just as Fechner in his *Nanna* seeks to demonstrate that plants possess the characteristics of mind,<sup>7</sup> so the point of departure for his reflections in *Zend-Avesta* is the teaching that stars share characteristics of mind. His method is not to abstract general laws through induction in order to apply and confirm these in the explanation of nature, but rather to reason by analogy. He compares the earth to our own organism, which we know has a mind. He does not merely one-sidedly investigate the similarities, but also does as much justice to the dissimilarities. In this way he obtains the result that all the similarities indicate that the earth is a being possessing characteristics of a mind, and that all of the dissimilarities indicate that it is a being with a mind of a far higher order than our own. The persuasive power of this presentation lies in its many-sided, detailed exposition. The total impression of the picture unfurled for us, of the life of the earth, provides evidence for his view, and compensates for that which the individual conclusions lack in rigor.

---

\* Compare Fechner, *Zend-Avesta*, Vol. 1, Preface, page V.

This evidence rests on the intuitive clarity of the image, and on its execution in the greatest possible detail. I would therefore believe myself to be doing harm to Fechner's view, were I to attempt to present here, in outline, the course he takes in his works. In the following discussion of Fechner's views, I will ignore the form in which they are presented, and consider only the substance, and thus take as a basis the former method, the abstraction of general laws by induction and their confirmation in the explanation of nature.

Let us ask first: From what do we conclude that something has a mind (the occurrence within it of a continuing, unified thinking process)? We are directly aware of our own mind, and with others (human beings and animals), we infer it from individual purposeful movements.

In general, wherever we trace a well-ordered purposefulness back to a cause, we seek this cause in a process of thought; we do not have another explanation. Thinking itself, however, I can only consider as a process which occurs within the interior of ponderable matter. As is evident to anyone who tries to analyze inner perception impartially, it is impossible to explain thinking on the basis of the motion of matter in space; however, the abstract possibility of such an explanation may be conceded here.

No one will deny that purposefulness is perceived on the earth. And so the question arises: Where are we to locate the thought process that is the cause of this purposefulness?

The concern here is only with conditioned purposes (those which take place within limited time and space); unconditional purposes find their explanation in an eternal Will (not produced in a process of thought). The only purposefulness whose cause we perceive is that of our own actions. It originates in willing the end and reflecting upon means.

If we find a body consisting of ponderable matter in which a lattice of continuing, related purposes and actions are completely realized, we can explain this purposefulness by means of a continuing, unified thought process, and this hypothesis will be the most probable if (1) the purposefulness is not completed merely in parts of the body and (2) no reason is present to seek the cause of that purposefulness in a larger whole of which the body is a part.

If we apply this to the purposefulness which we perceive in human beings, animals, and plants, then it follows that a part of this purposefulness is to be explained by a thought process which occurs within these bodies; another part, however, the purposefulness of the organism itself, is to be explained by a process of thinking in a larger whole.

The reasons for this are:

1. The purposefulness of organisms does not find completion in individual organisms. The reasons for the constitution of the human organism are obviously to be sought in the constitution of the entire surface of the earth, with organic nature taken into account.

2. The organism's activities repeat themselves innumerable times, in part simultaneously in different individuals, partly successively in the life of an individual or a generation. For the purposefulness which lies in them already *per se*, we need not assume a special cause in each case, but rather a common cause.

3. In the case of human beings and animals, their constitutions undergo no further development within the lifetime of the single individual, nor (in the case of plants and embryos)

within the life of a single generation. Therefore, the cause of their *purposefulness* is not to be sought in a simultaneously continuing process of thought.

Apart from these aspects of (organic) purposefulness, there is still in man and animals, by common consent—and in plants in Fechner's view—a closed lattice of interpenetrating and variable relations of purpose and action; and this purposefulness is explained by the existence of a unified "thought process" within them.

These conclusions which we draw from our principles are confirmed through our inner perception.

According to the same principles, however, we must look for the reason behind the purposefulness which we perceive in organisms in a unified thought process occurring in the earth, on the following grounds:

- (a) The relationships of purpose and action characteristic of organic life on earth cannot be separated into separate systems; on the contrary, everything is interlocked. They cannot therefore be explained as several particular thought processes, in various parts of the earth.

- (b) There is no basis, as far as our experience goes, for seeking the reason for this purposefulness in a greater whole. All organisms are determined only for life on the earth. The condition of the earth's crust contains, therefore, all the (external) reasons needed to explain how they are organized.

- (c) Organisms found on earth are individual. According to everything that experience teaches, we must assume that they are not replicated on other celestial bodies.

- (d) They do not persist throughout the life of the earth. Instead, new, more perfect organisms are always appearing. We must therefore seek the cause in a thought process that is simultaneously ascending to higher levels.

The assumption of a biosphere is therefore a hypothesis for explaining the existence and the historical development of the organic world, from the standpoint of exact natural science, of a natural explanation from causes.

---

"When the body of the lower soul dies," Fechner says, "the higher soul takes it up from its perceptual life into its life of memory." The souls of deceased creatures are thus said to form the elements for the soul-life of the earth.

The various processes of thought seem to be principally distinguished by their temporal rhythm. If plants possess minds, so must hours and days be for them, what seconds are for us; the corresponding period of time for the earth mind encompasses many millennia, at least, for its outward activity. As far as the historical memory of mankind reaches, all movements of the inorganic crust of the earth are probably to be explained by mechanical laws.

---

## Antinomies

<b>Thesis</b>	<b>Antithesis</b>
The finite, the representable.	Infinite, conceptual systems which lie at the boundary of the representable.
Finite time and space elements.	l. The continuous.



Freedom, i.e., not the capacity to begin absolutely, but rather to decide between two or more given possibilities.

So that decision through choice be possible, despite the existence of fully determinate laws of the working of images, one must assume that the psychic mechanism itself has, or at least takes on, in its development, the characteristic of leading to the necessity of decision through choice.

A God who operates in time (governance of the universe).

Immortality.

Freedom is entirely compatible with the strict lawfulness of the course of nature. But the concept of a timeless God is not tenable beside it. Rather, the limitation which omnipotence and omniscience must suffer through the freedom of creatures, in the sense established above, is removed through the assumption of a God operating in time, who is

II. Determinism.

No one, when acting, can give up the conviction that the future is partly determined by his action.

III. A timeless, personal, omniscient, omnipotent, all-good God (providence).

IV. A thing in itself, which is the basis of our transient existence, endowed with transcendental freedom, radical evil, intelligible character.

a guide for the hearts and fate of man; the concept of providence must be supplemented and in part replaced by the concept of the governance of the universe.

### General Relationship between the Conceptual Systems of Thesis and Antithesis

The method, which Newton used for founding the infinitesimal calculus, and which, since the beginning of this century, has been acknowledged by the best mathematicians as the only one which produces reliable results, is the method of limits. The method consists in this, that instead of considering a continuous transition from one value of a magnitude to another, from one position to another, or in general, from one mode of determination of a concept to another, one first considers a transition through a finite number of intermediate steps, and then allows the number of these intermediate steps to grow, so that the distance between two consecutive intermediate steps decreases *ad infinitum*.

Conceptual systems of antithesis are concepts indeed firmly determined through negative predicates, but not positively representable.

Just because an exact and complete representation of these conceptual systems is impossible, they are not accessible to direct investigation and treatment by our reflection. But they can be considered to lie at the boundary of the representable, i.e., one can form a conceptual system which lies within the representable, but which passes over into the given conceptual system through mere changes in the relative magnitudes. Apart from the relative magnitudes, the conceptual system remains unchanged in the transition to the limit. In the limiting case itself, however, some of the correlative concepts of the system lose their representability, in fact precisely those which mediate the relationship with other concepts.

## II. Epistemological Issues

### Attempt at a Theory of the Fundamental Concepts of Mathematics and Physics as the Foundation for the Explanation of Nature

*Natural science* is the attempt to understand nature by means of exact concepts.

According to the concepts through which we comprehend nature, our perceptions are supplemented and filled in, not simply at each moment, but also future perceptions are seen as necessary. Or, to the degree that the conceptual system is not fully sufficient, future perceptions are determined beforehand as probable; according to the concepts, what is "possible" is determined (thus also what is "necessary," and conversely, impossible). And the degree of possibility (of "probability") of each individual event which is seen as possible, in light of these concepts, can be mathematically determined, if the concepts are precise enough.

To the extent that what is necessary or probable, according to these concepts, takes place, then this confirms the concepts, and the trust that we place in these concepts rests on this

confirmation through experience. But if something takes place that is unexpected according our existing assumptions, i.e., that is impossible or improbable according to them, then the task arises of completing them or, if necessary, reworking the axioms, so that what is perceived ceases to be impossible or improbable. The completion or improvement of the conceptual system forms the "explanation" of the unexpected perception. Our comprehension of nature gradually becomes more and more complete and correct through this process, simultaneously penetrating more and more behind the surface of appearances.

The history of causal natural science, in so far as we can trace it back, shows that this is, in fact, the way our knowledge of nature advances. The conceptual systems that are now the basis for the natural sciences, arose through a gradual transformation of older conceptual systems, and the reasons that drove us to new modes of explanation can always be traced back to contradictions and improbabilities that emerged from the older modes of explanation.

The formation of new concepts, in so far as this process is

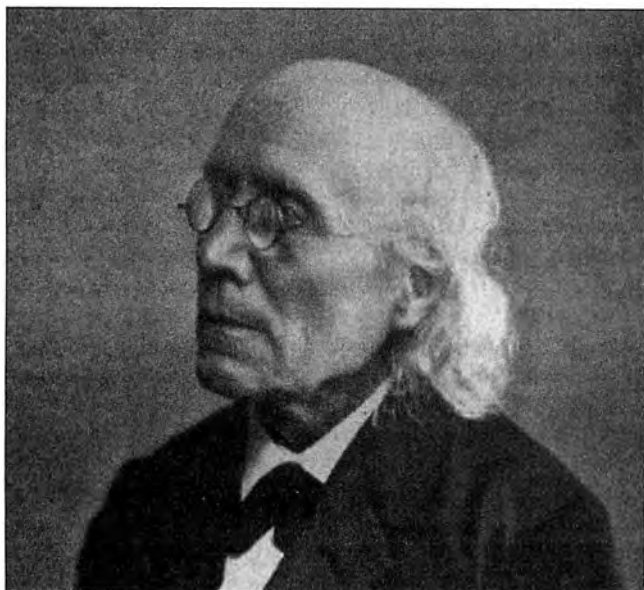

Gustav Fechner (1801-1887) was an experimental psychologist and professor of physics at the University of Leipzig from 1834 until 1839, when he resigned because of illness. His work, however, continued to be very wide-ranging after his subsequent recovery. He is remembered today chiefly in connection with Fechner's (or Weber's) law that stimuli are perceived by the mind with logarithmic compression: The intensity of a sensation increases arithmetically if the intensity of the stimulus increases geometrically.

accessible to observation, therefore takes place in this way.

Herbart furnished the proof that concepts that allow us to comprehend the world—those whose origin we can trace neither in history nor in our own development, because they are delivered to us unnoticed through our language—can be derived from this source, in so far as they are more than mere forms combining simple sense images; and therefore these concepts need not be derived from some special constitution of the human mind which precedes all experience (such as Kant's categories).

This proof of their origin in our ability to comprehend that which is given to us by sense perception, is important for us, because it is only in this way that their meaning can be determined in a manner satisfactory for science. . . .

After the concept of things existing in themselves has been formed, then in reflecting on the process of change, which contradicts the concept of things existing in themselves, the task arises of maintaining this already proven concept as far as possible. From this problem arise simultaneously the concepts of continuous change and causality.

All that is observed is the transition of a thing from one state into another, or, to speak more generally, from one mode of determination to another, without a sudden jump being perceived in the transition. In order to complete the observations, we can either assume that the transition occurs through a very great, but finite, number of leaps imperceptible our senses, or that the thing goes continuously through *all* of the intermediate steps, taking it from one state to the other. The

strongest reason for the latter conception is the demand to maintain as far as possible, the already proven concept of the existence of the thing in itself. Of course, it is not possible to actually represent such a transition through *all* intermediate steps, which, however, as noted, is valid, strictly speaking, for all concepts.

At the same time, however, according to the concept of the thing in itself, formed earlier and proven by experience, the thing would remain what it is, unless something else intervened. This creates the impulse to seek a cause for every change.

---

I. When is our comprehension of the world true?

"When the relations among our conceptions correspond to the relations of things."

The elements of our picture of the world are completely distinct from the corresponding elements of the reality which they picture. They are something within us; the elements of reality are something outside of ourselves. But the connections among the elements in the picture, and among the elements of reality which they depict, must agree, if the picture is to be true.

The truth of the picture is independent of its degree of fineness; it does not depend upon whether the elements of the picture represent larger or smaller aggregates of reality. But, the connections must correspond to one another; a direct action of two elements upon each other may not be assumed in the picture, where only an indirect one occurs in reality. Otherwise the picture would be false and would need correction. If, however, an element of the picture is replaced by a group of finer elements, so that its properties emerge, partly from the simpler properties of the finer elements, but partly from their connections, and thus become in part comprehensible, then this increases our insight into the connection of things, but without the earlier understanding having to be declared false.

II. How do we find the relations among things?

"From the connections of phenomena."

The representation in determinate space-and-time relations of things of the senses is something met with in deliberate reflection on nature or is *given* in that reflection. However, as we well know, the *quality* of the characteristics of things of the senses—color, sound, tone, smell, taste, heat or cold, is something merely derived from our own sensations and does not exist outside of ourselves.

The relations among things must therefore become known to us from *quantitative* relations, the spatial and temporal relations of things of the senses and the relative intensities of their characteristics and their qualitative differences.

Knowledge of the connections among things must arise from reflection on the observed relations of these relations of magnitudes.

---

**Causality**

I. What an action strives to accomplish must be determined through the concept of the action; its acting cannot be dependent upon anything else than the action's own being.

II. This demand is satisfied when the action strives to maintain or restore *itself*.

III. Such an action is not conceivable, however, if the action is a thing, a being; but only if it is a state or a relationship. If a

striving exists, to maintain or restore something, then deviations from this something must also be possible—and indeed in different degrees. And in so far as this striving conflicts with other strivings, it will in fact be maintained or restored only to the extent possible. But there is no gradation of being; a difference of degrees is conceivable only for states or relationships. If therefore, an action strives to maintain or restore *itself*, it must be a state or a relationship.

IV. Obviously, such action can only occur in those things that can assume such a state. But in which of these things it occurs, and whether it occurs in them at all cannot be determined from the concept of the action.\*

Kant quite rightly notes that we can neither discover the existence of a thing, nor that it is the cause of something else, merely from analysis of the concept of the thing; so that the concepts of being and causality cannot be derived from analysis but only from *experience*. When, however, he later believes

\* These theses are valid only if the effect is to be ascribed to a simple real cause. If two things *a* and *b* are connected through an external cause, then a consequence *c* can be ascribed either to the connection, the process of being connected itself, or else to a change in the degree of the connection. The simplest assumption is that the consequence *c* can be ascribed to the process of being connected.

It is unnecessary to take these considerations further. Their principle consists in holding to the thesis: "What an action strives to effect must be determined from the concept of the action"; but this thesis must be applied, not as Leibniz or Spinoza did, to beings with a manifold of determinations, but rather to real causes of the greatest possible simplicity.

In German, one tends to translate "actio" as well as "effectus" by "Wirkung [effect]." Since the word occurs in the latter sense more commonly, unclarity easily arises if it is used for "actio," as, for example, with the standard translation of "actio aequalis est reactioni [action and reaction are equal]," or "principium actionis minimae [principle of least action]." Kant seeks to remedy this by adding the Latin expressions "actio" and "actio mutua" in parenthesis to "Wirkung" and "Wechselwirkung [interaction]." "One could perhaps write, "die Kraft ist gleich der Gegenkraft [the force is equal to the opposing force]." "Satz vom kleinsten Kraftaufwande [the principle of least expenditure of force]." Since, in fact, we lack a simple expression for "agere," a striving directed toward something else, I may be permitted the use of the foreign word [agens, action].

### III. Natural Philosophy

#### 1. Molecular Mechanics

The free movement of a system of material points  $m_1, m_2, \dots$  with rectangular coordinates  $x_1, y_1, z_1; x_2, y_2, z_2; \dots$ , on which forces  $X_1, Y_1, Z_1; X_2, Y_2, Z_2; \dots$  act in parallel to the three axes, takes place according to the equations

$$(1) \quad m_1 \frac{d^2 x_1}{dt^2} = X_1, \quad m_1 \frac{d^2 y_1}{dt^2} = Y_1, \quad m_1 \frac{d^2 z_1}{dt^2} = Z_1,$$

This law can also be expressed as follows: The accelerations are so determined that

$$\sum m_i \left( \left( \frac{d^2 x_i}{dt^2} - \frac{X_i}{m_i} \right)^2 + \left( \frac{d^2 y_i}{dt^2} - \frac{Y_i}{m_i} \right)^2 + \left( \frac{d^2 z_i}{dt^2} - \frac{Z_i}{m_i} \right)^2 \right)$$

becomes a minimum; for this function of the accelerations takes its smallest value 0 if the accelerations collectively are determined in accordance with equation (1), that is, the magni-

himself compelled to assume that the concept of causality precedes all experience, this is tantamount to throwing the baby out with the bath; because this implies that the mind would be preconditioned to accept any perception, given by experience, as a cause, if it could be connected to *any other arbitrary one* as effect, according to a rule of mere sequence. (Of course, we must derive the relationships of causality from experience, but we must not dispense with correcting and completing our comprehension of the data of experience through reflection.)

The word hypothesis now has a somewhat different meaning than with Newton. We are now accustomed to understand by hypothesis all that is added by thought to phenomena.

Newton was far from the absurd thought that the explanation of phenomena could be gained by abstraction from experience.

Newton: [In Latin from the General Scholium of *Principia Mathematica*] "And thus much concerning God; to discourse of whom from the appearances of things, does certainly belong to natural philosophy. [. . .] But hitherto I have not been able to discover the cause of those properties of gravity from phenomena, and I frame no hypotheses."

Arago, *Oeuvres Complètes*, Vol. 3, 505:

[In French] "Once and once only did Laplace rise into the realm of conjecture. His conception at that time was nothing less than a cosmogony."

Laplace in response to Napoleon's question, why the name God did not occur in his *Celestial Mechanics*: [in French] "Sire, I have no need for that hypothesis."

The distinction that Newton makes between laws of motion, or axioms, and hypotheses, does not seem tenable to me. The law of inertia is the hypothesis: If a material point were present alone in the world and moved in space with a definite velocity, then it would constantly maintain this velocity.

tudes  $\frac{d^2 x_1}{dt^2} - \frac{X_1}{m_1} \dots$  collectively = 0, and they also take the minimum value only then; for, were one of these magnitudes, for example,  $\frac{d^2 x_1}{dt^2} - \frac{X_1}{m_1}$  not equal to 0, then  $\frac{d^2 x_1}{dt^2}$  could continuously change so that the absolute value of this magnitude and consequently its square would decrease. The function would thus become smaller if all the other accelerations were simultaneously left unchanged.

This function of the accelerations is distinguished from

$$\sum m_i \left( \left( \frac{d^2 x_i}{dt^2} \right)^2 + \left( \frac{d^2 y_i}{dt^2} \right)^2 + \left( \frac{d^2 z_i}{dt^2} \right)^2 \right) - 2 \sum \left( X_i \frac{d^2 x_i}{dt^2} + Y_i \frac{d^2 y_i}{dt^2} + Z_i \frac{d^2 z_i}{dt^2} \right)$$

only by a constant, that is, by a magnitude independent of the accelerations.

If the forces between points result only from attraction and repulsion, which are functions of distance, and the  $i$ th point and the  $i'$ th point at a distance  $r$  repulse one another with a force  $f_{i,i'}(r)$  or attract one another with the force  $-f_{i,i'}(r)$  then, as is known, the components of the forces can be expressed through the partial derivatives of a function of the coordinates of all the points

$$P = \sum_{i,i'} F_{i,i'}(r_{i,i'}),$$

where  $F_{i,i'}(r)$  is a function with derivative  $f_{i,i'}(r)$ , and for  $i$  and  $i'$  two different indices are set for each.

If these values of the components

$$X_i = \frac{\partial P}{\partial x_i}, \quad Y_i = \frac{\partial P}{\partial y_i}, \quad Z_i = \frac{\partial P}{\partial z_i}$$

are substituted into the above function of the accelerations and are multiplied by  $\frac{dt^2}{4}$ , through which the positions of their maxima and minima are not changed, then we obtain an expression which is distinguished from

$$\frac{1}{4} \sum \left( \left( d \frac{dx_i}{dt} \right)^2 + \left( d \frac{dy_i}{dt} \right)^2 + \left( d \frac{dz_i}{dt} \right)^2 \right) - P_{(t+dt)}$$

only by a magnitude which is independent of the accelerations. If the position and the velocities of the points at time  $t$  are given, then this position is determined at time  $t + dt$  such that this magnitude becomes as small as possible. Accordingly, there is a striving for this magnitude to become a minimum.

This law can be explained on the basis of actions which strive to make the individual terms of this expression as small as possible if we assume that the strivings working against one another are so equalized that the sum of the magnitudes which the individual actions strive to maintain at a minimum, becomes itself a minimum.

If we assume that the masses of the points  $m_1, m_2, \dots, m_n$  behave like the whole numbers  $k_1, k_2, \dots, k_n$ , so that  $m_i = k_i \mu$ , then the expression, which becomes as small as possible, consists of the sum of the magnitudes

$$\frac{\mu}{4} \left( \left( d \frac{d^2 x_i}{dt} \right)^2 + \left( d \frac{d^2 y_i}{dt} \right)^2 + \left( d \frac{d^2 z_i}{dt} \right)^2 \right)$$

for the totality of material particles  $\mu$  and of magnitude  $-P_{t+dt}$ . If we therefore, with Gauss, consider the magnitude

$$\left( d \frac{d^2 x_i}{dt} \right)^2 + \left( d \frac{d^2 y_i}{dt} \right)^2 + \left( d \frac{d^2 z_i}{dt} \right)^2$$

as the measure of the deviation of the state of motion of mass  $\mu$  at time  $t + dt$  from its state of motion at time  $t$ , then the analysis of the total action in relation to each mass yields an action which strives to make the deviation of its state of motion at time  $t + dt$  as small as possible relative to its state of motion at time  $t$ , or an effort to preserve its state of motion, and,

additionally, an action which strives to keep the magnitude  $-P$  as small as possible.

The latter action can be analyzed into efforts to keep the individual terms of the sum  $\sum_{i,i'} F_{i,i'}(r_{i,i'})$  as small as possible, that is, into attractions and repulsions between any two points, and this would lead us back to the customary explanation of the laws of motion from the law of inertia and of attraction and repulsion; but it can also lead us back, for all natural forces known to us, to the forces that act between contiguous spatial elements, as will be explained in the following article on gravitation.

## 2. New Mathematical Principles of Natural Philosophy\*

Although the title of this essay will hardly create a favorable impression on most readers, it nonetheless seems to me to best express the overall direction of the essay. Its purpose is to penetrate beyond the foundations of astronomy and physics laid by Galilei and Newton, into the interior of nature. For astronomy, certainly these speculations cannot immediately have any practical use, but I hope that this circumstance will not cause any diminution of interest in the eyes of the readers of this publication. . . .

The foundation for those general laws of the motion of ponderable bodies that are presented at the beginning of Newton's *Principia* lies in the internal state of these bodies. Let us attempt to form an analogy between these and our own inner mode of perception. New image masses constantly arise in us and very rapidly disappear again from our consciousness. We observe a constant activity of our mind. Every mental act is based upon something enduring, which is manifest (through memory) on certain occasions, without exerting a lasting influence on the phenomena. Thus (with every act of thinking) something enduring continually enters our mind, which does not however, exert a lasting influence upon the world of phenomena. Every mental act, therefore, is based upon something enduring, which enters our mind with the act, but at the same moment completely disappears from the world of phenomena.

Guided by this fact, I form the hypothesis that there is a kind of space-filling substance which continually flows into ponderable atoms and there disappears from the world of phenomena (the corporeal world).<sup>8</sup>

Both hypotheses can be replaced by the one, that in all ponderable atoms, substance from the corporeal world continuously enters into the world of mind. The reason the substance disappears there is to be sought in the thought matter which was formed in the immediately preceding period; and the ponderable bodies are accordingly the place where the world of mind engages the corporeal world.†

The effect of universal gravitation, the first thing to be explained by this hypothesis, is well known to be fully determined for every part of space, if the potential function  $P$  of all ponderable mass for this part of space be given, or, which is the same

\* Discovered on March 1, 1853.

† At every instant, a definite quantity of substance, proportional to the gravitational force, enters into every ponderable atom, and disappears there.

It is a consequence of the psychology based on Herbart's work, that substantiality accrues not to the mind but to every individual image formed within it.



thing, there is a function of position  $P$ , such that the ponderable masses contained within the closed surface  $S$ , are  $\frac{1}{4\pi} \int \frac{\partial P}{\partial \rho} dS$ .

If we now assume that the substance that fills space is an incompressible homogeneous fluid, without inertia, and that an amount proportional to the mass of any given atom flows into it during equal times, then obviously, the pressure exerted on the ponderable atom (will be proportional to the velocity of the substance at the site of the atom?)<sup>9</sup>

Thus the effect of universal gravitation on a ponderable atom can be expressed through (and thought of as dependent upon) the pressure of this space-filling substance in the immediate neighborhood of the atom.

It necessarily follows from our hypothesis that the space-filling substance must propagate the vibrations that we perceive as light and heat.

If we consider a simple polarized beam, and designate as  $x$  the distance of an indeterminate point of this beam from a fixed origin, and  $y$  its displacement at a time  $t$ , then the following equation must be at least very nearly satisfied, since the velocity of propagation of the vibrations in space free of ponderable atoms is under all conditions very nearly constant ( $= \alpha$ ):

$$y = f(x + \alpha t) + \varphi(x - \alpha t).$$

For it to be strictly satisfied,

$$\frac{\partial y}{\partial t} = \alpha \alpha \int \frac{\partial^2 y}{\partial x^2} d\tau$$

would have to apply; obviously, however, for the sake of experiment, we can be satisfied with the equation

$$\frac{\partial y}{\partial t} = \alpha \alpha \int \frac{\partial^2 y}{\partial x^2} \varphi(t - \tau) d\tau$$

even if  $\varphi(t - \tau)$  is not equal to 1 for all positive values of  $t - \tau$  (which decreases *ad infinitum* with increasing  $t - \tau$ ), as long as for a sufficiently long period of time it remains very close to 1. . . .

Let the positions of the points of the substance at a given time  $t$  be expressed by a rectilinear coordinate system and let the coordinates of an indeterminate point  $O$  be  $x, y, z$ . Similarly, let the coordinates of a point  $O'$  be  $x', y', z'$ , also with regard to a rectilinear coordinate system. Then  $x', y', z'$  are functions of  $x, y, z$ , and  $ds'^2 = dx'^2 + dy'^2 + dz'^2$  will be equal to a homogeneous quadratic expression of  $dx, dy, dz$ . According to a well-known theorem, the linear expressions of  $dx, dy, dz$

$$\begin{aligned} \alpha_1 dx + \beta_1 dy + \gamma_1 dz &= ds_1 \\ \alpha_2 dx + \beta_2 dy + \gamma_2 dz &= ds_2 \\ \alpha_3 dx + \beta_3 dy + \gamma_3 dz &= ds_3 \end{aligned}$$

can now always in one and only one way be determined, such that

$$dx'^2 + dy'^2 + dz'^2 = G_1^2 ds_1^2 + G_2^2 ds_2^2 + G_3^2 ds_3^2$$

while

$$ds^2 = dx^2 + dy^2 + dz^2 = ds_1^2 + ds_2^2 + ds_3^2.$$

The magnitudes  $G_1 - 1, G_2 - 1, G_3 - 1$  then signify the major deformations for the particle of substance at  $O$ , in the transition from the former form to the latter. I indicate them by  $\lambda_1, \lambda_2, \lambda_3$ .

Now I assume that a force results from the difference between the earlier forms of the particle of substance and its form at time  $t$ , which strives to change it; and, other things being equal, that the influence of an earlier form will become the less the longer the time prior to  $t$  when it occurred. Thus there is a limit before which all earlier forms can be ignored. I further assume that those states that still manifest a detectable influence differ so slightly from the state at time  $t$ , that the deformations may be regarded as infinitely small. The forces that strive to make  $\lambda_1, \lambda_2, \lambda_3$  small can then be regarded as linear functions of  $\lambda_1, \lambda_2, \lambda_3$ ; and indeed, because of the homogeneity of the aether for the total moment of these forces (the force which strives to make  $\lambda_1$  small must be a function of  $\lambda_1, \lambda_2, \lambda_3$ , which remains unchanged when we exchange  $\lambda_2$  with  $\lambda_3$ , and the remaining forces must follow from it, when  $\lambda_2$  is exchanged with  $\lambda_1$ , and  $\lambda_3$  with  $\lambda_1$ ) we obtain the following expression:

$$\begin{aligned} \delta \lambda_1 (a \lambda_1 + b \lambda_2 + b \lambda_3) + \delta \lambda_2 (b \lambda_1 + a \lambda_2 + b \lambda_3) \\ + \delta \lambda_3 (b \lambda_1 + b \lambda_2 + a \lambda_3) \end{aligned}$$

or with a somewhat changed meaning of the constants:

$$\begin{aligned} \delta \lambda_1 (a(\lambda_1 + \lambda_2 + \lambda_3) + b \lambda_1) + \delta \lambda_2 (a(\lambda_1 + \lambda_2 + \lambda_3) + b \lambda_2) \\ + \delta \lambda_3 (a(\lambda_1 + \lambda_2 + \lambda_3) + b \lambda_3) \\ = \frac{1}{2} \delta (a(\lambda_1 + \lambda_2 + \lambda_3)^2 + b(\lambda_1^2 + \lambda_2^2 + \lambda_3^2)). \end{aligned}$$

Now the moment of the force that strives to change the form of the infinitely small particle of substance at  $O$ , can be regarded as resulting from forces that strive to change the length of the line elements ending at  $O$ . We therefore arrive at the following law of action: If  $dV$  is the volume of an infinitely small particle of substance at point  $O$  and time  $t$ , and  $dV'$  the volume of the same particle at time  $t'$ , then the force resulting from the difference in the two states of the substance, which strives to elongate  $ds$ , is expressed by

$$a \frac{dV - dV'}{dV} + b \frac{ds - ds'}{ds}.$$

The first part of this expression derives from the force with which a particle of substance resists a change in volume without a change of form, the second from the force with which a physical line element resists a change in length.

Now there is no reason to assume that the effects of both causes change with time in accordance with the same law; thus if we sum the effects of all earlier forms of a particle of substance upon the change of the line element  $ds$  at time  $t$ , then the value of  $\frac{\delta ds}{dt}$ , which they strive to determine, becomes

$$= \int_{-\infty}^t \frac{dV' - dV}{dV} \psi(t - t') \delta t' + \int_{-\infty}^t \frac{ds' - ds}{ds} \varphi(t - t') \delta t'.$$

How then must the functions  $\psi$  and  $\varphi$  be constituted such that

gravitation, light, and radiant heat may be propagation through the substance of space?

The effects of ponderable matter upon ponderable matter are:

(1) Attractive and repulsive forces inversely proportional to the square of the distance.

(2) Light and radiant heat.

Both classes of phenomena can be explained if we assume that the entirety of infinite space be filled with a homogeneous substance and that every particle of that substance acts directly only upon its immediate neighborhood.

The mathematical law in accordance with which this occurs can be thought of as divided into

(1) the resistance of a particle of substance to a change in volume, and

(2) the resistance of a physical line element to a change in length.

Upon the first part are founded gravitation and electrostatic attraction and repulsion; upon the second, the propagation of light and heat, and electrodynamic or magnetic attraction and repulsion.

### 3. Gravitation and Light

The Newtonian explanation of gravitational motion and the motions of celestial bodies consists in the assumption of the following causes:

1. There exists an infinite space with the properties which are assigned to it by geometry, and there exist ponderable bodies which change their positions within this space only continuously.

2. At every mass-point, there is at every moment a cause determined by magnitude and direction, by virtue of which cause the mass-point has a determinate motion (matter in a determinate state of motion). The measure of this cause is velocity.\*

The phenomena to be explained here do not yet lead to the assumption of different masses for ponderable bodies.

3. At every point of space, there exists at every moment a cause (accelerating force), determined by magnitude and direction, which communicates a determinate motion to every mass point present, and indeed, the same motion to each, which combines geometrically with the motion that it already has.

4. At every mass-point in space, there exists a cause (absolute gravity) determined by magnitude, which combines geometrically with all other accelerating forces present there. By virtue of this cause, at every point of space an accelerating force exists, inversely proportional to the square of its distance from this

\* Every material body, if alone in space, would either not change its position in space or would move in a straight line with constant velocity.

This law of motion cannot be explained by means of the Principle of Sufficient Reason: That the body continues its motion, must have a cause, which can only be sought in the internal state of the matter.

† The same mass point would undergo changes in motion between two points, whose directions coincide with the directions of the forces and whose magnitudes are proportional to the forces.

The force divided by the change in motion, therefore, always gives the same quotient for the same mass-point. This quotient is different for different mass-points and is called their mass.

mass-point and directly proportional to its gravitational force.†

The cause, determined according to magnitude and direction (accelerating gravitational force), which, according to 3., is found at every point in space, I seek in the form of motion of a substance that is continuously spread through all infinite space, and, indeed, I assume that the direction of the motion is equal to the direction of the force from which it is to be explained, and the velocity is proportional to the magnitude of the force. This substance can therefore be represented as a physical space whose points move in geometrical space.

According to this assumption, all effects caused by ponderable bodies on ponderable bodies through empty space must be propagated by this substance. Therefore also the forms of motion of which light and heat consist, which celestial bodies transmit to one another, must be forms of motion of this substance. These two phenomena, however, gravitation and the motion of light through empty space, are the only ones that must be explained *purely* by means of the motions of this substance.

Now I assume that the actual motion of the substance in empty space is combined from the motion which must be assumed for explanation of gravitation and that which must be assumed for the explanation of light.

The further development of this hypothesis can be divided into two parts in that the following are to be sought:

1. The laws of motion of the substance which must be assumed for the explanation of the phenomena.

2. The causes by means of which these motions can be explained.

The first subject is mathematical, the second, metaphysical. In reference to the latter, I note in advance that the goal will not be considered to be any explanation on the basis of causes that strive to change the distance between two points of the substance. This method of explanation by means of attractive and repulsive forces owes its general application in physics not to any direct evidence (or specific conformity to reason), nor, apart from electricity and gravity, to its particular facility, but on the contrary, to the circumstance that the Newtonian law of attraction, in contradiction to the opinion of its discoverer, has so far been considered to need no further explanation.‡

#### I. Laws of motion of the substance that, according to our assumption, causes the phenomena of gravitation and light.

Expressing the position of a point in space by means of rectilinear coordinates  $x_1, x_2, x_3$ , I designate the velocity components—parallel to the coordinates at time  $t$ —of the motion that causes the gravitational phenomena as  $u_1, u_2, u_3$ , and those of the motion that causes the phenomena of light as  $w_1, w_2, w_3$ , and those of the actual motion as  $v_1, v_2, v_3$ , so that  $v = u + w$ . As will emerge from the laws of motion themselves, the substance, if it is everywhere equally dense at one point in time, maintains this same density everywhere at all times. I will therefore assume this to be everywhere equal to 1 at time  $t$ .

§ [In English] Newton says: "That gravity should be innate, inherent, and essential to matter, so that one body may act upon another at a distance through a vacuum, without the mediation of anything else, by and through which their action and force may be conveyed from one to another, is to me so great an absurdity, that I believe no man who has in philosophical matters a competent faculty of thinking can ever fall into it." See the third letter to Bentley.

### a. Motion That Causes Only Gravitational Phenomena.

The gravitational force is determined at every point by the potential function  $V$ , whose partial derivatives  $\frac{\partial V}{\partial x_1}, \frac{\partial V}{\partial x_2}, \frac{\partial V}{\partial x_3}$  are the components of the gravitational force, and this  $V$  is in turn determined through the following conditions (disregarding an additional constant):

1.  $dx_1 dx_2 dx_3 \left( \frac{\partial^2 V}{\partial x_1^2} + \frac{\partial^2 V}{\partial x_2^2} + \frac{\partial^2 V}{\partial x_3^2} \right)$  outside the attracting body = 0, and has for every ponderable material element a constant value. This is the product of  $-4\pi$  in the absolute magnitude of the attractive force, which according to the theory of attraction must be assigned to it, and will be designated as  $dm$ .

2. If all attracting bodies are within a finite space,  $r \frac{\partial V}{\partial x_1}, r \frac{\partial V}{\partial x_2}, r \frac{\partial V}{\partial x_3}$  at an infinite distance  $r$  from a point in this space are infinitely small.

Now according to our hypothesis,  $\frac{\partial V}{\partial x} = u$  and consequently

$$dV = u_1 dx_1 + u_2 dx_2 + u_3 dx_3.$$

This includes the conditions

$$(1) \quad \frac{\partial u_2}{\partial x_3} - \frac{\partial u_3}{\partial x_2} = 0, \quad \frac{\partial u_3}{\partial x_1} - \frac{\partial u_1}{\partial x_3} = 0, \quad \frac{\partial u_1}{\partial x_2} - \frac{\partial u_2}{\partial x_1} = 0,$$

$$(2) \quad \left( \frac{\partial u_1}{\partial x_1} + \frac{\partial u_2}{\partial x_2} + \frac{\partial u_3}{\partial x_3} \right) dx_1 dx_2 dx_3 = -4\pi dm,$$

$$(3) \quad ru_1 = 0, \quad ru_2 = 0, \quad ru_3 = 0, \quad \text{for } r = \infty.$$

Conversely, the magnitudes  $u$ , if they satisfy these conditions, are equal to the components of the gravitational force. Since the conditions (1) contain the possibility of a function  $U$  from

\* This function  $U$  is therefore given through observation (from relative motions) by means of the general laws of motion, but only without taking account of a linear function of the coordinates, because we can only observe relative motions.

The determination of this function is based on the following mathematical theorem: A function  $V$  of position is determined within a finite space (ignoring a constant) if it is not said to be discontinuous along a surface, and for all of its elements  $\left( \frac{\partial^2 V}{\partial x_1^2} + \frac{\partial^2 V}{\partial x_2^2} + \frac{\partial^2 V}{\partial x_3^2} \right) dx_1 dx_2 dx_3$  at the limit, either  $V$  or its derivative is given for an inward change of position, perpendicular to the limit. Of which it should be noted:

1. If this derivative at the bounding element  $ds$  is designated by  $\frac{\partial V}{\partial p}$ , then in the latter case  $\int \sum \frac{\partial^2 V}{\partial x^2} dx_1 dx_2 dx_3$  must be equal to  $-\int \frac{\partial V}{\partial p} ds$  through the entire space because of its bound; otherwise, in both cases, all of the determining elements can be taken arbitrarily and are therefore necessary to the determination.

2. For a spatial element where  $\sum \frac{\partial^2 V}{\partial x^2}$  becomes infinitely large, the product of the two is to be substituted by  $-\int \frac{\partial V}{\partial p} ds$  in relation to the limit of this element.

3. If  $\sum \frac{\partial^2 V}{\partial x^2}$  has a value other than zero only within a finite space, then the boundary condition can be substituted by the statement that at an infinite distance  $R$  of a point in this space  $R \frac{\partial V}{\partial x}$  becomes infinitely small.

which arises the differential  $dU = u_1 dx_1 + u_2 dx_2 + u_3 dx_3$  and thus the derivatives  $\frac{\partial U}{\partial x} = u$ , and the others then yield  $U = V + \text{constant}$ .\*

### b. Motion that causes only light phenomena.

The motion that must be assumed in empty space for the explanation of the phenomena of light can be considered (following a theorem) as composed of plane waves, that is, of such motions where the form of motion is constant along each plane of a family of parallel planes (wave planes). Each of these wave systems consists then (in accord with observation) of motions parallel to the wave plane that are propagated perpendicular to the wave plane with a constant velocity  $c$  that is the same for all forms of motion (types of light).

If  $\xi_1, \xi_2, \xi_3$  are the rectangular coordinates of a point in space for such a system of waves, the first being perpendicular, the others parallel to the wave plane, and  $\omega_1, \omega_2, \omega_3$  are the components of velocity at this point parallel to the coordinates at time  $t$ , then we have

$$\frac{\partial \omega}{\partial \xi_2} = 0, \quad \frac{\partial \omega}{\partial \xi_3} = 0.$$

According to observation, first

$$\omega_1 = 0,$$

second, the movement is composed of motions with velocity  $c$ , one propagating from the positive side of the wave plane, and one propagating from the negative side. If the velocity components of the first are  $\omega'$  and that of the latter are  $\omega''$ , then the  $\omega'$  remain unchanged if  $t$  increases by  $dt$  and  $\xi_1$  increases by  $c dt$ , and the  $\omega''$  are unchanged, if  $t$  increases by  $dt$  and  $\xi_1$  by  $-c dt$ , and we have  $\omega = \omega' + \omega''$ . From this it follows that

$$\left( \frac{\partial \omega'}{\partial t} + c \frac{\partial \omega'}{\partial \xi_1} \right) dt = 0, \quad \left( \frac{\partial \omega''}{\partial t} - c \frac{\partial \omega''}{\partial \xi_1} \right) dt = 0,$$

$$\frac{\partial^2 \omega'}{\partial t^2} = -c \frac{\partial^2 \omega'}{\partial \xi_1 \partial t} = cc \frac{\partial^2 \omega'}{\partial \xi_1^2}, \quad \frac{\partial^2 \omega''}{\partial t^2} = c \frac{\partial^2 \omega''}{\partial \xi_1 \partial t} = cc \frac{\partial^2 \omega''}{\partial \xi_1^2}$$

and thus

$$\frac{\partial^2 \omega}{\partial t^2} = cc \frac{\partial^2 \omega}{\partial \xi_1^2}.$$

These equations give the following symmetrical results:

$$\frac{\partial \omega_1}{\partial \xi_1} + \frac{\partial \omega_2}{\partial \xi_2} + \frac{\partial \omega_3}{\partial \xi_3} = 0,$$

$$\frac{\partial^2 \omega}{\partial t^2} = cc \left( \frac{\partial^2 \omega}{\partial \xi_1^2} + \frac{\partial^2 \omega}{\partial \xi_2^2} + \frac{\partial^2 \omega}{\partial \xi_3^2} \right),$$

which, expressed in the original coordinate system, become equations of the same form, that is,

$$(1) \quad \frac{\partial \omega_1}{\partial x_1} + \frac{\partial \omega_2}{\partial x_2} + \frac{\partial \omega_3}{\partial x_3} = 0,$$

$$(2) \quad \frac{\partial^2 w}{\partial t^2} = cc \left( \frac{\partial^2 w}{\partial x_1^2} + \frac{\partial^2 w}{\partial x_2^2} + \frac{\partial^2 w}{\partial x_3^2} \right).$$

These equations are valid for every plane wave passing through the point  $(x_1, x_2, x_3)$  at time  $t$  and consequently also for the combined motion of all such plane waves.

### c. Motion that causes both types of phenomena.

From the conditions established for  $u$  and  $w$ , the following conditions follow for  $v$  or laws of motion of the substance in empty space:

$$(I) \quad \frac{\partial v_1}{\partial x_1} + \frac{\partial v_2}{\partial x_2} + \frac{\partial v_3}{\partial x_3} = 0,$$

$$\left( \partial^2 t - cc (\partial^2 x_1 + \partial^2 x_2 + \partial^2 x_3) \right) \left( \frac{\partial v_2}{\partial x_3} - \frac{\partial v_3}{\partial x_2} \right) = 0$$

$$(II) \quad \left( \partial^2 t - cc (\partial^2 x_1 + \partial^2 x_2 + \partial^2 x_3) \right) \left( \frac{\partial v_3}{\partial x_1} - \frac{\partial v_1}{\partial x_3} \right) = 0$$

$$\left( \partial^2 t - cc (\partial^2 x_1 + \partial^2 x_2 + \partial^2 x_3) \right) \left( \frac{\partial v_1}{\partial x_2} - \frac{\partial v_2}{\partial x_1} \right) = 0,$$

as is easily derived if the operations are carried out.

These equations show that the motion of a point of the substance only depends on motions in contiguous regions of space and time, and their (complete) causes can be sought in the effects in their neighborhood.

Equation (I) proves our earlier assertion that the density of the substance remains unchanged during its motion; since

$$\left( \frac{\partial v_1}{\partial x_1} + \frac{\partial v_2}{\partial x_2} + \frac{\partial v_3}{\partial x_3} \right) dx_1 dx_2 dx_3 dt,$$

which as a result of this equation is equal to 0, expresses the mass of the substance which flows into the spatial element  $dx_1 dx_2 dx_3$  in time element  $dt$ , and the mass of the substance contained in it therefore remains constant.

Conditions (II) are identical with the condition that

$$\left( \partial^2 t - cc (\partial^2 x_1 + \partial^2 x_2 + \partial^2 x_3) \right) (v_1 dx_1 + v_2 dx_2 + v_3 dx_3)$$

be equal to a complete differential  $dW$ . Now

$$\left( \partial^2 t - cc (\partial^2 x_1 + \partial^2 x_2 + \partial^2 x_3) \right) (w_1 dx_1 + w_2 dx_2 + w_3 dx_3) = 0$$

and consequently

$$dW = \left( \partial^2 t - cc (\partial^2 x_1 + \partial^2 x_2 + \partial^2 x_3) \right) (u_1 dx_1 + u_2 dx_2 + u_3 dx_3)$$

$$= \left( \partial^2 t - cc (\partial^2 x_1 + \partial^2 x_2 + \partial^2 x_3) \right) dV$$

or, since  $(\partial^2 x_1 + \partial^2 x_2 + \partial^2 x_3) dV = 0$ ,

$$= d \frac{\partial^2 V}{\partial t^2}.$$

### d. Common expression for the laws of motion of the substance and the effect of gravity on the motion of ponderable bodies.

The laws of these phenomena can be summed up by the condition that the variation of the integral

$$\frac{1}{2} \int \left[ \sum \left( \frac{\partial \eta_i}{\partial t} \right)^2 - cc \left[ \left( \frac{\partial \eta_2}{\partial x_3} - \frac{\partial \eta_3}{\partial x_2} \right)^2 + \left( \frac{\partial \eta_3}{\partial x_1} - \frac{\partial \eta_1}{\partial x_3} \right)^2 + \left( \frac{\partial \eta_1}{\partial x_2} - \frac{\partial \eta_2}{\partial x_1} \right)^2 \right] dx_1 dx_2 dx_3 dt \right]$$

$$+ \int V \left( \sum \frac{\partial^2 \eta_i}{\partial x_i \partial t} dx_1 dx_2 dx_3 + 4\pi dm \right) dt$$

$$+ 2\pi \int dm \sum \left( \frac{\partial x_i}{\partial t} \right)^2 dt$$

becomes zero under appropriate boundary conditions.

In this expression, the first two integrals extend over the entire geometrical space, the latter over all elements of ponderable bodies, but the coordinates of every element of ponderable bodies are to be so determined as functions of time, and  $\eta_1, \eta_2, \eta_3, V$  as functions of  $x_1, x_2, x_3$  and  $t$ , that a variation satisfying their boundary conditions produces only a variation of the second order of the integral.

Then the quantities  $\frac{\partial \eta_i}{\partial t}$  ( $=v$ ) are equal to the velocity components of the motion of the substance and  $V$  is equal to the potential at time  $t$  at point  $(x_1, x_2, x_3)$ .

#### Translator's Notes

1. The German expression is *Geistesmasse*. It had earlier appeared in the correspondence between Schiller and Goethe (personal communication of George Gregory).
2. The expression *form of motion (Bewegungsform)*, which begins to appear here early in the fragments, appears as "forms of motion (types of light)" in one late occurrence in which the subject is electromagnetic radiation. This suggests that *form of motion* refers to wavelength or frequency.
3. In the fragments on psychology and metaphysics, Riemann refers to the *Erdseele*. The literal translation is *earth mind* or *earth soul*. We have instead used the expression *biosphere*. It will be helpful to the reader to keep in mind all the possibilities suggested by biosphere, earth mind, and earth soul, in the four instances where *biosphere* appears in the translation. The German *Seele* (soul or mind) is the equivalent of the Greek *psyche*. The Greek word also carries the meaning, *that which enables life*. In his *Harmonices Mundi*, Kepler used *anima*—the nearest Latin equivalent of *psyche*—as a metaphor for universal gravitation. The translator thanks George Gregory for these observations on the Greek and Latin terms and their use.
4. See the first of the three paragraphs marked "1" immediately preceding, which begins "1. The higher . . ."
5. The German word is *Denkprozess*.
6. Not the paragraphs 2. and 3. immediately preceding, but the earlier pair following the paragraph that reads, "Empirically, the external conditions of living processes in the range of phenomena accessible to us are."
7. "Characteristics of mind" is used for *Beseeltheit*.
8. Here Riemann addresses the question of the space-filling substance, which he also calls "the aether" in one instance. In this translation, it is also referred to in the expression "particle of substance," and sometimes as simply "substance," after the concept of space-filling substance has been introduced. These expressions for space-filling substance are thus distinct from "ponderable atoms," "ponderable mass," or "ponderable bodies."
9. The question mark and both pairs of parentheses appear in the German without explanation. Are they Riemann's marks, or do they indicate an uncertain reading of the manuscript?



# Tokamak Plasma Advances Made, But Budget Cuts Threaten Program

by Mark Wilsey

Recent experiments with the two large U.S. tokamaks have produced marked improvements in plasma confinement and plasma densities—the kinds of developments that could have a significant impact on the size and cost of future fusion power plants. However, a short-sighted Congress has threatened any further progress in fusion by slashing the fusion budget by 30 percent and cancelling the next-generation fusion device, the TPX, or Tokamak Physics Experiment.

Scientists have striven for decades to harness fusion energy as an economical, plentiful energy source. But although fusion energy powers the Sun and stars, creating the same conditions here on Earth has been an elusive goal. The experiments with the General Atomics Doublet tokamak, the DIII-D (pronounced “dee-three-dee”) in San Diego and with the Tokamak Fusion Test Reactor (TFTR) at the Princeton Plasma Physics Laboratory in New Jersey have now given us a glimpse of a new physics regime.

## Reversed Shear

The technique used at Princeton and General Atomics to improve confinement and plasma stability is called reversed shear. In both tokamaks, reversed shear was achieved by adjusting the magnetic fields to maximize the electrical current density profile of the plasma, *off-center*. In typical tokamak operations, the peak is at the center of the plasma. The result of this off-center peak is, in effect, a partitioning of the plasma into a highly stable “core” region and a surrounding “mantle.”

Magnetic fusion research in the 1970s included a broad range of experimental approaches designed to utilize the natural geometries of plasmas in order to promote the conditions necessary for fusion. As the overall fusion budget was cut, the funds for these alternative programs were cannibalized in favor of the

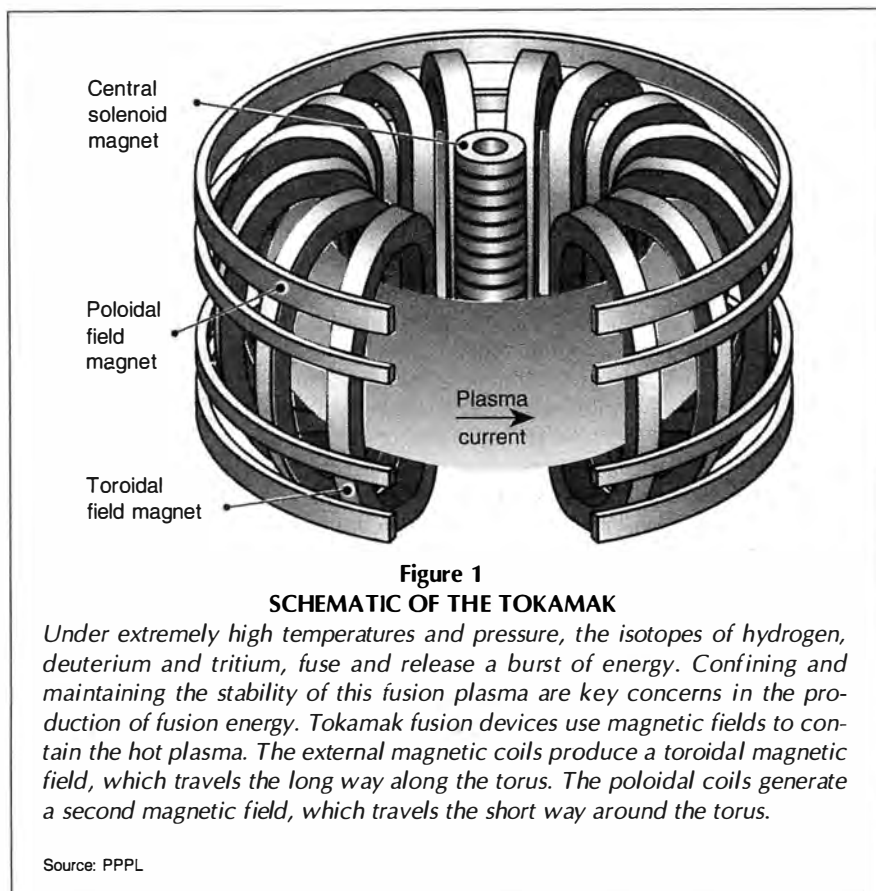

**Figure 1**  
**SCHEMATIC OF THE TOKAMAK**

*Under extremely high temperatures and pressure, the isotopes of hydrogen, deuterium and tritium, fuse and release a burst of energy. Confining and maintaining the stability of this fusion plasma are key concerns in the production of fusion energy. Tokamak fusion devices use magnetic fields to contain the hot plasma. The external magnetic coils produce a toroidal magnetic field, which travels the long way along the torus. The poloidal coils generate a second magnetic field, which travels the short way around the torus.*

Source: PPPL

brute-force collisional approach—adopted by Princeton—in the form of scaling up the tokamak. Ironically, scientists there have now “discovered” the kind of self-organized geometry that was central in the work of such scientists as Winston Bostick, Daniel Wells, and Bruno Coppi.

At Princeton, in tests run in spring 1995 on the TFTR, particle confinement improved by a factor of 40, with core plasma density boosted by a factor of 3 over conventional operations. At General Atomics, experiments conducted in 1994 on the DIII-D showed a marked improvement in plasma confinement and plasma densities. Both research

groups have submitted papers to *Physical Review Letters*.

Charles Kessel, a physicist at Princeton whose theoretical work aided the success there, notes how reversed shear yields distinct improvements: The partition acts to suppress particle and energy transport out of the plasma; this improves confinement, which then leads to higher densities and temperatures in the core. In addition, the current induced in the plasma reinforces the current generated by the plasma itself. With the TFTR, it can generate as much as 80 to 90 percent of its own current.

The self-generated current in the plasma is called the “bootstrap current,”

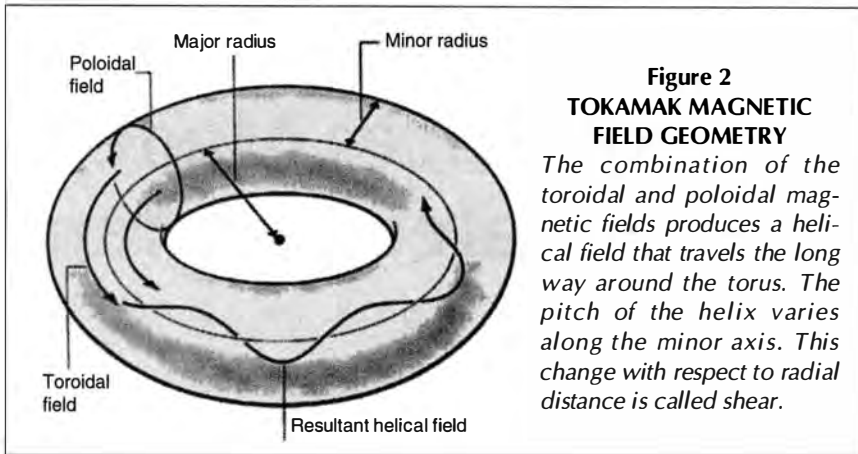

**Figure 2  
TOKAMAK MAGNETIC  
FIELD GEOMETRY**  
*The combination of the toroidal and poloidal magnetic fields produces a helical field that travels the long way around the torus. The pitch of the helix varies along the minor axis. This change with respect to radial distance is called shear.*

and fusion researchers are hopeful that it can be employed in future fusion devices to extend experiments for several minutes, or perhaps indefinitely. Now, machines can operate only in pulses of a few seconds at best.

**The Budget Axe**

Reversed shear, as well as other advanced tokamak concepts, can be completely demonstrated only in a continuous operation, steady-state machine. This was the role that TPX was to have played in the U.S. fusion program. But now this next-generation device has been slashed out of the budget.

The fusion funding provision for fiscal year 1996 passed by Congress is \$244 million—a sharp reduction from this year’s \$349 million and more than 33 percent below the \$366 million requested by the administration.

TFTR was to have been shut down this year to make way for TPX. But with the cancellation of TPX and the reduced funding, Princeton has been forced to lay off a third of its fusion staff, some 240 employees, and it is not clear whether TFTR will be allowed to operate next year. Indeed, the continued operation of other fusion facilities is also threatened by such reduced funds.

Unless the low funding levels are reversed, it seems unlikely that the United States will be able to maintain a fusion program. Of real concern is not simply that the nation will no longer invest the funds to keep its present fusion machines run-

ning, but that the United States will not have scientists and engineers capable of continuing the quest for fusion energy.

**The Beta Limit**

It was in part out of the design studies for the now-cancelled TPX that Charles Kessel and his Princeton colleagues began investigating the reversed shear approach for tokamak operations. The TPX was planned to operate in steady-state mode for pulse lengths of up to 1,000 seconds.

General Atomics came to investigate reversed shear as part of a range of advanced tokamak physics concepts being explored on the DIII-D. Tony Taylor, a scientist at General Atomics who has been involved in this work since 1991, explained that the object is to use the best physics we know to bring new ap-

proaches to tokamak power plant design. The approach taken at General Atomics has been to use reversed shear to change the current profile in the plasma to improve what is called the beta limit.

Beta is the ratio of the plasma pressure at the center to the magnetic pressure being applied to the tokamak, and can be thought of as a measure of how well the device is able to confine the plasma. As the pressure builds up, instabilities occur in the plasma that let the pressure out. Hence, the plasma reaches its stability limit, or beta limit.

The achievement of higher densities leads to increased fusion reactivity. Researchers at Princeton are confident that it may now be possible to double TFTR’s output, from 10 megawatts, its record set in 1994, to 20 MW or higher, using deuterium-tritium fuel. So far, experiments have been conducted only with deuterium.

**Tokamak Physics**

Tokamaks are toruses, that is, shaped like donuts (Figure 1). External magnetic coils placed around the tokamak produce a toroidal magnetic field, which travels the long way along the torus. The toroidal field induces a current in the plasma which, in turn, generates a second magnetic field, the poloidal field, which rotates about the centerline of the torus. Still other magnets are used to augment and control

this current. The combination of the toroidal and poloidal fields defines the magnetic fields inside the plasma; these are helical in shape, going around the length of the torus (Figure 2).

The twist of the helix changes within the plasma as a result of the increasing strength of the poloidal field toward the centerline of the torus. The helix tends to become more tightly twisted toward the center. The change in its twist (pitch) as one moves inward along the minor axis is called “shear.”

In reversed shear, the field lines increase in twist up to a point, and then decrease. In the TFTR, that point was found roughly one-third of the way out from the center. This is the point at which the

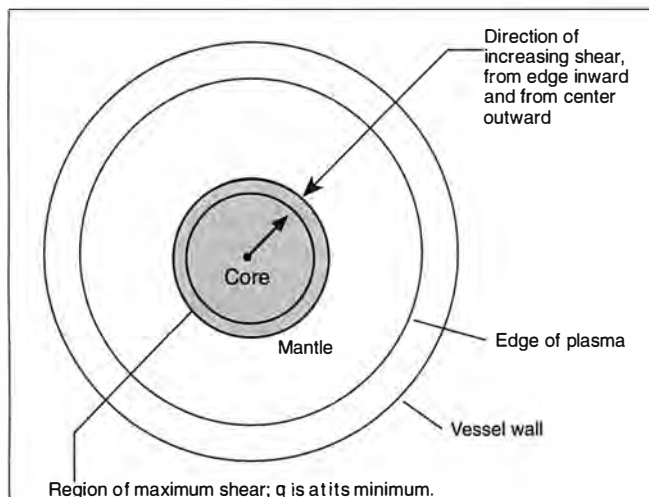

**Figure 3  
REVERSED SHEAR IN THE PLASMA CROSS SECTION**  
*In the reversed shear mode, the magnetic shear within the plasma increases from the edge inward, as well as from the center outward. The core region is highly stable.*

plasma is divided into the core and mantle regions (Figure 3).

The beta limit is expected to increase in this process. As Tony Taylor explains it, normally the magnetic fields within the plasma are crossed, as the twist changes toward the center. Then as the pressure is increased, these fields are pushed out from the core and start to line up, at which point, the plasma becomes unstable. With reversed shear, however, the field lines are crossed in such a way that they do not line up again, thus avoiding instabilities and increasing the beta.

Another way to look at it, is in terms of what is called the safety factor, or  $q$ , which measures the magnetic twist by the number of laps that the field lines make around the torus the long way before they make one turn the short way. A lower  $q$  means a higher twist, showing that it takes fewer laps around the torus to make one twist.

A plot of the safety factor,  $q$ , versus distance along the radius for a reversed shear mode will show a characteristic  $W$ -shaped curve (Figure 4). The peak of the  $W$  is in the center of the core. The low points on either side of the core are the points at which the shear reverses, changing directions. By contrast, in the more typical tokamak operation, the  $q$  profile would be more  $U$ -shaped toward the center; that is, the  $q$  constantly decreases, or the twist of the magnetic field constantly increases.

The  $W$ -shaped  $q$  profile is accomplished by ramping up the current in the plasma while simultaneously heating the core. Continuously changing the current in the magnetic field coils induces a current in the plasma. The current in the plasma tends to start at the edge and diffuse toward the center. The time that it takes for the current to diffuse is a function of the plasma temperature. So, by heating the plasma, using neutral beams, that time can be stretched out. The heating of the plasma retards the current penetration to produce an off-center peak.

Princeton and General Atomics use similar approaches for reversed shear experiments, except that the DIII-D has a D-shaped cross-section, while the TFTR's cross-section is circular. GA researchers have also achieved reversed shear in three different operating modes with the DIII-D, one of which is very similar to that of the TFTR, and two others that are

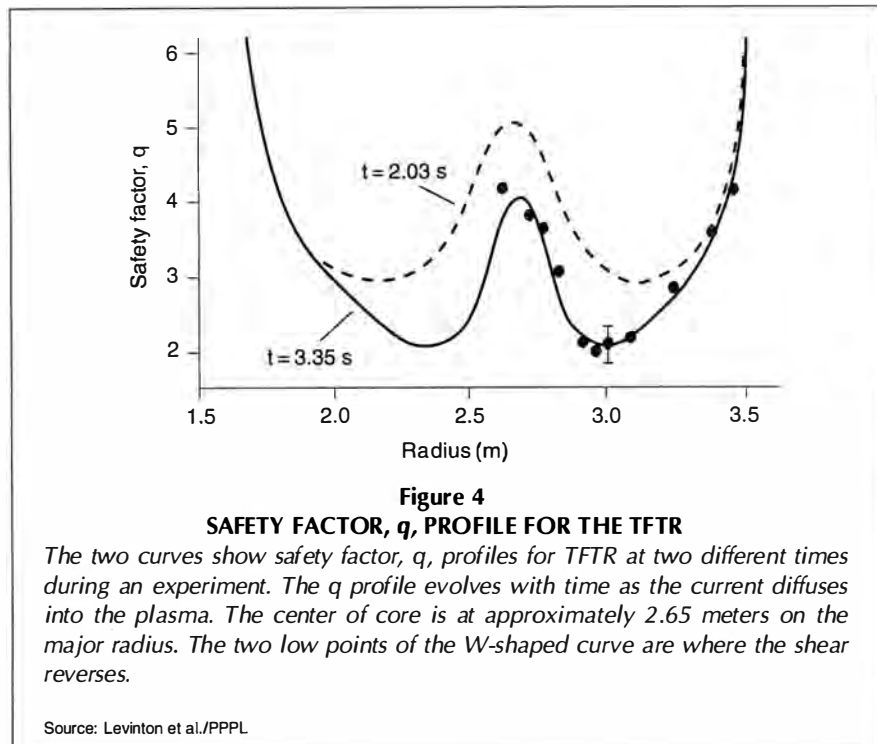

in "high mode," or "H-mode," meaning that the conditions at the edge of the plasma tend to also reduce transport, and thus improve confinement.

To date, neither TFTR nor DIII-D has actually shown marked improvements in beta (the ratio of plasma pressure to magnetic pressure) in these reversed shear experiments. A doubling of the beta values over conventional operations is the payoff that the researchers are looking for. Taylor thinks that the broader plasma pressure profile of the H-mode reversed shear may be a more productive route to higher beta values.

#### Implications

GA's Tony Taylor cautioned against overestimating the importance of these reversed shear results. While he is excited by them, he realizes that there is still much work ahead to prove out this approach. Still, these results do demonstrate that there is a great deal of interesting physics to be explored.

Princeton has shown on paper that based on a reversed shear mode, researchers should be able to at least double the output of TFTR, and perhaps even achieve breakeven. This would mean achieving very high beta values, which remains a significant challenge.

Looking farther into the future, Princeton's Charles Kessel has begun to examine what reversed shear could mean for

a future fusion power plant. The design work on TPX supported the idea that a steady-state reactor would be four times smaller in size than a pulsed reactor, based on current designs. Kessel has found that when the reversed shear is applied to the operations of a steady-state reactor, the size and cost of plant is reduced yet another 50 percent.



## LaRouche Campaign Is On the Internet!

Lyndon LaRouche's Democratic presidential primary campaign has established a World Wide Web site on the Internet. The "home page" brings you recent policy statements by the candidate as well as a brief biographical resumé.

TO REACH

the LaRouche page on the Internet:

<http://www.clark.net/larouche/welcome.html>

TO REACH

the campaign by electronic mail:

larouche@clark.net

Paid for by Committee to Reverse the Accelerating Global Economic and Strategic Crisis: A LaRouche Exploratory Committee.

IN THE FOOTSTEPS OF KEPLER

# A Master Polyhedra Builder Demonstrates His Art

by Charles B. Stevens

One of the world's leading constructors of polyhedra, Father Magnus J. Wenninger, visited *21st Century* in August to display some of the models (shown here and on the covers) and talk about the method of construction. Wenninger is a Benedictine monk and a retired high school mathematics teacher, who has written the three leading works on construction of polyhedral models: *Polyhedron Models*, *Spherical Models*, and *Dual Models*. All are published by Cambridge University Press.

Wenninger was the first to construct models of the set of 75 uniform polyhedra—solids that had been derived from Kepler's specifications for expanding the set of regular and semiregular solids—and the first to discover and construct the complete set of their duals. His method appears in his book *Dual Models*, published in 1983.

Father Wenninger's visit was well timed—1996 is the 400th anniversary of the publication of Kepler's first major work, *Mysterium Cosmographicum*, and his work is a direct continuation of Kepler's study of geometry.<sup>1</sup>

### Stellations and Duals

As Father Wenninger indicated in his presentations, the ancient texts were lost and, therefore, Johannes Kepler was the first to present a complete description of the 5 regular Platonic solids and the 13 semiregular Archimedean solids, which he did in his *Harmonices Mundi* (1619). Kepler also significantly extended the concept of regular and semiregular solids, and generated two new families of solids based on stellation and creation of dual solids.

He was the first to rigorously develop the concepts of how to generate these

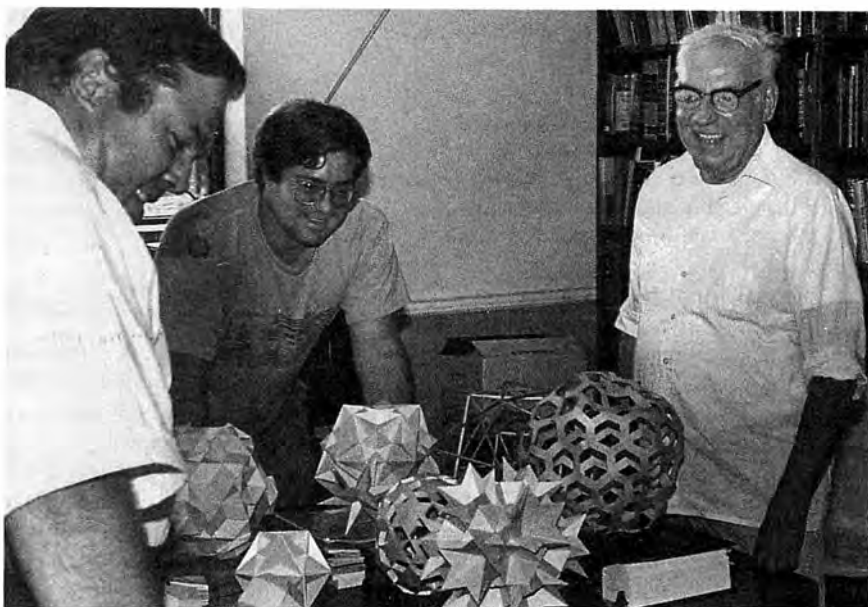

Elijah C. Boyd

Father Magnus J. Wenninger (right) with Charles Stevens (left) and Rogelio Maduro, surveying some of the polyhedral models Wenninger presented to *21st Century*.

polyhedral stellations and duals. Stellations, according to Kepler, derive from the extension out into space of the face planes of the original solid, which are star-like in shape. Duals are determined by placing a point in the center of each face of a polyhedron and connecting them to form a new solid. The tetrahedron, for example is its own dual, while the cube and the octahedron are duals.

Kepler's *stella octangula* involves both concepts. It is the figure comprised of the two tetrahedra that are seen within a cube and share its eight vertices. These two tetrahedra are duals of each other. Also, the total configuration is the first—and last—stellation of the octahedron.

The *stella octangula* is also the beginning of an entirely new family of polyhedra—star polyhedra—that have interpenetrating faces. (It can be called the zero'th star polyhedron; it generates the

family although it is not itself formally a star polyhedron.)

Further developing the geometric methods exhibited with the *stella octangula*, Kepler elaborated the stellations of the dodecahedron. This provided the basis for extending the series of regular Platonic solids; that is, incorporating star polygons among the set of regular polygons leads to seven new regular star polyhedra. And, in fact, Kepler was the first to construct two new regular polyhedra, each having 12 star pentagram faces: the small and great stellated dodecahedra.

Applying the same methods to the semiregular Archimedean polyhedra leads to 53 new polyhedra that have faces consisting of a combination of regular and star polygons. The full set of regular and semiregular polyhedra are today called the uniform polyhedra.



In the 1930s, geometers, led by H.M.S. Coxeter, elaborated the set of 59 icosahedral stellations that maintained the full rotational degrees of freedom of the dodecahedron.

It was not until the 1950s, that a full set of uniform polyhedra, based on Kepler's original specifications, was found. Wenninger was the first to construct models of this full set of these uniform polyhedra. He then discovered and constructed their duals.

### Toward New Regular Polyhedra

Wenninger is continuing to explore these basic geometric methods of Kepler by extending the notion of regular polyhedra. He is doing this primarily by further elaborating the stellation process.

Besides stellating the regular Platonic solids, it is also possible to stellate the semiregular Archimedean and their duals. Work on exploring these stellation possibilities is still only at a preliminary stage. Research on this has led to new types of regular polyhedra.

For example, some stellations of Archimedean duals have features in common with regular polyhedra: All vertices are the same and the solid is made with all the same kinds of polygonal face. But, the polygon face is no longer a regular polygon, and it is not necessarily two-sided—that is, the polygon face can be "crossed" and one-sided like a Möbius strip.

This new type of regular polyhedron has significant implications for advanced applications to topology, elliptic modular functions, and analytic number theory.

### Perfect Polyhedra

A second new class of polyhedra deriving from this research is the perfect polyhedra. These have arisen out of the research on uniform polyhedra. Many of the uniform polyhedra have casings in which the vertices are the same as one of the 13 Archimedean. (The casing of a solid is another solid made by connecting the vertices of the first.) In some cases the vertices are slightly distorted. For example, what would be the vertices of a square become the vertices of a rectangle, in terms of the casing.

These casings represent examples of "perfect" polyhedra. The polygons used to make them are no longer regular in that they use more than one edge length, usually two different lengths that are in golden proportion to one another.

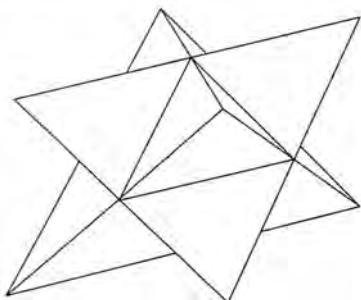

Figure 1

### KEPLER'S STELLA OCTANGULA

*As elaborated by Father Wenninger, most of the conceptual framework for the stellation and dual-generating processes is contained in Kepler's construction of his stella octangula, literally a stellated octahedron, as shown here.*

*The octahedron is the Platonic solid with eight triangle faces, and it is also the dual of the cube. That is, if we place a point in the center of each face of the octahedron and connect them to form a new solid, we will have the eight-cornered cube. In the same way, we could place a point in the center of each of the six squares of the cube and connect them to generate the octahedron. Kepler's stella octangula is both a stellation of the octahedron and a representation of two dual tetrahedra.*

Despite the deep mathematical implications of Father Wenninger's work, he has always carried out his work in a form that is accessible to high school students.

Collaboration with Wenninger and his colleagues has already led to major new discoveries in the nested Platonic solids model for the atomic nucleus created by the late Dr. Robert Moon of the University of Chicago, and discoveries in the field of polyhedra.<sup>2</sup>

For example, Christine Tuveson, a leading collaborator of Wenninger, has discovered that the Moon Model specification already contains a compound of 20 cubes and the Gauss Golden *Pentagramma Mirificum*. The 20-cube compound is a focus of Wenninger's current research and is at the forefront of polyhedral research in general. A book on the 20 cubes, titled *Symmetry Orbits*,

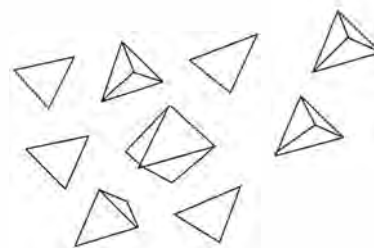

Figure 2

### OCTAHEDRON CORE OF THE STELLA OCTANGULA

*The removal of the eight tetrahedral cells of the stella octangula to reveal the octahedron core of the stellation.*

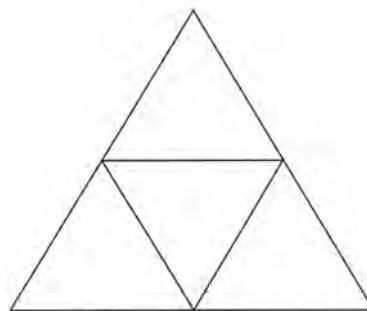

Figure 3

### STELLATION NET OF THE OCTAHEDRON

*The six intersections of face planes to form the stellation net of the octahedron.*

will be published early next year. It has also been determined recently that the star polyhedra lead to a set of 12 regular polyhedra.

When constructing the vertices for the duals of Archimedean and uniform polyhedra, which have more than one face type, the face center must be inverted with respect to the sphere circumscribing the original polyhedron.

### Constructing Stellations

One way to construct the *stella octangula* is to take eight tetrahedra—the Platonic solids with four triangle faces—and place each on the face of an octahedron. This generates eight star points, as seen in Figure 1. The eight tetrahedra have been removed to reveal the octa-

hedron core of the stella octangula in Figure 2.

Many people before Kepler had tried to generate new polyhedra by adding arbitrary pyramids to the Platonic and Archimedean solids, but Kepler was the first to rigorously specify how stellations are generated from the original base polyhedron. The stellations, according to Kepler, derive from the extension out into space of the face planes of the original solid. For example, there are three faces adjacent to one face on an octahedron. If we extend the planes of these three faces over the one face, they will intersect to generate a three-faced pyramid, which, together with the one face, forms a closed cell.

In this case, the closed cell is actually a small tetrahedron. When this is done for each of the eight faces of the octahedron, eight cells (eight tetrahedra) are generated, and the stellation is the *stella octangula*.

For solids with more faces than the octahedron, like the dodecahedron, more than one layer of closed cells in space can be generated by the extension of the solid's face planes. (For the dodecahedron, three cell layers are generated, each of which in turn constitutes a stellation of the dodecahedron.)

#### The Stellation Net

For constructing a model of a stellation, the crucial thing to know is the number and shape of all of the facets that appear on the outside of the stellation. To obtain this information, we must

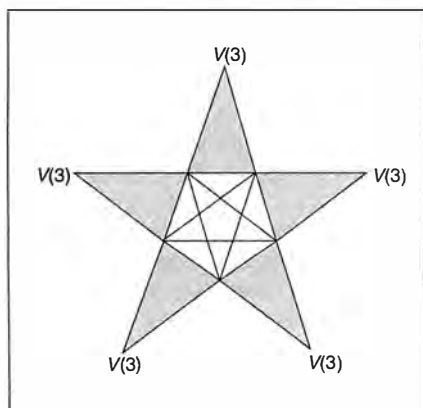

**Figure 4**  
**STELLATION NET OF THE DODECAHEDRON**

*The stellation net of the dodecahedron from which all stellation nets can be synthetically derived.*

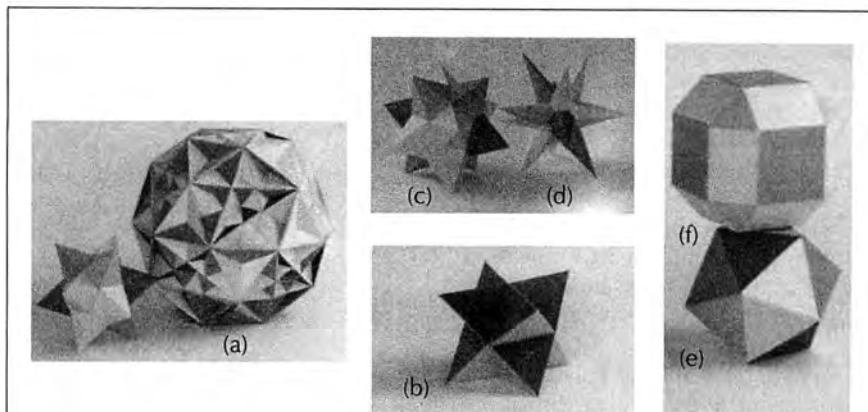

#### Illustrations on the Covers

##### Front cover:

(a) An example of a perfect polyhedron with the vertices of the Archimedean icosadodecahedron, which has 30 rectangular faces and 20 perfect hexagons. With it is a small stellated dodecahedron.

##### Back cover:

(b) Kepler's *stella octangula*, which is both the first and last stellation of the octahedron and a compound of two tetrahedra.

(c) The small stellated dodecahedron.

(d) The ninth stellation of the icosahedron is the dual of two different polyhedra—with hidden vertices: the medial triambic icosahedron and the great triambic icosahedron.

(e) The icosahedron.

(f) The small rhombicuboctahedron is a perfect version of the Archimedean solid. It has 12 rectangles and 6 squares, together with 8 triangles, instead of 18 squares and 8 triangles in the regular version.

generate the stellation net. This is actually a cross section of the nesting of cells generated by the extension of the solid's face planes through space. That is, we look at how all the solid's face planes intersect one particular face plane.

Take an octahedron and place it face down on a piece of paper. If we use a stiff piece of cardboard, we can extend the planes of six of the seven remaining triangle faces of the octahedron to see how they intersect the piece of paper. (The seventh face is parallel to the eighth one on the paper, so its extension never intersects the paper.)

The six lines of intersection of face planes with the face on the paper are shown in Figure 3. This is the stellation net of the octahedron, an equilateral triangle inscribed in an equilateral triangle. The inner triangle is the face of the octahedron. To make the *stella octangula*, one must make the three outer triangles eight times, or 24 triangles in all.

Figure 4 shows the stellation net for the dodecahedron, which is a pentagram

inscribed within a pentagram. Outside of the original pentagonal face of the dodecahedron, there are three layers of cells. Can you find them?

For polyhedra with more faces (and therefore more face planes to intersect in space), the stellation nets become quite complex. And the number of possible stellations grows to astronomically large numbers—for example, more than all the electrons currently thought to exist in the universe.

During Wenniger's visit to *21st Century*, a new method for generating stellation nets was discovered, one which makes use of the pentagram method of Leonardo da Vinci and Kepler. In outline, the method derives all stellation nets from the pentagram net of the dodecahedron through the use of Jacob Steiner's synthetic geometry.

#### Notes

1. A feature article on Kepler's *Mystery of the Universe* appears on page 22.
2. For more on the Moon model, see Laurence Hecht, "Mysterium Microcosmicum: The Geometric Basis for the Periodicity of the Elements," *21st Century*, May-June 1988, p. 18.

## SAVING THE OLIGARCHS

# The Real Agenda Behind the Greens

by Rogelio A. Maduro

## Cloak of Green

Elaine Dewar

Toronto: James Lorimer & Co., 1995

Paperback, 497 pages, U.S. \$22.95

**C**loak of Green, by one of Canada's leading investigative journalists, is a devastating exposé of the shady finances of the international environmental movement, its dirty operations, and, most important, the role of multinational corporations and the European nobility in directing the actions of the movement. The book demonstrates the interlocking components of the international environmental movement, and questions on whose behalf this network is operating.

Author Elaine Dewar spent more than five years amassing a mountain of evidence, which she presents in a very readable narrative, almost like a detective novel. In her own way, Dewar corroborates many of the charges made in the October 1994 special report, "The Fall of the House of Windsor," published by the political weekly *Executive Intelligence Review* and written under the direction of Lyndon H. LaRouche, Jr.\*

*Cloak of Green* begins in November 1988 at a fundraiser "to save the Amazon rainforest," co-sponsored by the World Wildlife Fund in Canada. More than 2,000 people gathered to hear Paulinho Paiakan, an Indian chief from the Kayapo tribe in the Amazon. The Brazilian government was planning to build dozens of dams in the Amazon, the public was told, plans that not only would destroy the Amazon but would affect the global climate.

Dewar attended the fundraiser because she was "deeply worried" that "[f]looding huge tracts of Amazon rainforest would be the atmospheric equivalent of the straw that broke the camel's back."

She describes the fundraiser as a stirring event. Paiakan vividly told of his people's fight against the rapacious gold miners and timber barons who were trying to rape the Amazon. The response from the audience, mostly Yuppies, was to crowd the large number of fundraising tables and contribute to the cause.

Dewar became so interested in the issue that she decided to follow it up by writing a series of articles. In July, she attended a Sierra Club International Conference in Minnesota where Paiakan was receiving a prize for his work in preserving the rainforest. It was during this meeting that the green propaganda facade began to fall apart.

It started when some in the audience confronted Paiakan with the fact that the Kayapo, the "Defenders of the Rainforest," were actually selling gold mining and logging concessions to multinational corporations. Paiakan told Dewar that that the charges were true, but that the Kayapo's aim was to control the extent of the exploitation!

Later, at a press conference, when Paiakan was asked for what the money being raised for the Kayapo by the Sierra Club was being used, he said that he didn't know. The Kayapo had not seen any of it, he replied.

Two days later, Dewar met Paiakan in Toronto, where he had been invited by Adam Zimmerman, chairman of the Canadian branch of Prince Philip's World Wildlife Fund. Zimmerman gave a reception for Paiakan at his home, where the Kayapo chief was staying. This seemed odd, Dewar says, because "Zimmerman was then president of Noranda Forest Products, which then controlled MacMillan Bloedel and other forest companies. Noranda Forest Products was itself a subsidiary of Noranda, Inc., a multinational mining and forest prod-

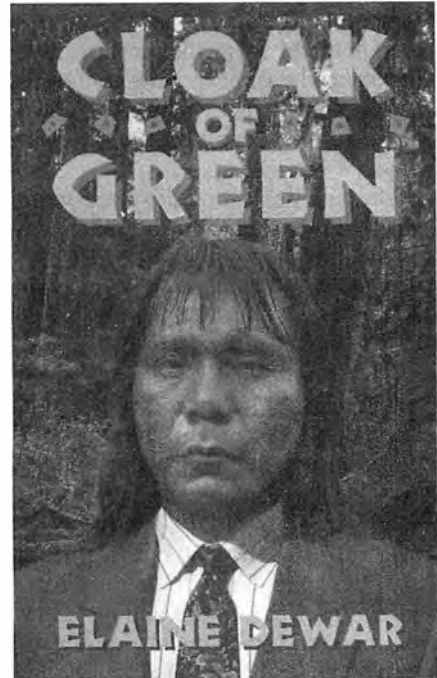

ucts holding company, which was in turn controlled by Brascan, a holding company prominent in the empire of Sam Bronfman's nephews, Edward and Peter Bronfman."

At the time, Brascan was considered the number one destroyer of the Amazon rainforest!

But Zimmerman was not the only magnate present. The heads of Canada's largest corporations had gathered to pay homage to Paiakan. "As the living room filled with guests," she writes, "my notebook filled with the names of the rich, the powerful, and the well known."

### Saving the Oligarchs

Why were some of the richest and most powerful figures in the world supporting this Amazon Indian's campaign? At this point, Dewar decided to uncover the real story. She traveled to Brazil,

*Continued on page 71*

# Another Biased Account of Cold Fusion

by Dr. Edmund Storms

---

## A Dialogue on Chemically Induced Nuclear Effects: A Guide for the Perplexed about Cold Fusion

Nate Hoffman

La Grange Park, Ill.:

American Nuclear Society, 1995

Cloth, 223 pages, \$30.00

---

To a casual reader, Nate Hoffman's book might seem like an objective and balanced treatment of the controversial phenomenon conventionally known as cold fusion. Unfortunately, this impression is very wrong.

Sadly, the book provides even more confusion than found in the other two recent efforts to kill the field: John Huizenga's *Cold Fusion: The Scientific Fiasco of the Century* and Gary Taubes's *Bad Science: The Short Life and Weird Times of Cold Fusion*. At least each of these two books leaves the reader with no doubt about the author's bias!

Everyone, skeptic and believer alike, agrees that many questions need answers and that experimental error exists in many studies. However, the public would be better served if skeptics used the same respect for truth and logic that they demand of those who support research in the field of cold fusion. This respect for truth is frequently absent in Hoffman's book.

Hoffman starts off well by giving a good assessment of how the cold fusion field fell into such disrepute and by providing a wealth of unpublished experimental data. He also provides an understanding of how the negative attitude developed and was reinforced by the leadership of the electric utilities' think tank, the Electric Power Research Institute (EPRI). As an example of this, EPRI's Thomas Schneider concludes in the book's foreword that because neutrons or other expected nuclear products are not observed in cold fusion experiments, no energy production by nuclear means is possible; hence "cold fusion" cannot be real.

The rest of the book is designed to provide supporting evidence for the negative viewpoint expressed by Schneider. Instead, however, the evidence pre-

sented demonstrates that skeptics, including Hoffman, will believe the most unlikely possibilities in order to avoid believing the "cold fusion" effect.

### Explaining Away Tritium

Many examples of this phenomenon are provided, a few of which are especially outrageous. Hoffman attempts to explain away the claims for tritium production by adopting an amazing series of assumptions. He first proposes that commercial heavy water has been contaminated with tritium, uranium-238, and lead-210 as a result of its being mixed with heavy water previously used in nuclear reactors. According to Hoffman, this mixture can account for the observed tritium (and neutrons as well—but that is another story).

The high initial tritium levels could, in Hoffman's view, be the source of the anomalous tritium found in some cold fusion experiments. Should this idea not fly, Hoffman suggests that beta radiation from Pb-210 decay might be mistaken for tritium by careless experimenters. Never mind that all studies of tritium production in cold fusion experiments compare the beta activity before the experiment to the activity resulting from the procedure and use only very-low-tritium water. Tritium is only claimed when this difference changes by a significant amount.

Never mind that Pb-210 is an extremely rare isotope of lead, being produced at a maximum rate of about 3 atoms per minute from 1 gram of U-238. Only a fraction of these atoms would decay during a measurement because Pb-210 has a 21-year half-life. Most U-238 decays to Pb-214, which cannot be mistaken for tritium. Consequently, the decay rate and the total number of offending atoms would be at least 15 orders of magnitude below these quantities when observed during typical tritium measurements.

And finally, Hoffman ignores the fact that commercial heavy water does not contain used nuclear reactor water or any U-238.

All of these facts are easy to check—unless one wants to believe that tritium is

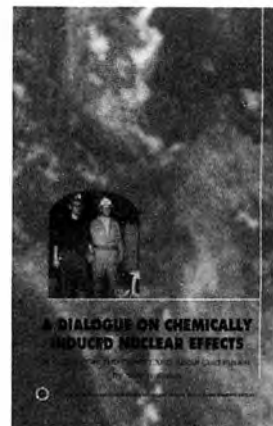

not actually being produced in these cold fusion experiments.

And in case his explanations were not sufficient to convince his readers, Hoffman then applies his imagination with even greater abandon. He assumes that commercial palladium has been contaminated with tritium by being mixed with metal used during the atomic weapons program. Such mixing has been looked for hundreds of times without any evidence being found. However, to be on the safe side, cold fusion researchers use only "virgin" palladium, and most test for tritium before its use.

In addition, palladium known to be contaminated does not release its tritium in the same manner as observed when anomalous tritium is made in the cold fusion experiments. All of these facts totally discredit Hoffman's proposed explanation.

### Intellectual Honesty

Of course, an examination of all wild ideas is necessary and appropriate if we are to understand the amazing effect known as cold fusion. However, when an idea turns out to be ridiculous, intellectual honesty requires this realization to be pointed out. Why must a reader of this book have to contact the suppliers of heavy water and palladium, or look up the decay chain of U-238 to learn the missing facts?

Although some good information is to be found within the nonsense in this book, a reader would have to be more skilled than most to make a proper selection. This is definitely not a "guide for the perplexed about cold fusion" as the subtitle promises.



# The Real Green Agenda

Continued from page 69

Switzerland, and Washington, D.C., to trace the money and uncover who was really behind the campaign to save the rainforests and why.

Dewar discovered that the world of environmental groups and other non-governmental organizations (NGOs) is a small, tightly linked network of individuals. This movement is funded by the world's most powerful families through their family foundations, such as the Ford and Rockefeller Foundations, as well as the world's largest multinational corporations.

As Dewar found out, enormous amounts of money raised to save the rainforest or for other environmental causes, mysteriously disappeared or were used for other purposes. Dewar's painstaking tracking of the movement of money through the foundations, corporations, and green groups, looked like an apparatus modeled after a drug money laundering operation, not a charitable organization.

Dewar shows how the Canadian government plays a major role in laundering this money, as well as providing its own funding and direction to what she calls "the network." She learned that the Canadian International Development Agency (CIDA), the Canadian embassy in Brazil, and other sources were giving large sums of money to a network of environmental organizations and supposedly politically neutral NGOs. As she spells out in detail, these same NGOs then use the money to finance political parties as well as candidates for office, including presidential campaigns.

In addition, many of the NGOs also use the money to impose changes in international policies through the United Nations and through international institutions like the World Bank. All this politicking, of course, is carried out in the name of saving the environment.

As for the "victims" of the exploitation, Dewar discovered that the Kayapo were not concerned about preserving the Amazon! They used the money raised for them by the international green and anthropologist groups—that is, what was left of the money after the fundraisers took their share—and the money from logging and mining conces-

sions, to build luxury air-conditioned villas with servants and to purchase the latest model luxury cars and planes.

## Breaking Up the Nation State

Dewar concluded that the tightly run network she had uncovered had a clear, underlying agenda: to destroy the institution of the nation state, break up sovereign nations, and seize the natural resources from the squabbling tribes that inherit the land.

Her discovery of "the agenda" came in October 1990, at a series of events during Rainforest Week in Toronto. As Dewar recounts it:

Jason Clay of Cultural Survival, Inc. ". . . launched into a treatise favouring the rise of ethnic nationalism as opposed to the nation state. . . . This thesis expressed the real shared vision of those who toiled together in the network—environmentalists, democrats, former Maoists, government officials, corporations, and the politicians in power in certain countries. They did share a very broad common Agenda. . . . [which] was far broader than a global attempt to get environmental issues into the centre of domestic politics. . . . The broad common Agenda aimed to remake the institutions of governance, to lever power up to large multilateral regional institutions while stripping it away from nation states. . . .

"His [Clay's] theme was: the nation state is a corrupt idea with no remaining political legitimacy. The nation state should wither away, its functions replaced by institutions of local and global governance."

The green network, Dewar says, is using the United Nations as a platform to sell the idea of a global environmental crisis as the basis to promote what she terms the Global Governance Agenda. The hidden aim of the Rio Summit in 1992, she says, was to advance the agenda by persuading national governments to cede jurisdiction in key environmental areas to the U.N. bureaucracy.

"By the year 2000," she writes, "there would be few independent national entities left capable of defending local communities" from exploitation by multinational corporations. The argument for this one world government, as Dewar outlines it, is that environmental problems like ozone depletion and global warming are global and require suprana-

tional measures and supranational institutions to be resolved.

Dewar documents how the environmentalists, the United Nations, the NGOs, and Schmidheiny's Business Council on Sustainable Development (representing the multinational corporations) all want to destroy the nation state for their own reasons. These are not competing interests. As Dewar shows, the publicly perceived adversarial relationship between radical green groups and multinational corporations dissolves in the back rooms of the U.N. apparatus in Geneva. These groups not only are tied together, but very often are composed of the same people!

## The Green Prince

The World Wildlife Fund is at the center of Dewar's story. After discussing the role of Prince Philip in setting up the World Wildlife Fund internationally, Dewar describes some of the dirty WWF operations as well as the secrecy that surrounds the leadership:

"There are only 300 true members of WWF Canada. They are drawn from three exclusive groups: the board; the 68 Canadian members of the 1001 Nature Trust; and a donor group called 200 Canadians for Wildlife. . . . [T]he trust [is now] full, but if one were asked to join, the price of entry had already climbed to U.S. \$25,000."

As for the agenda of the WWF, Dewar states:

"The . . . World Wide Fund for Nature, is directed by members of aristocratic families, CEOs of major oil, gas, transport, pharmaceutical, investment, tobacco, and banking interests with strong political connections. [WWF] takes money from people with a need to

## Did you miss...

**"The Really Shocking Royal Secret: British Crown Rules the Greens" in *21st Century*, Winter 1994-1995?**

Back issues are available at \$5 each.

# BEN FRANKLIN

Booksellers & Record Shop



- Riemannian Geometry—A Beginner's Guide**, by Frank Morgan. Physically oriented; lacks philosophy. Jones and Bartlett hardcover, \$29.95
- Measuring the Universe—Cosmic Dimensions from Aristarchus to Halley**, by Albert van Helden. U. of Chicago, \$12.95
- The Librarian Who Measured the Earth**, by Kathryn Lasky. A book about Eratosthenes for elementary school children. Little, Brown hardcover, \$16.95
- Tirion's Bright Star Atlas 2000**. Willmann-Bell, \$9.95
- Cloak of Green**, by Elaine Dewar. Links between the Greens, government, and big business. Lorimer, \$22.95
- Batling Wall Street—The Kennedy Presidency**, by Donald Gibson. A book every anti-Green should read. Environmentalism in context. Sheridan Sq. hardcover, \$24.95

## Ben Franklin Booksellers

107 South King Street  
 Leesburg, Virginia 22075  
 Phone (703) 777-3661  
 Toll free (800) 453-4108  
 Fax (703) 777-8287

Type of credit card (circle one):  
 MasterCard    Visa    Discover    AmEx

Credit card # \_\_\_\_\_

Exp. date \_\_\_\_\_

Name \_\_\_\_\_

For shipping, add \$3.50 for first book  
 and \$.50 for each additional book.  
 For Canada add \$7 and \$1.30.

Address \_\_\_\_\_

City \_\_\_\_\_

Total book price \$ \_\_\_\_\_

State \_\_\_\_\_ Zip \_\_\_\_\_

Plus shipping \$ \_\_\_\_\_

Home phone \_\_\_\_\_

Va. residents add

Business phone \_\_\_\_\_

4.5% sales tax \$ \_\_\_\_\_

Total enclosed \$ \_\_\_\_\_

buy political influence. [WWF] has hired people who have worked for intelligence agencies. The objectives of the organization can be interpreted as real concern for the dangers facing human life or as attempts by managers and owners of multinational corporations with considerable influence on Western governments, to preserve areas likely to produce the riches of the future."

## QED Coherence in Matter

by Giuliano Preparata, *University of Milan*

Condensed matter is not an electrostatic erect set! A new paradigm is emerging, which builds condensed matter through the long range quantum-electrodynamic interaction. This interaction creates coherent configurations of atoms and molecules, which oscillate in phase with a coherent macroscopic (and classical) electromagnetic field that, through the strong interaction with matter, remains trapped inside it.

Paperback, 252 pages, \$67.00

**World Scientific**

1060 Main Street • River Edge, N.J. 07661  
 1-800-227-7562

## Media Myths

How has this apparatus been able to control the environmental debate? Dewar describes the role of the news media in creating the myths used by the environmental movement. For example, Dewar notes the critical role in the rainforest campaign played by David Suzuki, the superstar of the Canadian Broadcasting Company, and Barbara Pyle, environment editor of CNN (Cable News Network) and head of the documentary unit for Turner Broadcasting System (TBS) in Atlanta.

Marveling at "the cohesion in a group of such peculiar composition. . ." as that present at the reception noted above, Dewar points out that CNN's "Barbara Pyle had already made a film on Paiakan for TBS. She had attended Altamira. Now she was poised to run more fundraisers for Paiakan in the U.S. This seemed to me an obvious conflict of interest for a media person. I'd never heard of a television network that allowed those who chose its news and documentary topics also to raise money

for people they'd covered. . . ."

Not only Pyle, but Ted Turner, her boss, played a key role in promoting all these operations, as Dewar outlines in detail. This was done both through the creation of the Better World Society, whose goal is to implement the Global 2000 report, as well as through the filming and airing of dozens of biased, inaccurate documentaries in the Turner Broadcasting Network.

For those who are fighting for scientific and technological progress, this book is good background. And if you've been snookered into supporting the groups that raise money to prevent environmental doomsdays, this book just might help save your money for real causes.

**Notes**  
 \* Offprints of this 64-page report are available from EIR News Service, at \$10 each, P.O. Box 17390, Washington, D.C. 20041-0390.



To order these books, (24hrs, 365 days)  
 please call (800) 96-Book-1 (Ext. 3800)





Plant seeds of  
knowledge.

***The Holes in the Ozone Scare:  
The Scientific Evidence That the  
Sky Isn't Falling***

by Rogelio A. Maduro and  
Ralf Schauerhammer  
\$15 each, plus \$3 shipping  
OR \$10 postpaid with a subscription

***Video on the ozone hoax  
"Fair Skin—Stay In"***

1-hour documentary produced by  
the Belgian television network  
BRTN. VHS, English narration,  
some subtitles.  
\$20 each, plus \$3 shipping

***How We Got to the Moon:  
The Story of the German Space  
Pioneers***

by Marsha Freeman  
\$15 each, plus \$3 shipping  
OR \$10 postpaid with a subscription

***Hermann Oberth:  
The Father of Space Flight***

by Boris V. Rauschenbach  
\$15 each, plus \$3 shipping  
Or \$12 postpaid with a subscription

***Global Warming:  
The Rest of the Story***

by Dr. Gerd Weber  
\$11 each, postpaid  
OR \$8 postpaid with a subscription

**Order form**

- Enclosed is \$ \_\_\_\_\_ total for
- \_\_\_\_\_ \$25 for a 6-issue subscription (U.S.)
  - \_\_\_\_\_ \$50 for a 6-issue subscription (foreign airmail)
  - \_\_\_\_\_ \$10 for *The Holes in the Ozone Scare* with a subscription
  - \_\_\_\_\_ \$18 for *The Holes in the Ozone Scare* postpaid
  - \_\_\_\_\_ \$10 for *How We Got to the Moon* with a subscription
  - \_\_\_\_\_ \$18 for *How We Got to the Moon* postpaid
  - \_\_\_\_\_ \$12 for *Hermann Oberth* with a subscription
  - \_\_\_\_\_ \$18 for *Hermann Oberth* postpaid
  - \_\_\_\_\_ \$8 for *Global Warming* with a subscription
  - \_\_\_\_\_ \$11 for *Global Warming* postpaid
  - \_\_\_\_\_ \$23 for "Fair Skin—Stay In" video, postpaid

Please print or type name and address of gift recipients on  
a separate paper. Gift cards are available.

Call or write for prices on bulk copies of books.

Name \_\_\_\_\_

Address \_\_\_\_\_

City \_\_\_\_\_ State \_\_\_\_\_ Zip \_\_\_\_\_

Daytime telephone (\_\_\_\_) \_\_\_\_\_

Send check or money order (U.S. currency only) to:  
21st Century, P.O. Box 16285, Washington, D.C. 20041



## In This Issue:

### RIEMANN REFUTES EULER

Riemann's posthumously published "Philosophical Fragments," presented here for the first time in English translation, destroy the fiction created by Euler and other Newtonians that mathematical discontinuities do not exist. As Lyndon H. LaRouche, Jr., shows in his introduction to the translation, Riemann's broader point is that scientific truth depends on metaphor, and cannot be determined by mathematical proofs on a blackboard, or by computers.

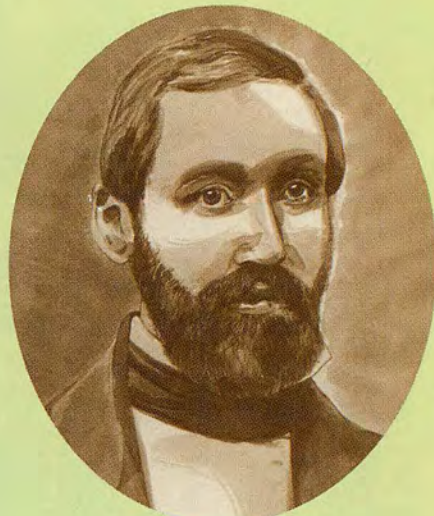
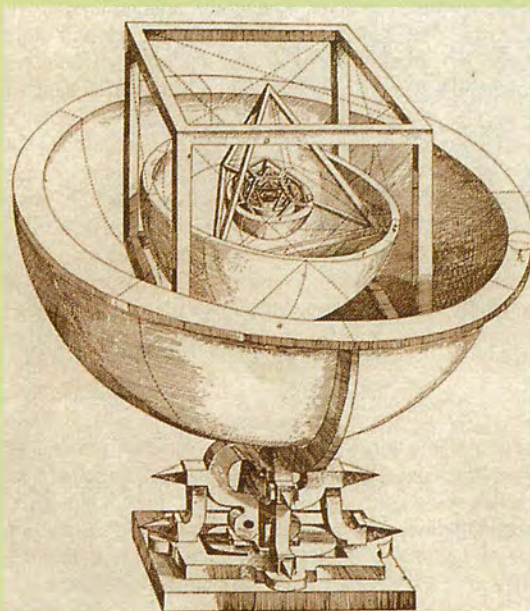

Illustration by Pam Emerson

Bernhard Riemann (1826-1866)



### 400th ANNIVERSARY: KEPLER, NOT NEWTON GAVE BIRTH TO MODERN PHYSICS

Four hundred years ago, Johannes Kepler discovered the harmonic ordering of the solar system and transformed astronomy, cosmology, and physics into an entirely new science. His physics and his method go far beyond anything that Isaac Newton and his followers are capable of knowing or explaining. In celebration of the 400th anniversary of Kepler's first work, *Mysterium Cosmographicum* (Mystery of the Universe), Ralf Schauerhammer annotates excerpts from the book.

*Kepler derived the planetary orbits by an ordered nesting of the five Platonic solids, the orbits being the spheres circumscribing and inscribing them.*

### IN THE FOOTSTEPS OF KEPLER

As part of the Kepler celebration, this issue features the work of Father Magnus J. Wenninger, the first geometer to construct models of the 75 uniform polyhedra and their duals, according to Kepler's specifications. Charles Stevens discusses Wenninger's models and the method by which the master polyhedra builder explores new constructions.

*A selection of Wenninger's models: From left, Kepler's stella octangula, small stellated dodecahedron, ninth stellation of the icosahedron, icosahedron, and small rhombicuboctahedron. More detailed descriptions appear on p. 68.*

