

21st CENTURY SCIENCE & TECHNOLOGY

FALL 2004

www.21stcenturysciencetech.com

\$3.50/IN CANADA \$4.50

INSIDE
THE NUCLEUS

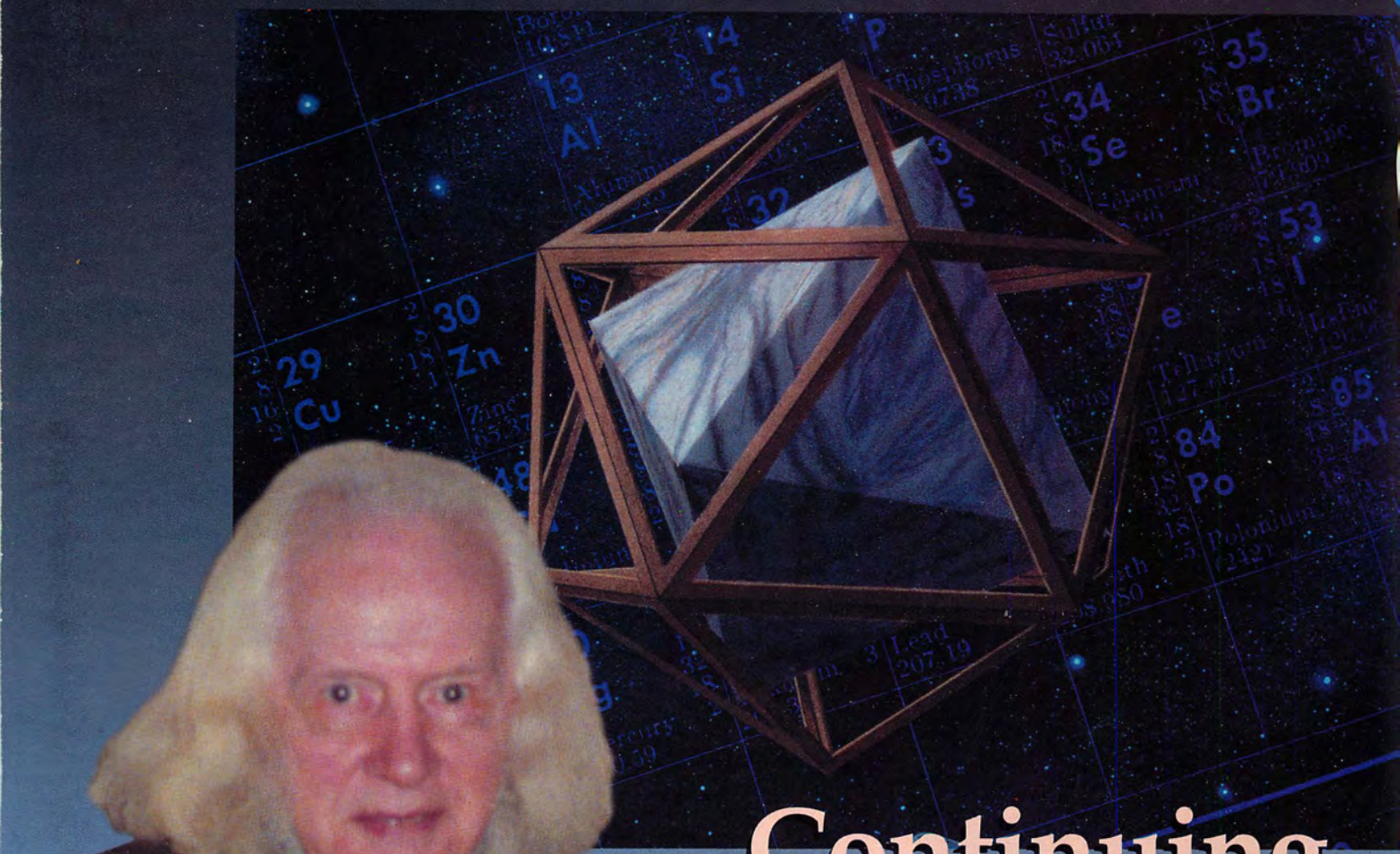

Continuing The Legacy of Dr. Robert J. Moon



Expand your world view with

21st CENTURY SCIENCE & TECHNOLOGY

TRACE Project/NASA

An ultraviolet light view of sunspot loops. The glowing gas flowing around the sunspots has a temperature of more than 1 million degrees C.

Subscriptions

U.S.—6 issues for \$25

Foreign—6 issues for \$50

Books

*The Holes in the Ozone Scare:
The Scientific Evidence
That the Sky Isn't Falling*

by Rogelio A. Maduro and
Ralf Schauerhammer

\$15 each, plus \$3 shipping

OR \$10 postpaid with a subscription

*How We Got to the Moon:
The Story of the German Space
Pioneers*

by Marsha Freeman

\$15 each, plus \$3 shipping

OR \$10 postpaid with a subscription

*Global Warming:
The Rest of the Story*

by Dr. Gerd Weber

\$11 each, postpaid

OR \$8 postpaid with a subscription

Hermann Oberth:

The Father of Space Flight

by Boris V. Rauschenbach

\$15 each, plus \$3 shipping

OR \$12 postpaid with a subscription

Give 21st Century subscriptions and gifts

ORDER FORM

Enclosed is \$ _____ for:

_____ 6 issues/ U.S.— \$25

_____ 6 issues/ foreign airmail—\$50

_____ 12 issues/ U.S.—\$48

_____ 12 issues/ foreign—\$98

_____ \$10 for *The Holes in the Ozone Scare* with a subscription

_____ \$18 postpaid for *The Holes in the Ozone Scare*

_____ \$10 for *How We Got to the Moon* with a subscription

_____ \$18 postpaid for *How We Got to the Moon*

_____ \$8 for *Global Warming* with a subscription

_____ \$11 postpaid for *Global Warming*

_____ \$12 for *Hermann Oberth* with a subscription

_____ \$18 postpaid for *Hermann Oberth*

Please print or type name and address of gift recipients on a separate paper. Gift cards are available.

Note: Back issues are available at \$5 each (\$8 foreign)

Name _____

Address _____

City _____ State _____ Zip _____

Daytime telephone (_____) _____ e-mail _____

Send check or money order (U.S. currency only) to:

21st Century, P.O. Box 16285, Washington, D.C. 20041.

www.21stcenturysciencetech.com

21st CENTURY SCIENCE & TECHNOLOGY

Vol. 17, No. 3

Fall 2004

Features

- 8 The Life and Work of Dr. Robert J. Moon
- 8 1. Robert J. Moon on How He Conceived His Nuclear Model
What Was the von Klitzing Experiment? Ralf Schauerhammer
Low-Energy Positrons in Pair Creation Erich H. Bagge
Prof. Bagge's 'Geometric Nucleus' Ralf Schauerhammer
- 26 2. Dr. Robert J. Moon: 'Space Must Be Quantized'
- 28 3. Pauling and Others Comment on the Moon Model
- 30 4. The Gifts of Louis de Broglie to Science
Robert J. Moon
- 36 5. On the Filamentary Electron, Neutrinos, and Nuclear History (1984 Interview)
- 40 6. Cold Fusion Is No Surprise (1989 Interview)
Every Electron Communicates with Every Other
- 45 7. Dr. Moon and the Chicago Cyclotron
- 46 8. Moon's Proposal for a Fundamental Experiment in Electrodynamics
- 47 9. Dr. Moon in the News
- 56 10. A Reminiscence from the Manhattan Project
James A. Schoke
- 57 11. Some Writings of Robert J. Moon and William Draper Harkins
Dr. Moon's Curriculum Vitae (1941)
- 58 REPORT ON WORK IN PROGRESS
New Explorations with the Moon Model
Laurence Hecht with Charles B. Stevens
Toward a new model of the nucleus, based on the pioneering work in physics of Dr. Robert J. Moon.
- 74 SCIENCE & THE LAROCHE YOUTH MOVEMENT
Dr. Moon and the Simultaneity of Eternity
Amie Acheson

News

- NUCLEAR REPORT
79 U.S. and Russian Labs Call for Nuclear Renaissance
Marsha Freeman

Departments

- EDITORIAL
2 Robert J. Moon: Scientist for the 21st Century
Laurence Hecht
- 4 NEWS BRIEFS
- IN MEMORIAM
6 DDT Champion
Gordon Edwards (1919-2004)
- 7 LETTERS
- BOOKS
77 RICHARD NELSON THOMAS—
NONEQUILIBRIUM
THERMODYNAMICAL ASTROPHYSICIST
Nora Andreasian, Editor
Reviewed by David Cherry



Gordon Edwards, who died July 19 at age 85, here eats a spoonful of DDT, a feat he repeated regularly in his campaign to demonstrate that DDT was not harmful to human beings. This photograph appeared in *Esquire* magazine, September 1971.

On the Cover: Robert J. Moon in 1987. Photo by Tom Szymeko; geometric model illustration by Christopher Sloan. Cover design by Alan Yue.

Robert J. Moon: Scientist for the 21st Century

EDITORIAL STAFF

Editor-in-Chief

Laurence Hecht

Managing Editor

Marjorie Mazel Hecht

Associate Editors

Elijah C. Boyd

David Cherry

Marsha Freeman

Colin M. Lowry

Gregory B. Murphy

Elisabeth Pascali

Richard Sanders

Charles B. Stevens

Books

David Cherry

Art Director

Alan Yue

Advertising Manager

Marsha Freeman

SCIENTIFIC ADVISORY BOARD

Francesco Celani, Ph.D.

Hugh W. Ellsaesser, Ph.D.

James Frazer, Ph.D.

John Grauerholz, M.D.

Emmanuel Grenier

Lyndon H. LaRouche, Jr.

Wolfgang Lillge, M.D.

Ramtanu Maitra

Thomas E. Phipps, Jr., Ph.D.

B.A. Soldano, Ph.D.

Jonathan Tennenbaum, Ph.D.

21st Century Science & Technology (ISSN 0895-6820) is published 4 times a year by 21st Century Science Associates, 60 Sycolin Road, Suite 203, Leesburg, Va. 20175. Tel. (703) 777-6943.

Address all correspondence to **21st Century**, P.O. Box 16285, Washington, D.C. 20041.

21st Century is dedicated to the promotion of unending scientific progress, all directed to serve the proper common aims of mankind.

Opinions expressed in articles are not necessarily those of 21st Century Science Associates or the scientific advisory board.

We are not responsible for unsolicited manuscripts.

Subscriptions by mail are \$25 for 6 issues or \$48 for 12 issues in the USA and Canada. Airmail subscriptions to other countries are \$50 for 6 issues. Back issues are \$5 each (\$8 foreign). Payments must be in U.S. currency.

Copyright © 2004

21st Century Science Associates

Printed in the USA ISSN 0895-682

www.21stcenturysciencetech.com

We are currently engaged in a careful study of a founding document in the science of hydrodynamics authored by the famous Weber brothers, the *Wellenlehre auf Experimente gegründet*¹ (Wave Theory Based on Experiment). The content and method of this 1825 work relate to the central topic of this Fall issue in several important and interconnected ways, such that a brief discussion of the matter may help establish in the mind of the reader a better appreciation of the significance of the life and work of our dear friend Robert J. Moon (1911-1989).

It was Moon's emphasis on the work of Louis de Broglie, which, by an indirect route that those familiar with the subject could easily guess, first led us to examine the Weber brothers' work. What first fascinated us was the repeated appearance of phrases such as "Unsere Versuche mit Stimmgabeln scheinen diesem Satze Poisson's zu widersprechen" (Our experiments with tuning forks seem to contradict this proposition of Poisson). In the detailed Table of Contents, and even more delightfully so in the text, the phrase "the assumption of [—] does not correspond with the results of our experiments" appears again and again—such illustrious names as Newton, Euler, d'Alembert, Lagrange, Laplace, Savart, Biot, Cauchy, and Poisson appearing to have been in serious error in the assumptions on which they based crucial aspects of their mathematical theory of waves.

Blackboard Mathematics

As we read deeper, it became obvious that the the work, apart from being a crucial foundation for wave theory, was also intended to serve as a refutation of the dominance of ivory tower or blackboard mathematical methods, still prevalent today in the teaching of the sciences, mathematical physics in par-

ticular. The point of the work was precisely the same as that posed by the young Carl Friedrich Gauss in his famous 1799 paper on the Fundamental Theorem of Algebra: Is it possible to arrive at a truth concerning man's relationship to the physical universe by means of *a priori* mathematical formalisms of the sort implied in Euclid's *Elements*, or in the treatment of the so-called imaginary number?

In his youthful 1799 paper, as in all subsequent locations, Gauss came down in no uncertain terms against such a proposition, exposing in particular the false assumptions of Euler, d'Alembert, and Lagrange. It was thus no surprise that the younger of the Weber brothers, Wilhelm (who was 21 at the time of publication of the work on wave theory), was to become the principal assistant to Carl Friedrich Gauss in his groundbreaking researches on electrodynamics and Earth magnetism. For Gauss, no mathematical truth were possible without a grounding in experiment, a point his most famous student Bernhard Riemann was to elaborate and make explicit in his famous, and still under-appreciated 1854 Habilitation Thesis.²

War Against Gauss

For science, the tragedy of the 19th Century, a tragedy whose consequences still haunt us, was that that beautiful classical tradition embodied by Gauss, his younger collaborator Wilhelm Weber, and Bernhard Riemann, was nastily suppressed by an operation run from England by such figures as William Thomson Lord Kelvin, Tait, Maxwell, and Rayleigh, and supported in Germany by figures including Grassmann, Clausius, and Helmholtz.

Whoever knew Bob Moon was witness to the fact that, despite all efforts to suppress, deny, and coopt, that tradi-

tion had never died. To be around Moon, as one of his younger collaborators noted, was like being around a modern-day Benjamin Franklin. In Moon one saw embodied the greatest tradition of American science, the continuing legacy of Benjamin Franklin as it had been passed on through the great-grandson Alexander Dallas Bache, his ally Joseph Henry and the other early leaders of the American Association for the Advancement of Science. Through his teacher William Draper Harkins—a protégé of the seminal figure in German chemistry, Fritz Haber, when studying abroad in his pre-World War I youth—and through Moon's own close ongoing friendship with Göttingen's James Franck, came the direct line of

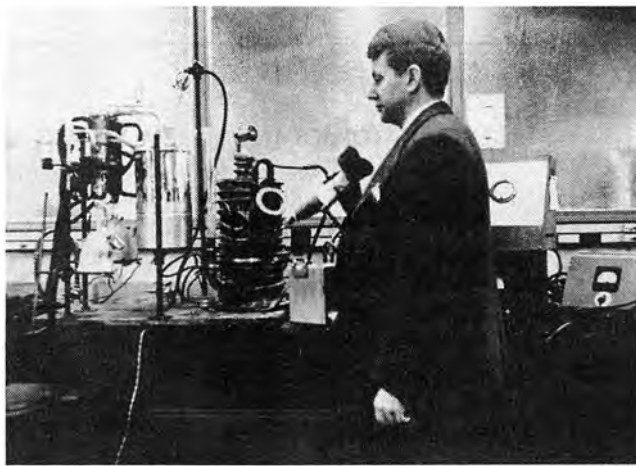

Robert J. Moon, about 1948, with the vacuum furnace he used in constructing the world's first scanning X-ray device.

connection to continental science.

Together these interwoven traditions—the American and the continental, from such collaborators of Gottfried Leibniz in the Pennsylvania colony as

Franklin's mentor Governor James Logan, to the revivers of the nearly suppressed Leibniz such as Abraham Kästner and his circles at Göttingen—found their disciple in this modest, self-effacing, yet infectiously passionate devotee of the truth. Let his legacy continue.

—Laurence Hecht

Notes

1. Ernst Heinrich and Wilhelm Eduard Weber, *Wellenlehre auf Experimente gegründet* (Leipzig, 1825) and Vol. 5 of *Wilhelm Weber Werke* (Berlin, 1893).
2. "The question of the validity of the postulates of geometry in the indefinitely small is involved in the question concerning the ultimate basis of relations of size in space. . . . A decision upon these question can be found only by starting from the structure of phenomena that has been approved in experience hitherto. . . ." "On the Hypotheses which Lie at the Foundations of Geometry," *A Source Book in Mathematics* (New York: Dover, 1959) pp. 424-25.

LaRouche on Honoring Moon's Scientific Work

Remarks of Lyndon H. LaRouche, Jr. to a meeting of his associates, Oct. 4, 1997.

[B]eginning about 1986, at the time we had these sessions at Ibykus [Farm], it suddenly clicked in Bob Moon's mind, with help of the discussions he had with Larry Hecht at the time, that my scientific work was extremely important. Now, Moon had been interested in scientific discussions with me in 1975, about 10 years earlier. But, under the influence of some of my associates, for example, had been discouraged from following my scientific work—namely, Steve Bardwell, and that crowd and so forth had discouraged him. And suddenly, he realized, when I was using these Riemannian spherical projections, he realized, when I was describing this for economics, that I was right. . . .

Now, Moon had first presented this Ampère concept to me, back in '75. It happened shortly following the meeting we had at the Tudor Hotel complex, the first meeting which founded the (later) Fusion Energy Foundation.

And, Moon came over to discuss a problem which I had raised, and which he was concerned about, which we discussed heavily, in the context of that Tudor meeting. That was the fact that the argument on fusion, fusion energy, was the problem of the so-called Coulomb force—that is, that there are forces of repulsion of like charges, which these foolish people, with their linearization in the small, had extended into a region, within (that is, smaller than) the first electron orbit. Which is absurd. And, we said, this is pure speculation, based on linearization in the small. There's no reason to assume this.

The Ampère Force

So, Moon's response was, when he came to visit me, over in Washington Heights, was to say, "Look. Look at the Ampère principle. Look what Maxwell did." And he laid out, very quickly, the longitudinal force case, which we might call, alternately, the angular force—another way of looking at it; laid it out, and repeated that to a number of people who came to a meeting at that time. So, back in the mid-1980s, he and Larry

went to work in this direction, and Larry recalled that, at the summer camp, that what Moon emphasized to the children was this Ampère experiment, the solenoid experiment, which is a key to breaking into this area; a way of looking at physics from the standpoint of Ampère, rather than alternatives.

So, it seemed to me, in light of all these related things. . . . I said, "Wait a minute." What we're dealing with, Larry's impulses—and my own converging impulses on this question of the whole catenoid functions, or the hypergeometric functions, which I've been obsessed with for some time, and for a while, Chuck Stevens was heavily involved in that. This is all the work of Bob Moon, in the sense that, not that it was all original to him; but Bob Moon was the person among us, deceased in '89, a highly distinguished figure of American 20th Century science, who we must honor. Because, by honoring him, we are honoring, morally an indebtedness to ideas, and to the people who play a leading role in fostering their development.

GENERAL ATOMICS AND LIVERMORE WIN AWARD FOR MAGLEV WORK

The Inductrack Magnetic Levitation System, invented at Lawrence Livermore National Laboratory and under development by General Atomics in San Diego, won an award in September from *R&D* magazine as one of the top 100 technologically significant new products. A 400-foot long test track is nearing completion at General Atomics, with a full-sized vehicle chassis and associated power and control systems.

The Inductrack uses un-powered arrays of permanent magnets beneath the vehicle. When the train is in motion, the magnetic field from the permanent magnets generates levitation by interaction with a track made up of conductors. The maglev system is being developed as part of the Urban Magnetic Levitation Transit Technology Development Program.

U.S. AID QUIBBLES ABOUT DDT, WHILE MILLIONS DIE OF MALARIA

Anne Peterson, the physician who is assistant administrator of the Bureau for Global Health of the U.S. Agency for International Development, testified before the House International Relations Committee, Sept. 14, that "Contrary to popular belief, U.S. AID does not ban the use of DDT in its malaria control programs." But the rest of her remarks made it clear why "popular belief" is that DDT is banned by the U.S. agency.

The USAID, she said, has judged it "more cost-effective and appropriate to put U.S. government funds into other malaria control activities." The prevention activity of choice is "Insecticide Treated Nets," which she notes are used by only 2 percent of African children. Is it any wonder that malaria incidence has increased during the USAID "partnered" Roll-Back Malaria campaign? Malaria is the third largest killer disease, but it is more common than AIDS and TB; 500 million persons annually are afflicted with acute malaria, and one child dies of malaria every 30 seconds in Africa.

NIGERIA LAUNCHES ITS FIRST NUCLEAR RESEARCH REACTOR

Nigeria launched its first nuclear reactor for scientific research Sept. 30, at Ahmadu Bello University in Zaria, northern Nigeria. The reactor was built by the Center for Energy Research and Training at the University, with technical assistance from the International Atomic Energy Agency. The research reactor will be used for measuring elements in the soil, mineral identification, petroleum exploration, and isotope production for medical use.

DR. STEPHEN DEAN RECEIVES 'SENIOR FUSION STATESMAN' AWARD

Dr. Stephen Dean, the president of Fusion Power Associates, received the "Senior Statesman of the Fusion Program Award," at a meeting on the Technology of Fusion Energy, sponsored by the American Nuclear Society Sept. 14-16. The award recognized Dean's many years of contributions to nuclear fusion power, citing, in particular, Dean's "stimulating the development of young scientists; maintaining a focus on the end product of fusion; keeping industry and utilities involved; and providing a platform for policy discussions." In the 1970s, Dean was senior manager of the U.S. magnetic fusion program. In 1979, he founded Fusion Power Associates as a way of bringing electric utilities and industry into an expanded fusion effort—which, at that time, was on the road to developing an engineering test reactor and then a full-scale demonstration reactor, to open the age of unlimited energy.

Dean reviewed the history of the U.S. fusion program at the meeting, noting that in 1976, the predecessor agency to today's Department of Energy published "a detailed fusion program plan, suggesting that, if a sequence of advanced test facilities were constructed in a timely fashion, fusion electricity could be on the [electric] grid in a Demonstration Power Plant by the year 2000. . . . This plan was codified by Congress in the Magnetic Fusion Energy Engineering Act of 1980, signed by President Carter on Oct. 7, 1980." But, the Act was never funded at the level necessary to meet its goals.



General Atomics

The Maglev test vehicle, now in final preparation at General Atomics in San Diego, with Bob Baldi (left) and Sam Gurol, program manager.

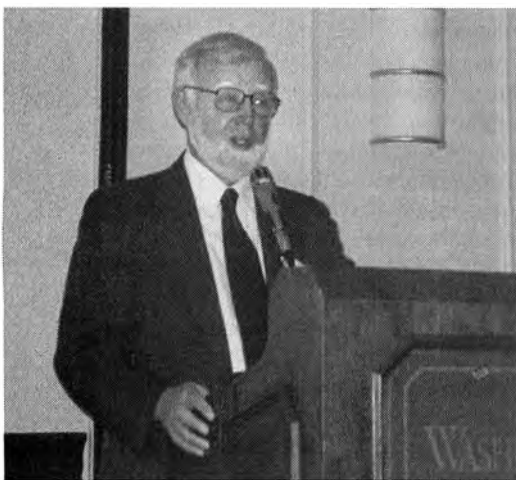

Marsha Freeman

Fusion energy "Senior Statesman" Dr. Stephen Dean, president of Fusion Power Associates, speaking here at a 1999 meeting in Washington, D.C.

DOE AWARDS FABRICATION CONTRACTS FOR PRINCETON STELLARATOR

The Department of Energy awarded two subcontracts for the fabrication of the vacuum chamber and the winding forms for the fusion power research project known as the National Compact Stellarator Experiment (NCSX), which is under construction at the Princeton Plasma Physics Laboratory. The \$86.3 million project is scheduled to begin operation in 2008. A team led by Energy Industries of Ohio, Inc. will manufacture the winding forms upon which the stellarator's modular electromagnetic coils will be mounted. The forms have to support electromagnetic loads in the range of 7,000 pounds per inch. Major Tool and Machine, Inc. of Indianapolis will build the 25,000-pound vacuum chamber. It will be made of Inconel 625, an alloy that has high electrical resistivity. The NCSX is a smaller size than traditional stellarators, and will combine the best features of a stellarator and a tokamak.

The NCSX is a joint project of the Princeton lab and the Oak Ridge National Laboratory. An Oak Ridge team designed the magnetic field coil system, which shapes the plasma, and the vacuum vessel, which contains it.

CHINA DEMONSTRATES ITS HIGH-TEMPERATURE REACTOR SEPT. 30

China hosted 60 atomic energy experts from 30 countries at a demonstration of the safety of its new high-temperature gas-cooled reactor, which was designed by Tsinghua University in Beijing. The nuclear experts watched as the reactor cooled down on its own after its control rods were withdrawn. The HTGR was connected to the power grid in 2003, and a larger 160-MW HTGR is expected to come on line in 2010.

GERMANY FACES AN ERA OF BLACK-OUTS, WITHOUT NEW NUCLEAR PLANTS

Unless there are massive investments in power production and power grids, and a return to nuclear technologies, Germany will face an era of black-outs. This was the main conclusion of a press conference by the federal association of the German electrical engineering sector, ZVEI, in Mannheim in September. ZVEI board member Joachim Schneider noted, that since the liberalization of the German energy sector in 1998, investments into power plants have crashed by 45 percent and investments into power grids by 30 percent. The mounting investment backlog is all the more dangerous because rising numbers of intrinsically unreliable windmills require ever more traditional power capacities to be held in reserve. The liberalization has also led to a sharp rise in the power trade, which put an additional burden on power grids. Much of the grid infrastructure is now more than 50 years old and has to be replaced soon.

NEW STUDY SAYS 'IT'S SAFE TO EAT FISH'

The Center for Science & Public Policy (www.scienceandpolicy.org) released a study Sept. 28, which concludes that there is no scientific evidence to support claims that eating ocean fish will expose pregnant women and infants to health risks, and that there is a greater health risk in avoiding fish than in consuming it. The Environmental Protection Agency's recommended consumption level is largely based on a flawed study of Faroe Islands children, the report says, and it is likely that deep ocean vents are the dominant source of the trace methyl-mercury that has historically bio-accumulated in ocean fish, not mercury emissions from coal-fired plants.

100 NUCLEAR POWER STATIONS—OR 100,000 WINDMILLS FOR HYDROGEN?

A report on the Arithmetic of Renewable Energy, by researchers at Warwick University in England, calculated that if Britain were to switch from petroleum to hydrogen fuel for motor vehicles, it would have to build 100 nuclear power plants or 100,000 wind turbines to produce the hydrogen. As reported in the London *Guardian*, Oct. 7, the researchers themselves were startled by their study results. "The enormity of the green challenge is not understood," said energy consultant Jim Oswald. The 100,000 windmills would cover a land mass the size of Wales, if onshore, or would form a six-mile-deep strip circling the coast of the British Isles, the Warwick study said.



Courtesy of Oak Ridge National Laboratory

The prototype form around which the magnetic field coils will be wound. The twisted donut shape was designed to help prevent plasma disruption, sustain longer fusion reactions, and confine the plasma so that it does not lose energy.



DDT Champion Gordon Edwards (1919-2004)

Entomologist J. Gordon Edwards, a champion of DDT, died July 19, 2004, of a heart attack while mountain climbing in Glacier National Park in Montana. Dr. Edwards, who was a few days short of his 85th birthday, was a professor emeritus at San Jose State University in California and still active in the fight to tell the truth about DDT and other environmental issues. Edwards became famous for eating a big spoonful of DDT at the start of each semester's entomology classes, just to prove that the pesticide was not harmful to humans.

Edwards was a traditional naturalist and birdwatcher, who had looked forward to reading Rachel Carson's *Silent Spring* in 1962, but noticed some things in her book that didn't seem quite right to him. As he described it: "As I neared the middle of the book, the feeling grew in my mind that Rachel Carson was really playing loose with the facts and was also deliberately wording many sentences in such a way as to make them imply certain things without actually saying them. She was carefully omitting everything that failed to support her thesis that pesticides were *bad*, that industry was *bad*, and that any scientists who did not support her views were *bad*." Edwards then began to check Carson's references, and found that she lied about the results of the research studies she reported!

To give one example, Carson reported on a study that found that pheasants fed DDT hatched fewer eggs than a control group, and their chicks didn't survive. Actually, the DDT pheasants hatched 80.6 percent of their eggs, while the controls hatched only 57.4 percent of their eggs. After eight weeks, the DDT-fed pheasant chicks had a 93.3 percent survival rate, while the control chicks had only an 89.7 percent survival.

Fighting for Truth in Science

Edwards's experience documenting the lies of "Silent Spring" turned into a commitment to give the public the truth about pesticides and the environment. He was prompted to turn his



Stuart Lewis/EIRNS

notes on "Silent Spring" into an article, when he learned in 1992 that a movie honoring Carson was being produced for TV. Edwards did not want Carson's lies, which he stated were responsible for the deaths of millions of people, to go unchallenged.

Several of his articles have appeared in *21st Century* and LaRouche publications over the years. His article, "The Lies of Rachel Carson," appeared in the summer 1992 issue of *21st Century* and is on the magazine website.

Edwards continued to battle tirelessly for the truth about DDT, and testified against the efforts to ban it in state and national hearings. When William Ruckelshaus, administrator of the Environmental Protection Agency in 1972, decided to ban DDT despite the official decision of an EPA Hearing Examiner *not* to ban it, after seven months of hearings, Edwards continued to expose the unscientific, political motivation for the ban. He estimated a decade later, in an interview with this author, that the U.S. ban on DDT was directly and indirectly responsible for the deaths of 100 million persons a year—most of them in Africa.

When Edwards and other scientists (Tom Jukes, Bob White-Stevens, Donald Spencer, and Nobel Prize recipient Normal Borlaug) were libelled by *The New York Times* on Aug. 14, 1972 as "paid scientist spokesmen," they sued for libel and won in a jury trial.

The *Times* was furious at its loss, and appealed the case, which went before a Circuit Court appeals panel

headed by Judge Irving Kaufman, a close friend of the *Times* publisher. Kaufman, the same judge who had sent the Rosenbergs to the electric chair, ruled in favor of the *Times*. Kaufman's decision stated:

"To call the appellees, all of whom were university professors, *paid* liars clearly involves defamation that far exceeds the bounds of the prior controversy. No allegation could be better calculated to ruin an academic reputation. And to say a scientist is *paid* to lie implies corruption. . . . Such a statement requires a factual basis, and no one contends there was any serious basis for such a statement in this case. . . .

"[I]t is unfortunate that the exercise of liberties so precious as freedom of speech and of the press may sometimes do harm that the state is powerless to recompense: but this is the price that must be paid for the blessing of a democratic way of life."

A World-Renowned Entomologist

Edwards trained generations of entomologists in telling the truth, and many of them gathered to honor him at his 70th birthday. But as science became more and more green, the Biology and Entomology Departments at San Jose State tried to edge Edwards out. He prevailed, however—although in a smaller office space. The University dedicated its entomology museum as the J. Gordon Edwards Museum of Entomology in his honor in 1990. It houses more than a million insect specimens, including Edwards's private collection from around the world. But Edwards was forced to take home his voluminous files on DDT, pesticides, and environmentalists.

Edwards was known worldwide as an entomologist—and revered as a mountaineer. His book *A Climber's Guide to Glacier National Park*, was published in 1961 and reprinted and updated many times. Edwards spent nine years as a park ranger/naturalist in Glacier, starting in 1947, and he returned there almost every summer to hike with his family. He was known at

Continued on page 7



Letters

A Confederate Questions The American System

To the Editor:

Mr. Irwin's premise in his article ["From Lincoln to LaRouche's Eurasian Land-Bridge: On the Implementation of Technology," Summer 2004, p. 14] is overall sound. That is, governments are there to lead the people in economics by initiating policies that will enhance economic growth. How? Mainly by getting the hell out of the way of private enterprise and protecting personal property.

However, there are some historical points in his paper that are taken directly from the dumbed-down school books of the public indoctrination centers. This I find distasteful. *21st Century* supports the rejection of the Status Quo in science; well, now its time to do the same with history.

Mr. Irwin states: "Because of Lincoln, both Northerners and Southerners had productive jobs to come home to after the civil war. . . ." What? . . . Oh, by the way, 90% of the Civil War took place IN the South. That is why the war in the South is called . . . "The War of the Northern Aggression." Leaving nothing but ruins for those that did survive. Did the Northern industry suffer any war damage? No! Those southern survivors then where sucked dry of anything they still had of value by the "Carpet Baggers," who operated with the full blessing of Lincoln Administration. . . .

Mr. Irwin states, "Lincoln inherited the Civil War." This is pure Bovine Scatology. Lincoln created it. This is common knowledge amongst those that do not support the Northern revisionist history. . . .

Mr. Irwin stated, Lincoln wanted to implement industry in the South. He did this by dispossessing the Southerners of all of their property, not just the Negroes. . . .

As written in the revisionist history, Lincoln was a "nobody that after a short term in Congress just walked into the White House" (Where he set up his own form of tyranny). Well, believe that if you wish. I find it hard to swallow. He had to have political power supporting

this to pull it off. . . .

What really bothers me about the whole transnational railway is that it is obsolete even before it gets the first rail road spike. Why are we still stuck using technology that glues us to the ground? Cars and trains, regardless of what powers them or how fast they go, is 1800s technology. When will we grow up? When will we stop paving tillable earth to make roads and railways? . . . When will we use some form of anti-gravity vehicles?

**Wes Gordon
Tulsa, Okla.**

The Author Replies

Mr. Gordon: I want you to know first, and foremost, you have my personal assurance that the Larouche Youth Movement will not allow any slaves on Mars once we colonize it.

Space travel may be a little emotionally uncomfortable at first for those accustomed to the "Southern agrarian lifestyle," but I assure you again, an ongoing process of technological development guided by a mission orientation for discoveries, is much more fun than sitting on one's porch, sippin' a cool glass of lemonade, watching someone else "till the soil." Human beings, with creative minds, who happen to have a darker skin color than your own, would appreciate a policy for building 500-mph "anti-gravity" mag-lev trains, new water irrigation projects, and beautiful new cities, even after being offered the anti-American alternative of pickin' cotton in Oklahoma in 100-degree heat.

A Southern economy based on exploitation of human "property" was doomed to collapse, just as the Anglo-American Imperial, Free Trade system of "World Government" is collapsing in front of your eyes, as well as mine, today. Only a policy of physical transformation of the biosphere, in which we live, with continuous advancements in technologies, will sustain higher qualities of human life for generations to come.

Such was the concept of Leibniz, proclaiming "pursuit of happiness," as opposed to the slaveholder's notion of "property," being the natural ordering of God's Universe. Such was the notion of Martin Luther King's "I Have a Dream" and "I've Been to the Mountaintop" speeches. Lincoln's intent fell in line, accordingly.

As Lincoln once said, if you have the right to enslave a man because he's got darker skin than your own, what's to keep a lighter skinned man than yourself from doing the same to you? All human beings can love the human mind, through the process of unfolding their own mind, through the implementation of their own creative discovery, as an active force on the Universe. Many Southern ideologues, environmentalists, and others, willfully choose not to take this role in the Universe, never daring to raise a creative, industrial finger to transform the "natural" state of things into something more efficient, better, more human.

Lincoln was no such man. Neither is Lyndon LaRouche, today.

**Wesley Irwin
LaRouche Youth Movement**

Correction

Two editorial errors were introduced into the article by Wesley Dean Irwin, "From Lincoln to LaRouche's Land-Bridge: On the Implementation of Technology," in the Summer 2004 issue. First, on p. 15, a Fourth of July, 1828, speech on subduing the Earth with "internal improvements" was attributed to Lincoln, instead of to John Quincy Adams.

Second, on p. 17, Lincoln's commitment to the idea of railroad development dates to the 1830s, not the 1820s.

In Memoriam

Continued from page 6

Glacier as the "patron saint of hiking."

Edwards was a member of the Sierra Club and Audubon Society, a lifetime fellow of the California Academy of Sciences, and a member of the exclusive Explorers' Club in New York. He wrote ornithological articles published by the Audubon Society, and documented how U.S. bird populations, including bald eagles, peregrine falcons, and other eco-favorites, had *increased* in the years of heavy DDT use.

His first mountaineer training came in the U.S. Army in World War II, and he climbed mountains worldwide, including the Matterhorn (at 76).

He is survived by his wife, Alice, and his daughter, Jane. His unfailing good nature and voice of reason in a time of eco-pessimism will be missed.

—Marjorie Mazel Hecht

THE LIFE AND WORK OF

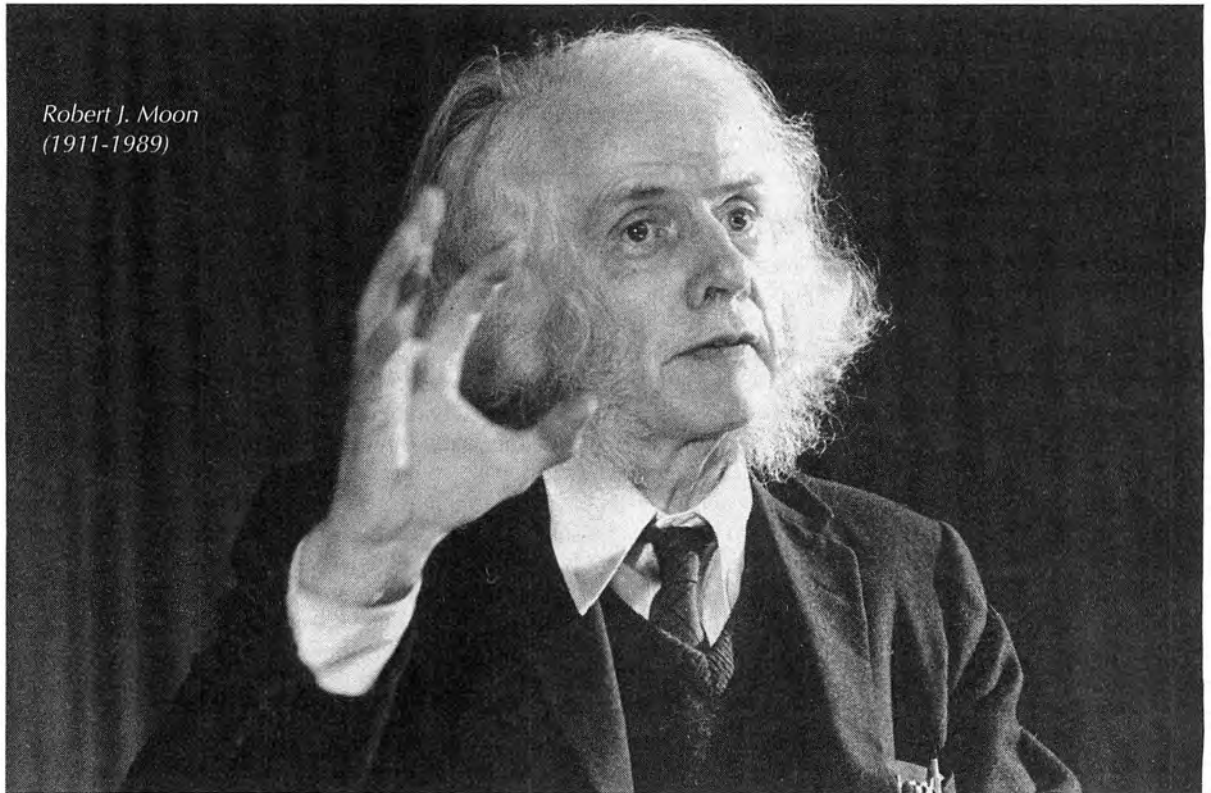

Robert J. Moon
(1911-1989)

EIRNS

A previously unpublished transcript of a presentation by Dr. Robert J. Moon, Jr., Sept. 4, 1987, in Leesburg, Virginia.

Dr. Moon was introduced by Laurence Hecht, saying, "I asked Dr. Moon to give two lectures on the development of his model. The question I asked him to address tonight is: 'How did he do it?'"

* * *

This goes back a long ways, as anything of this sort does for all of us. I was born into this world. It is an exciting world; it's a world in which there are many challenges. So, I was born some time ago: Feb. 14, 1911, when Halley's comet was about, and my mother says she showed it to me. I don't remember it, but I did see it this last time out at the farm [near Leesburg, Va.], with the 8-inch telescope, and I watched it for hours. It was very intriguing, indeed.

Well, now this whole thing begins, I should say, with this sort of thing. All the way through I've been running into various things that are exciting, exciting things to do as you grow up. Even as a youth, I had quite a few exciting things to do. We lived out in the country. We had four cars; there were 10 acres. We had a pig apiece and a cow apiece, each one of us four boys. That may not sound so exciting, but you had to milk them morning and night, by hand, separate the cream. But we did it. That was back in the days when you could put the cream in a can, about 600 feet from the house, on the road. They would come by and pick up the cream—the creamery would—and bring the can back. But, no one would steal it. It was very interesting. Right up there on the road, a nice five-gallon can of cream—good cream—it was from Jersey cows. Then, of course, we had the job of separating the cream, and that was all done by hand, with a De Laval separator.

DR. ROBERT J. MOON

1. Robert J. Moon On How He Conceived His Nuclear Model

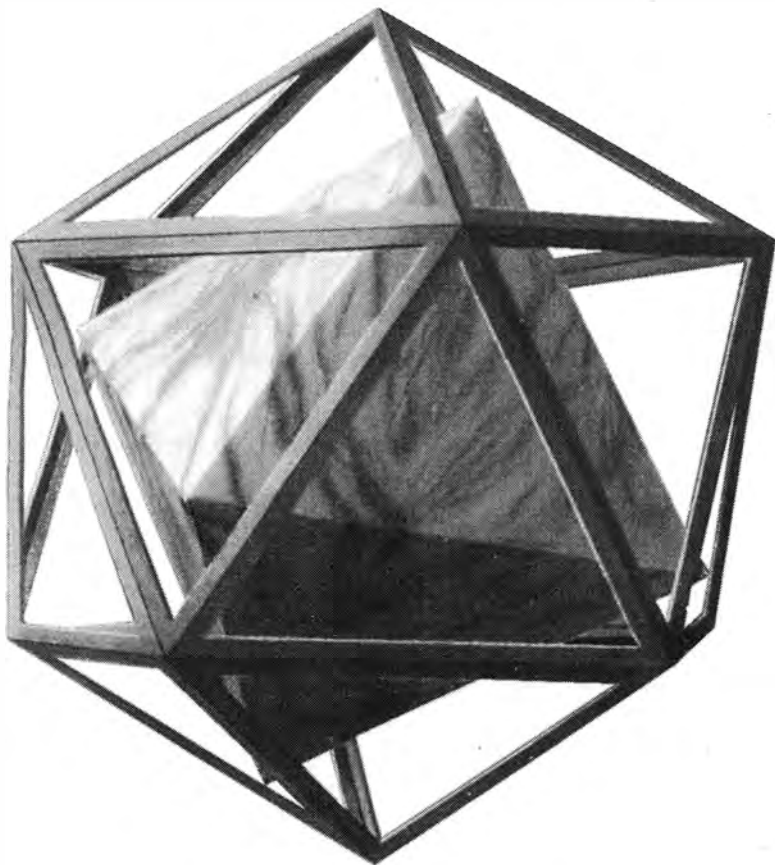

So these are the the sort of things that I grew up with. We had automobiles to repair; batteries to rebuild; generators to rewind; and, a lathe to do some wood turning, because there were a lot of trees on the farm and we would cut them down and turn them into lamps and things like that. So all of these things were a lot of fun.

How Does a Transformer Work?

And one of the mysteries to me, was the thing that really makes electricity possible today, and that was Faraday's law of induction. That was a question, if you have a transformer—did any of you think about a transformer? How does a transformer work? How do you go from 110 volts down to 6 volts, for example, of alternating cur-

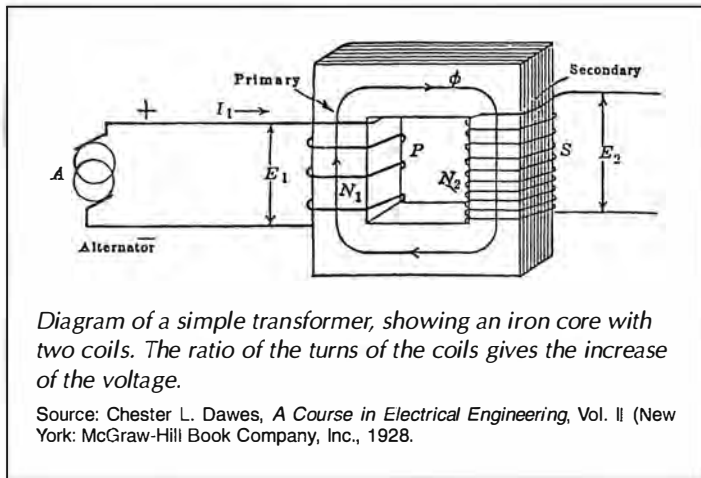

Diagram of a simple transformer, showing an iron core with two coils. The ratio of the turns of the coils gives the increase of the voltage.

Source: Chester L. Dawes, *A Course in Electrical Engineering*, Vol. II (New York: McGraw-Hill Book Company, Inc., 1928).

rent? Well, that was the question I tried to answer [laughs]. I tried to figure out a bunch of relays, first. And then I finally discovered that you had such a thing as impedance—reactive impedance—which didn't use any energy. So, the current could go through the reactive impedance, which was the coil, around an iron core, and outside that was a coil with fewer turns. And the ratio of the turns gave the reduction of the voltage, the ratio of the voltage. So that if you were going from 120 volts down to 6 volts, that would be a ratio of what, 20? So one-20th the turns, but a larger wire. Well, this thing could be turned on all the time, and it didn't use any energy, except when you pushed the doorbell button.

So then I—well, from this you begin building transformers. It's a lot of fun to build transformers. I built one for a lead-burning outfit, in order to repair storage batteries. You had to get a very high current and a low voltage. Anyway, so these are some of things—I think you run into similar things, all of you. I don't mean to say that I am any exception. I just happened to run into these things, and they were all very exciting. Electricity was taking the place of gas, and gas lights, and also the carbon light began to disappear, and the incandescent filament began to take place. Automobiles began to come.

We had an old 1916 Overland. That was another thing. Anyway, I had the problem of repairing it in the middle of the Jordan River—really a creek. You didn't have bridges then, you just ran through the gravel. And it stopped. The car stopped, and so my father went to get some help somewhere [laughs], to find a farmer with a telephone. You know, there weren't too many telephones, and so [laughter], before he got back, I decided that I had better look into it. So I began to analyze it.

Well, these are things all of you do. You probably analyze problems. So I analyzed it, and turned the headlights on and found that there were no lights. So I decided it must be electrical. I began to explore and found that one of the battery con-

nections was loose. I cleaned it up and put it back on, and the lights went on. Then my father came back. He hadn't found a telephone, so I said "Well, I think the car will go." And it did.

Question: How old were you then?

I was about five years old [laughter].

So, anyway, these are the things that run across our paths. There are challenges. We are born into a changing world because as we know now, we can have so many people in this world. And, we got away from the idea of living on a farm, and relying on the weather to produce the food and all. And you didn't know whether you were going to starve, or have an abundance. And then the city came along—and Lyn [LaRouche] has emphasized this too—that a man, working in the city, with ideas, could produce things that would help increase the farm production. And I think we're still in that same period today. We have made a lot of tractors, haven't we? But it seems, somehow, we're not making many tractors, today. And yet we need farming. So I don't think we would want the population to be cut down, do we? But, it looks as though some people may have that idea.

So, anyway, I went to college in my home town. It was very interesting, because I was able to do a lot of things. And I think many of you could do the same thing too, even in today's colleges. If you ask the head of the physics department or a chemistry department or biochemistry department, or what not, to do a few little extra experiments, on your own, and particularly with a lot of equipment that hasn't been used. Try that! Anyway, that's what I was permitted to do. A lot of beautiful equipment was just in the physics storeroom, and that was a great thing for me. Luckily, the laboratory space in the afternoon was all mine, and I could use any of that equipment, and do any of the experiments that I read about. So it was a lot of fun.

And, these are things that I think that come to us. And you see these—I'm talking about the '20s now—I graduated in 1930 from college. But, the things that were going on, that made it exciting, were very much connected with fusion. They were talking about the millennium coming—that's a thousand years of peace and prosperity, in which there won't be any deaths or sicknesses and so on. They were talking about that, and I began to wonder about the energy for the millennium.

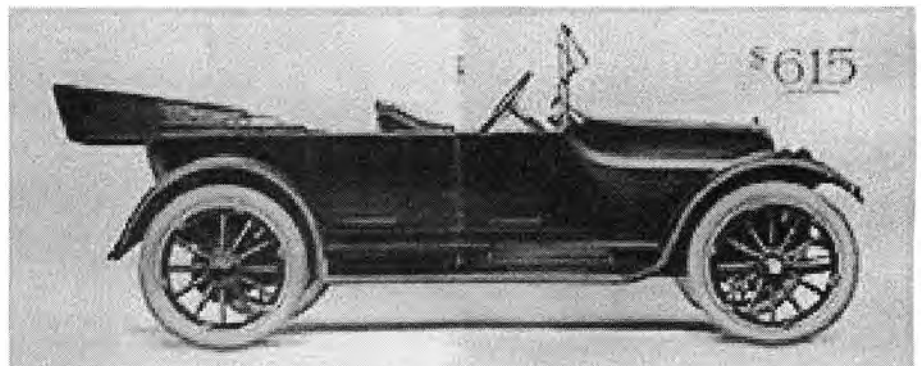

A 1916 Overland from the company sales brochure, at a price of \$615.

They knew about the heat of the stars at that time, in spite of the fact that we hadn't gone so far in physics with it. The chemists had gone far enough. They had determined, just from the molecular weights of hydrogen and helium, they knew that if four hydrogens went together to make helium that you get—there's quite an excessive mass there—and that would go to make energy, and that was the heat of the stars. And this was also shown by the astronomers, who found that the old stars had a lot of helium and little hydrogen, and the young stars had a lot of hydrogen and little helium. So, therefore, the process was hydrogen going to helium; was a nuclear process. And that's what our Sun is and was—I guess it was from the very beginning. But that immediately suggested fusion. And I guess that's been one of the big callings that I seemed to have to do.

Well, then there were a lot of things that happened. I went up to the University of Chicago. And, I don't know: Did many of you go to college, without [applying by letter]? Some of the people I know, write three or four colleges, to get admitted. And then [laughs], they're admitted to maybe two or three of them, and then they finally decide where to go. But then, it was a much simpler process. I began reading the literature—and if you read the literature, you find where the work's being done, in which you're interested. And so, the reason I chose the University of Chicago, was that this Professor [William Draper] Harkins there, had published quite a bit on the neutron—they didn't call it the neutron then. But in 1917, he wrote a whole series of papers [on the neutron]—I have practically all of his papers.

And so that led me to the University of Chicago, and then to come in, and say to the Physics Department: "Here I am." Because Harkins was a physical chemist. And here I was with a design for an experimental fusion experiment: Bring protons in; bring electrons in this way; pulse a magnetic field, and condense the electrons on the protons, and get helium, probably. That was the experiment I had wanted to do for my doctorate. But, Physics said, "Oh, no! Rutherford says that there isn't any more to be learned about nuclear physics" [laughter]. So, as far as Physics was concerned, it turned out that I was the third person to be turned down like that. The first two were Robert Mulliken in 1920, and then Sam Allison in 1925. And here I came along in 1930 and I get the same response. So they were pretty well, they were fairly certain about Rutherford's edict.

Anyway, Harkins took me right away. We started building equipment. I wanted to do the fusion work, but he said we have to get some equipment built, which was right. I knew that. So, the next thing that happened was that I had learned of a particle being, or, behaving like a wave. That was de Broglie, who had presented . . . that as his doctoral thesis. He said that an electron could be a wave, or any particle could become a wave. And, that was exciting to me. At the Solvay Congress [in 1927], he presented a second solution, which came out later to be the quantum potential—I was very much interested in that—to be rediscovered by David Bohm about, oh several years later—about '51, I think it was.

Waves and Particles

So you have all of this excitement about a particle being a wave, not only a wave can be a particle, because the photoelectric effect (how E is equal to $h\nu$ —how a certain frequency can hit a metal, for example, and eject an electron, and that the E was equal to $h\nu$, the energy of the electron minus the contact potential of the metal).

So, there was that, and then there was the Franck and Hertz experiment, which had been done in Germany. I got to work on that as a pastime, where you had the mercury vapor, and here is an electrode—here is a cathode emitting electrons—and the electron is being accelerated, and it falls through this electric field, which is rather uniform. It gains energy linearly, and when it gets up to a certain voltage, there are two things you notice: There is a sudden drop in the current collected; there is also a light emitted. And that light is the beautiful resonance line, the 2,537 line of mercury (2,537 angstroms or .2537 microns). It is a very intense line. You ought to look it up in your spectrographic table, and you will see how intense it is—about 20,000.

And, that immediately showed, you've connected that frequency with the energy that the electron had, and it very



University of Chicago Physical Chemistry Professor William Draper Harkins and his wife, holding the Moons' first child, Mary Elizabeth. They were her godparents.

quickly showed E equals $h\nu$ —it happened there, too. So you had a pretty good, a fairly good determination of the Planck constant. And all along, this is what's been going on, as we—this is the great excitement—because it took so long building equipment, that I ended up building and designing a cyclotron, a 50-inch cyclotron. It weighed about 50 tons, altogether. And [laughs] putting that together—it was the first, really designed cyclotron, and then I did my doctoral piece on electron diffraction, at a very low energy—at 50 electron volts, at the most—from electric circuits, to show the structure of electric circuits, which I found. I found the structure of molecules that way.

Well then, of course, there had been exciting things going on. We had the War, in which we had the Manhattan Project, when we discovered—after we had this cyclotron—we discovered that it was a good source of neutrons, of course.

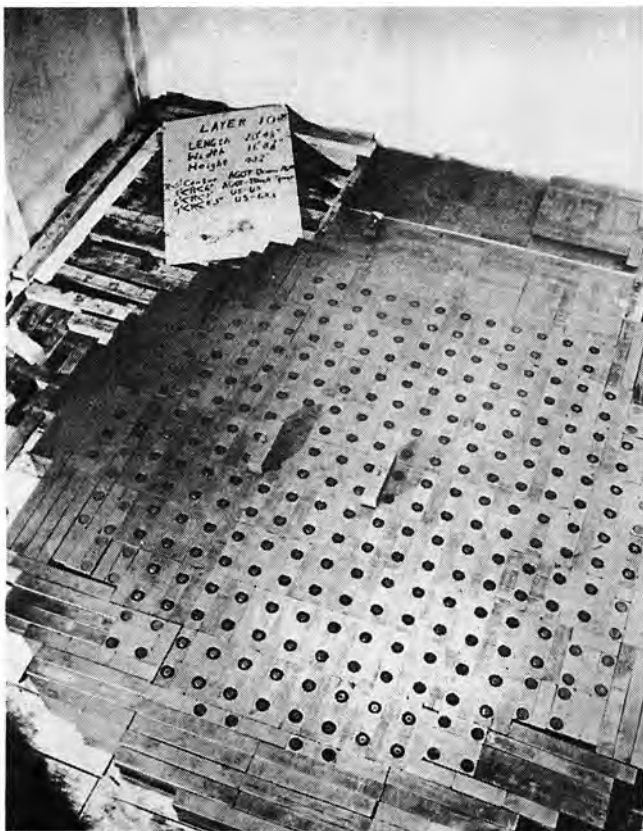

Argonne National Laboratory

The first U.S. “reactor,” the atomic pile at the University of Chicago, produced a nuclear chain reaction on Dec. 2, 1942. A circular pattern of graphite bricks were stacked up in layers. Moon solved the problem of contamination that permitted the bricks to function as a moderator.

Because, if you have a proton with an electron, it becomes a neutron. But a deuteron is a proton and another proton with an electron condensed on it. So it has a mass of 2, instead of 1. But the charged part is left behind, and the neutron goes on, when it hits material media.¹

And this was a way of testing the graphite and other things.² For making a reactor, there were only three things which were available. One was beryllium. It’s a beautiful metal, but we didn’t know anything about the metallurgy of it. No one had produced the metal. It’s very strong and shiny—but we didn’t have enough of that. So, then the other thing was heavy water [Water in which the ordinary light hydrogen is replaced with deuterons—heavy hydrogen]. And we didn’t have enough of that. We had some, but not enough. And so the next thing was [graphite]—Chicago was a great steel-producing center. (It was. But you know, it’s already in the past now. They shut down the Southworks and some of the steel works.) But anyway, the very fact they were making these graphites—they were about 4 feet long and about 4 inches square, and they were rounded at the corners. We tested this graphite. And we used the cyclotron to do it, because, we’d build a pile of the graphite samples we would get, and see how long a neutron would last in that pile, what its life would be.

And that was—to our surprise—finding that very pure car-

bon was obtained from the center. That when they fused the graphite, after they’d pressed the graphite together, and then passed a current through it to fuse it, in a rather huge pile of it, that you had almost pure carbon, I would say very close to pure carbon, in the center; all of the impurities had diffused outwards. And that’s what we used for the moderator in our reactor. This was built on the squash court [under the football field]—they had to stop playing squash [laughs] so we could build our reactor. It was a cubical design. We built it with the graphite on the outside, which supported it, actually, something like a football—I suppose it was very *à propos*, since it was part of the football field [laughter].

The graphite was supported all the way round. If OSHA [the Occupational Safety and Health Administration] had been around I don’t think we’d ever got the thing made, because we had to cut these round corners off, and we did it by using an end-mill on the graphite, so we all came out pretty black. And I’m sure if they knew what we were doing they would have shut us down, if they had existed then.

The Beginning of Fission

Anyway, the pile was built, and the reactor went on Dec. 1, 1942. Now, it seems like I’m getting more on the history of things, but I just wanted to give a taste of how exciting it was. I will say that Aristide von Grösse went over to Germany and talked to Otto Hahn and Leo Strassman, and they were the ones [to discover fission]. . . . And he [von Grösse] brought the message back. And the Physical Chemistry Department where I was doing all my work, now, my nuclear work—we had several meetings over what to do. So we checked out some of the things, and found it really was so, that fission was really taking place, when the neutrons bombarded uranium.

The physicists had all decided never to tell anybody about it. But as soon as that happened, they [the government] gave the \$2 billion for the Manhattan Project, as it was called then. But, I do want to emphasize that, on the whole, we always talked about the spiritual and moral implications of nuclear energy—whether we were ready for it; whether people could take it. We would produce more energy, about 5 million times as much energy per gram of fuel as by combustion. So, that was always a question. And we talked about that all throughout the Project.

And we did *share* ideas. That’s important, in the whole development of anything, the sharing of ideas with one another. We shared three times a week, much against what the Army wanted us to do—General Groves [head of the Manhattan Project], I mean. But, it meant sharing, letting everybody share, regardless of age, or sex, or religion, or race, or anything. And that was very good. You’d be surprised where some of the great ideas came from—they just had to be developed. They came from some of the youngsters!

So, that’s the way we went, and, as you know, we did things in parallel. That’s another factor. We started building Oak Ridge, and started building Los Alamos, and started building Hanford, Washington, all together. We didn’t put them in series (“If this happens, then we’ll do this, and then we’ll do that.”) We did it all together. And it worked very well.

I will say that when the pile got going, it shut down and wouldn’t start up again [for three days]. And that turned out to

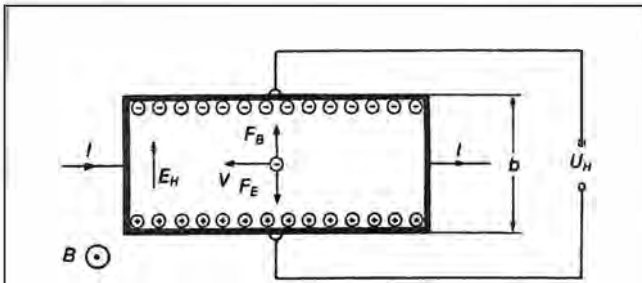

Figure 1

SCHEMATIC REPRESENTATION OF THE HALL EFFECT

Given a conductor through which the current I is flowing, and a magnetic field B perpendicular to the direction of the current and the plane of the current-carrying transistor, the Hall effect describes the deflection of the charged particles sideways, also known as the Lorentz force, F_B . The particles will collect on the edge parallel to the electron velocity (when no magnetic field is present) and move from the opposite edge of the transistor.

This charge separation leads to the buildup of an electrical field E_H (the Hall field). As soon as the resulting force F_E compensates for the Lorentz force, an undeflected current continues to flow. A potential difference U_H is created between these two edges.

be an isotope that had a very high capture cross-section [for neutrons]. It had a half-life of about three days, so it stayed shut down for three days, and then it started up [laughter]. So we learned a lot things that we didn't know about nature.

The von Klitzing Experiments

So, I'll just jump up to things that led up to what we're going to talk about in the structure of this nucleus. And that is, we had a paper by some Germans, [see p. 21] who had looked at the superconductivity—well really we shouldn't call it superconductivity this time, anyway—they were looking at the conductivity in a very thin piece of material which had a couple of electrodes on it, just to keep the current constant [Figure 1]. I [the current] was constant here. The magnetic field, B , was in this direction. Then, I'll draw this in three dimensions, an isometric projection. Then, electrons come over. The electron is bent by the magnetic field, and will make a circle. The electron is coming along, and as soon as it enters the field, it will make a circle. And this will cause a charge potential over here. Of course, as you create a magnetic field, it [the graph of the potential] goes from the straight, and then gradually it bends over more, until finally you reach a plateau.

But anyway, it was this particular experiment—of course, all of this was done at liquid hydrogen temperatures to keep it cool and to prevent the vibration of the particles in the semiconductor, which is a silicon semiconductor. So the current was constant. The I coming in is constant. It was kept constant by these electrodes here [see Figure 1]. And, then what is measured is the current divided by the voltages generated over here.

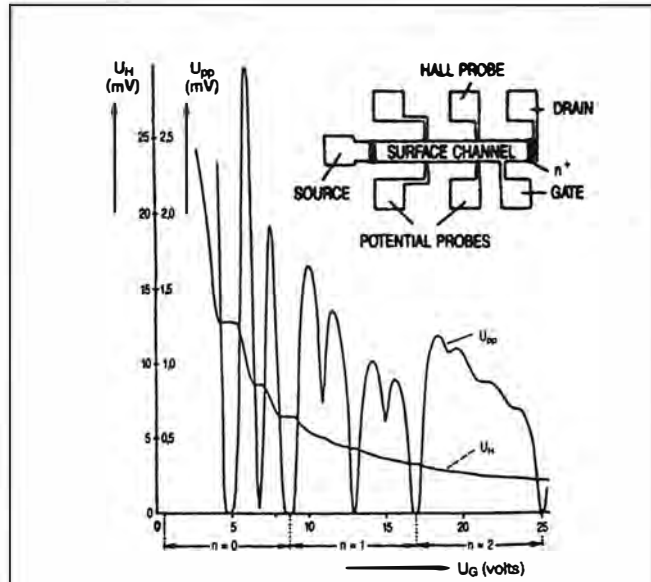

Figure 2

KLITZING'S EXPERIMENTAL CURVE

This is what the grid voltage U_G versus the Hall voltage U_H actually looks like, according to Klitzing's experiment. The plateaus in the Hall voltage can be seen clearly. U_{pp} is the longitudinal voltage, which becomes zero when the plateaus appear. Klitzing first published these results in 1980 in Physical Review Letters.

Well, what this began to show, was, as we plotted the current I as a function of B , the magnetic field, the magnetic induction. Let's not look at the current so much as the voltage in this case, that's generated across. The current is going this way, but the voltage is perpendicular. So, it comes along, and then finally there's a little plateau here [Figure 2]. Then it creates a little more, and there's another plateau. The plateaus get a little wider. Finally another one. It gets a fairly large one up here, and then, there doesn't seem to be any more. So, five distinct plateaus.

And, you begin to look at this, and wonder about it. And [laughs], you say, "Well, this must be because it seems the higher the field goes, no more plateaus seem to occur." Well, this happens because the electron spins. It spins around its axis. This is the electron [draws a curved arrow to indicate spin]. But then there is something more that happens. Not only are the electrons spinning, but this may be a north and a south pole, relative to the current. This is a current rotating, you see; the electron is a charge.

So, actually, you've got another plateau; it should occur up here. So, what, to give you the parameter, is the resistance? Well, you all know Ohm's law don't you? Most of you learn it this way: $[I = E/R]$. So, if you want the resistance, you just say R is equal to E over I . So, you see, you can measure the current, and this is the direction of the voltage this way, and this will be the resistance in this material medium. So, the last plateau occurs at about 12,812 ohms. We'll use an omega for an Ohm sign.

And then you begin to wonder, "Well, what's this plateau?" [Figure 2] And you find that that's . . . well, let me say that these electrons, now, they seem to like each other very well. And so one will spin in the opposite direction. This will be the South Pole, up here. So, the electrons seem to like to go around in pairs, in solid state, and this [plateau] happens to be one [electron] pair. And [when] you calculate this; this turns out to be just half that, which means two pairs. So this is about around 6,406 ohms, something like that. And then down here, this is three pairs—just half of the previous, which would be roughly 3,203 ohms. And so on, with four pairs, and you get down to five pairs down here. And that's about where it seems to stop.

Then you begin to wonder, "What are we really measuring here?" And [laughs], that turns out to be very exciting. It's von Klitzing that did this work. We reported it in both the journals . . . *Fusion*, and the *International Journal of Fusion Energy*.

Anyway, starting with these pairs, then you begin to wonder how many pairs could you go to? Well, you find, if you look at it, that you might even go up to 68 pairs plus one. You know what that would be?

Someone in audience: 137. It's the fine structure.

The Impedance of Free Space

Moon: So that's the way ideas tend to grow, and then it becomes very exciting. And so then you begin to wonder: "Well, why these pairs, and why does this happen?" Particularly since, if you remember, the velocity of light times the magnetic permeability of free space is the impedance of free space. Now there is something very interesting about the impedance of free space. If there's nothing there, you can't dissipate, can you? [If there's] nothing to hit, the energy just keeps there. So this is what we call the reactive component. It's reactive because it does not dissipate. And this equals 376-plus ohms.

And then we have the other part. Now the other part comes from any of these equations. You've got to look into the equations for the fine structure constant, and you see they always involve the ratio 1/137. And actually, I think Bohr originally looked upon it as a ratio of the velocity. He made some calculations, and found that the velocity of the electron in the first Bohr orbit—that is the first orbit that an electron has around the nucleus of a hydrogen atom (of a proton, in other words)—that the velocity of the electron in that . . . you multiply that by 137, and you get the velocity of light.

So that was kind of exciting. And that sort of stuck in my mind for several years. So, immediately you begin thinking: Well, what we're looking at here [in von Klitzing's experiment], this value [the first plateau] is the impedance in material media like the semiconductor. So that seemed to

indicate that these are the dissipative resistances. And, as a result of that, you begin to see something new.

Now, let me give you the real equation here. Because there are so many. I can give you an equation here which may help, a bit. I want to give you a simple one. This is the equation which generally is used here. If we want alpha, which is the fine structure constant—the inverse of it really: Now, you notice you have $\mu_0 c$, divided by 2. (Now you begin to wonder: Why the 2?). And then the other part of it is just e -squared (the charge of the electron) over Planck's constant, times the velocity of light:

$$\alpha = \frac{\mu_0 c e^2}{2h}$$

Now what's curious about it, is there are pairs here. And so when you get this ratio, this turns out to be 1/137. So, you have the impedance of free space coming in, which is non-dissipative, and you have this [impedance in material media], which is dissipative. And so, after going through all the various calculations. . . . (You know, recently we've developed so many things in semiconductors—it just happened in the last two or three years—that we've gotten to the very. . . . In fact, I won't put down the equation that the Bureau of Standards uses, because they wanted to get the closest thing to determining alpha. But that was done in order to get the most precise determination of alpha; that is, the fine structure constant, that have ever been made. And now we even have better ways, as we are going more into superconductors. In a superconductor, this term will be very low—it will be like free space. (In a superconductor, there is no place for them to lose energy.)

Space, and Time, Must Be Quantized!

This then—in fact, it was early one morning—I began to say that, as a result of this, that there must be structure in space. And that space must be quantized! So that's what all these experiments do [laughs]—it starts way back, and many ideas will grow on you all, on everyone here, I'm sure.

Ideas will grow, and you will come to something like this, and then you will begin to wonder. So it was early one morning, about four o'clock in the morning . . . as I reflected on the



EIRNS

Chuck Stevens (left) with Dr. Moon at Moon's 75th birthday party; Louise Howard is at center.

idea of de Broglie on the quantum potential. The quantum potential says that if there is a slit somewhere, and a photon is coming up to it from some direction—or a particle—that particle knows that slit's there! That's what the *second solution of the quantum mechanical equation shows!* Now isn't that strange? [laughter] It doesn't have eyes. And so, that was probably the reason it was rejected in 1927 at the Solvay Congress. De Broglie had closed his books, as I told you earlier.

Anyway, this quantum potential now comes to be a *real thing*. David Bohm is publishing quite a bit on it. And, it simply means—and, this is one interpretation of it—that we have two kinds of time, and [laughs] the secret is that we should have quantization of time for this quantum potential to work. And, in the quantization of time, you would have time move along in *chronos*,—we have *chronos*. That's the time we know, the time you have when you turn on your radio station. *Chronos* [writes word on blackboard], that's man's time. Then there is the other one, *kairos*, which is God's time. These are Greek words. This is God's time. And this is man's time—*Chronos*. Does your alarm clock go off in the morning? And you've got to meet somebody at such and such a time [laughs].

But, anyway, this seemed to be where *chronos* and *kairos* could come in. I don't know how to draw this, because ordinary time will go along like this, as a linear function, and the time is increasing. But then, if time stops, if there was a gap, would we know it? There could be gaps in time right now, and since we're going by *chronos* we wouldn't know it, would we?

But anyway, if you have those periods like this, you have gaps. In other words, you have both the quantization of space—that seems so clear—[draws something] and one is space, and the other is quantization of time. And this is *kairos* and this is *chronos*—I mean, you have two times here, *chronos* time and *kairos* time.

But what happens here in *kairos*? Well, what is the velocity of transmission of information? You know, in biological systems you are taught how this tells that thing what to do. We have people telling others what to do. But, what about *kairos*? This is a very important point.

Question from Fletcher James: Are you saying there would be infinite velocity of transmission, or . . . ?

Moon: Right—or instantaneous transmission. That's right! So if you had instantaneous transmission—I can't say how long it lasts. But, anyway everything stops for, maybe it's a microsecond, maybe it's a femtosecond, or something. I don't know.

But, anyway, instantaneous transmission doesn't require much time does it? [laughter]

So, this means that every particle knows about every other particle in the universe which is exactly de Broglie's idea, and, David Bohm's, who rediscovered it. They worked together on this general idea, up until de Broglie died, early last year, I believe just in the last year.

Anyway, this seems to fit that kind of detail, that we do have a means whereby each and every one of us must, to some extent, must be aware of everything else in the universe. Of

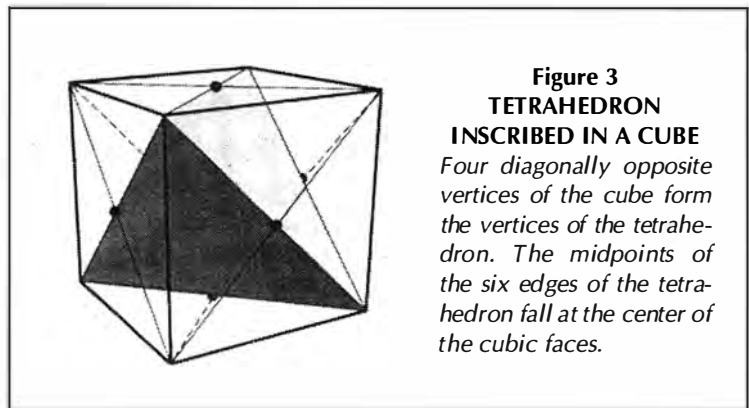

Figure 3
TETRAHEDRON
INSCRIBED IN A CUBE
Four diagonally opposite vertices of the cube form the vertices of the tetrahedron. The midpoints of the six edges of the tetrahedron fall at the center of the cubic faces.

course, we may be aware of it, but we may not comprehend it. That's another thing [laughter].

So, at any rate, this is the situation, I think, in which we live, in which there is a knowledge of what is happening in the universe, even though 155,000 light years away, we had a super nova. And to think that the light coming from it, and the radiation coming from it, would keep together for 155,000 light years. That's quite a distance. Just think how difficult it is to keep together, even if you are walking with somebody, even walking a block [much laughter]. But, here these waves are keeping together. And there seem to be some neutrinos coming along. And the neutrino is a particle. It seems to get here. A few of them did, at least there were seven, I think, at the latest count [laughter].

Quantizing Space with the Platonic Solids

So: The quantization of space and time! That just struck like a bolt of lightning. Then, the next thing that struck was: Well, if space is going to be quantized, it should be quantized with the highest degree of symmetry. And so that immediately said, well, those are the Platonic solids.

And [laughs], so I was pondering over that until the Sun came up. So, I went out to eat at the Summit Hill. And, who should come in to eat, but Chuck [Stevens]. So we had quite a talk about it. It seemed very obvious how these solids should fit. You start out with the tetrahedron. And the tetrahedron fits into the cube. Two tetrahedra fit into a cube.

The tetrahedron has this kind of symmetry, doesn't it? It has two vertices here, and two here. And they are at right angles to each other. So if you put a tetrahedron across this way and one this way [with their edges] perpendicular, the four corners of the tetrahedron would be here [on the four corners of a cube, Figure 3].

But, now we would violate one of the things—the tetrahedron being a very special thing, we allow the two tetrahedra to intersect, so that one is across this way, and one across this way, so that the cube is made up of two tetrahedra. [See Figure 3.]

Anyway, the first tetrahedron just has one particle on it. Now, sometimes it gets a neutron, and that's deuterium, or it may get two neutrons, which is tritium. But they don't have to be at the vertices. They can be on the—well, scattered about—because the neutron has no charge. So then, when two protons are in place, then, of course, you have helium.

Now, I want to say, that with helium—this structure we've known for a long time—. . . among all the elements, there is a periodicity of four. And, if you look at various things—Larry [Hecht] got excited about this. We had just gotten a bunch of books over from the University of Maryland library. And he was excited about it, so he went into the extranuclear phenomena, which describes the *field* that is created by the shape of the nucleus. And you [Larry] have written a paper on that—such things as nuclear volume, ionization potentials, relative abundance, things of this sort, are the things that Larry wrote about. Did I miss any? . . .

Larry Hecht: . . . That covers it [laughter].

Moon: . . . And he did a very good job, and then started building models, too [laughs]. He built a lot of other models.

But anyway, the thing is, that you start with the tetrahedron, and then the cube. [Begins to assemble the Moon model, showing first the cube]. This cube, with a proton at each corner.

. . . Now, there are two things about this, and that is this—these two things are, just: one proton (this is the exclusion principle for face centers)—one and only one. This is an exclusion principle. The protons are on the vertices. Now, we're not worrying about the neutron. We're not worrying about the neutron, because it can go [anywhere] . . . since it has no force on it, really, other than gravitational, it can find places in the structure. So, just imagine a cube now. You know what element this is, now, with four protons up here, and four protons up here? I might say, one thing that suggested that, is if you just made a simple table. There are a lot of exciting things. I don't know how much you want to know about these things, but let me just put that down here. I think most of you know this [draws the following table]:

	Faces	Vertices	Edges
Tetrahedron	4	4	6
Cube	6	8	12
Octahedron	8	6	12
-----	-----	-----	-----
Icosahedron	20	12	30
Dodecahedron	12	20	30

You can do these all yourself. You all know this. I'll just put down the face, the vertex, and the edges. And this is always intriguing. The cube is 6, 8, and 12. Then, the octahedron is 8, 6, and 12. This divides the two [points to separation between octahedron and icosahedron in chart]. Then the icosahedron becomes 20, 12, and 30. Now you know what the next one will be. The dodecahedron is 12, 20, and 30. So you have two sets here, where they exchange, and so that means you can put one inside the other without much trouble. And then, you get several relationships. But the one you probably all know is this one: which is the vertices minus the edges, plus the faces. You know what that equals, don't you? $V - E + F = 2$.

Yes, it's 2; its always 2, for any of these.

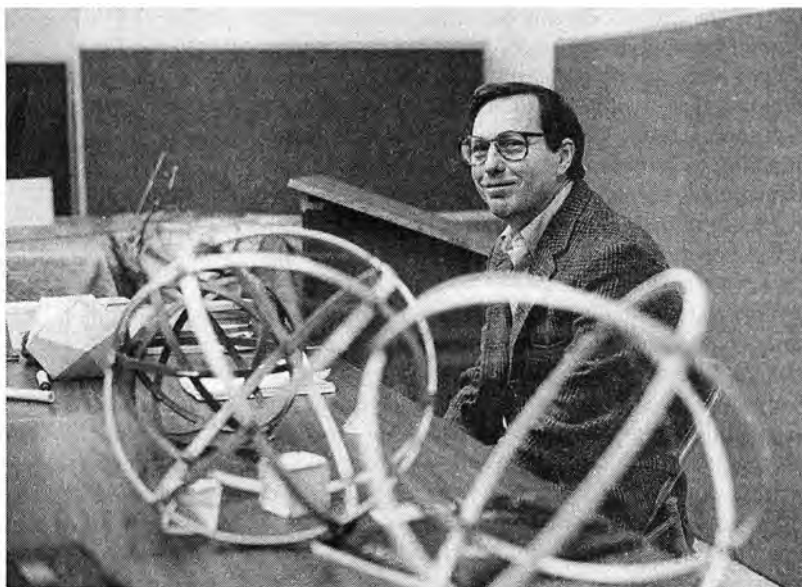

Philip Ulanowsky/EIRNS

Larry Hecht teaching a class on the Moon model in December 1992.

But then, there are others—I don't know whether I should go into it—but, you can also write each of these out separately, Because, let me put down that you can denote this by a p and a q [draws the following table]:

	p	q
Tetrahedron	3	3
Cube	4	3
Octahedron	3	4
Icosahedron	3	5
Dodecahedron	5	3

Now, what is a tetrahedron? It's a (3,3). Now, you can tell me what this means, when I get through. This one [the cube] is a (4,3). These are just numbers to designate it, and from these you can do some very interesting things. And this is a (3,4). Then we have a (3,5) and a (5,3). And, you see what's happening here?

Well, what do we have meeting here [points to first column]? These [p] represent simply the number of edges on the faces of any one of these. Here there are 3; here there are 5. In the cube you have 4 edges. These are triangles. Here you see that three of them are triangles [points to the p column]; one is a square; and this one is a pentagon.

And these [points to q column] are the number of them meeting in a point. There are 3 meeting in a point for the tetrahedron and the cube. And for the octahedron, there are 4; and the icosahedron there will be 5 meeting in a point; and in the dodecahedron, there will be 3.

Now, wait a minute, I've got this backwards. What have I done here? This isn't right, is it?

Comment from class: No, it's right.

Moon: Let me make sure of this. So that, then out of this, if you use the p 's and q 's—I'll just put down one, because I don't think I should go anymore into this. But the number of vertices can be calculated from this number that you assigned, which

simply has to do with what the face is, and the number meeting in a point, in the vertex. And so the vertex will be four times p . And then you have this denominator for all of these: $2p$ plus $2q$ minus pq . [$V = 4p/(2p + 2q - pq)$] So, that'll give you the number of vertices—see if I'm right. Take any one of them. Anyway, you can do this with the edges, and also for the faces. But I don't think I'll go into that anymore; the time is getting short.

Elaborating the Model

But, now let's take a little time, and look further at the model. We've gotten up to this [points to octahedron on chart.] So, you know that the cube will go inside, without any trouble. Because, the number of vertices here—well I'll take this out. [He shows a model of the Platonic solids constructed to the proper relative dimensions of the Moon nucleus. The faces are made from discarded aluminum printing plates, held together with metallic adhesive tape].

You see the cube is nestled there; you see, it nestles very nicely. You can move it around. It's got the cube so the vertices are at the center of these faces. [Class members experiment with model.]

And, while you're doing that, I'll put down here something that has to do with the dimensions. These were all based on the dodecahedron. (I'll just use a D for that.) We used 100 millimeters. George Hamann was very useful in constructing these models. You can cut them out by the gross, can't you, George [laughs]? He took the waste, you see. You know what this is? You know where this came from, don't you?

George Hamann answers: The printing company.

Moon: They threw 'em away, so George caught them, and made these models. Well, we started out with the dodecahedron having 4, and then the sequence is that as you go down to the cube, that the ratio of these two, the dodecahedron over the cube (this is the ratio of the edge)—I use E here, meaning edge. And the best ratio seemed to be, after you begin to figure out all this, the best ratio turned to be the divine ratio. So this is, you all know: 1 plus the square root of 5 over 2 [$1 + \sqrt{5}/2$]. That's the divine ratio, which you know is 1.618, and so on.

So, this then gave us—I'm going to write down here [points table on board]—these are the edges [writes in 100 millimeters for the dodecahedron].

	Edge length (mm)
Dodecahedron	100
Icosahedron	117.1069
Octahedron	131.1048
Cube	61.8033

Then we have 117 (George, you can check me on this; George and I had quite a—we got lucky with this one). This is 117.1069 millimeters. That's for the icosahedron. . . . And then for the octahedron, we came with an edge of 131. Now, notice these edges are going up; the lengths are going up: 131 and .1048. (Can you vouch for it, George? How far can you vouch for it?)

George Hamann: I'll vouch for it to the .10.

Moon: George vouches for it to there [points to second dec-

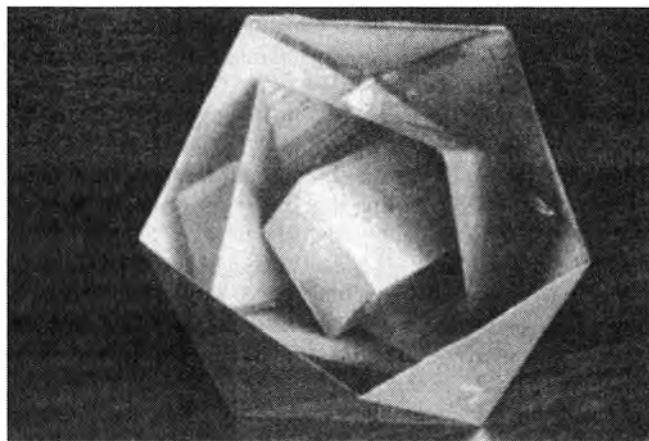

A "Moon model" made by George Hamann from discarded aluminum printing plates.

imal place]. Then the cube turns out to be 61.8033 millimeters.

So, now the ratio, as I say, is this [points to divine ratio]. And they all fit together well. The idea, with the exclusion principle which you have here, with one proton per face center, we now have a structure, which I think I can put together here. Have you got the rest of that model? [Takes model.] This goes inside. You see, now we have the octahedron. Here's where we have the fun. It's figuring out the best symmetry you can have with the octahedron inside the icosahedron. I have the faces off the icosahedron. You see the holes here [points to holes in the centers of six of the icosahedral faces]. This can be nested in here [places octahedron in icosahedron]. And, you can see it has quite a bit of wobble—in fact if you put it in that way, you can't see anything above the top, can you?

But we're dealing with a very peculiar element in this transition. You look at the properties—you might want to try this, moving it around in here, from its place. But the properties are varying very rapidly. [Class members experiment with the placement of octahedron in icosahedron.]

Question from class: What element is that?

Moon: Well, what do we have? We have 8; we just add them up here. This is where we start. There, the cube is 8, and here 6 [from the octahedral vertices] is 14, and now what's the next element? It's element 15, and what element is that?

Class comment: Phosphorus.

Moon: Yes, and phosphorus is so important in living things, too. But it also is one of those things we've got to check to make sure, because all of these things are locked up in the building. [He is referring to the forced bankruptcy of the Fusion Energy Foundation and two other associations connected with Lyndon LaRouche.] But Chuck had his old copy out. But it has a valence of 3, 5, and minus 3. That's the valence of phosphorus.

So, you see, there's another factor that was brought out in this particular design.

Larry Hecht: Do you mean the variable valence?

Moon: Yes, the variable. . . .

Fletcher James: . . . Dr. Moon, I have a fundamental question about what you are doing in filling in the these solids. Are you proposing a structure in which you actually have, quan-

tized within space, a fixed structure, and you have points, particles which are located at rigid fixed intervals from each other within the structure?

Moon: No. You have singularities—singularities in space, particle singularities. . . .

Fletcher James: But at fixed, constant distances from each other? Or are you proposing that this is occurring in a phase space, and that there is a topological equivalence between this nesting?

Moon: Well, no, this is actual space, so there should be a topological *equivalent* to it. But, this is, these singularities in space may have nothing in them. But they're just a place where these particles can go.

So that when you've gotten beyond this [the icosahedron], we have half of the dodecahedron here [Figure 4], and this whole thing [cube-octahedron-icosahedron] can be placed in here, and of course this [the half dodecahedron] will fit exactly on the icosahedron—the icosahedron will fit in here—since there is a one-to-one correspondence in all the faces and all. And this [the other half of the dodecahedron] goes over the top.

Now you know where we are—what element? Do you know what element this is? It has nice symmetry, doesn't it? You know what element? This is palladium. This is element 46. Some of the astronomers seem to think that is one of the building blocks in the universe.

Well, now once you've got this, then how do you go on up in the periodic table? Well, this is the way you do it.

Maybe I should take this one, and build on this one. [Takes the completed dodecahedron with cube-octahedron-icosahedron inside]. So, you begin building particles out here, here, here. You extend from the one face of the dodecahedron, 10 vertices of a second dodecahedron, which will have a face in common with the first dodecahedron.

So that's 10, and now we're at element 56. And then, if you look at the periodic table, you've gone up 10, and now you've got to start building all over, the cube. So you start again [points to inside of the second half-dodecahedron], and you'd be building the cube, and the octahedron. [Builds the second cube and octahedron with the model.] So here we have 14—8 and 6 are the 14, and they're built up in here. Now, what do these 14 represent? There's 10 [points to the vertices of the half-dodecahedron]. You see, our rare earths begin with element 57. So, we start with 46, and we're going up to lanthanum. And there are 14, sometimes they are listed as 15, depending on whether you include lanthanum or not. And this then will represent the filling of the rare earths within [points to the octahedron with cube nested inside].

Then the rare earths will end, say, at 71. And then from 71, we now have the (well, I forgot to put this other [points to icosahedron])—I'm sorry). . . .

Larry Hecht: . . . No, that's right; that comes next.

Moon: . . . It comes *now*, but it has to go inside here—See now, the problem is you've got to see how elements are synthesized by protons passing through—there's a proton flux in the universe, the cosmic rays in outer space. But this is going to build up the elements and they've got to find a parking place [laughter]. And the protons find their parking place at what would correspond to the vertices. And then the neutrons,

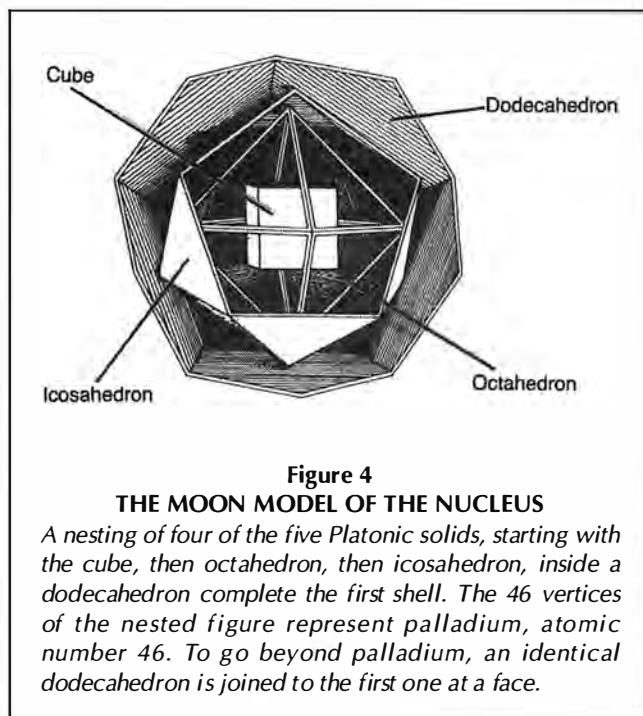

Figure 4
THE MOON MODEL OF THE NUCLEUS

A nesting of four of the five Platonic solids, starting with the cube, then octahedron, then icosahedron, inside a dodecahedron complete the first shell. The 46 vertices of the nested figure represent palladium, atomic number 46. To go beyond palladium, an identical dodecahedron is joined to the first one at a face.

which are also out there, we're not going to worry about them, because they have no charge and they can be most any place. We will begin to worry about them later on.

But this builds up the rare earths, and then from here—is this the right one?—yes, we'll put this cover on here [puts in icosahedron and laughs]. This goes on top of this [places remaining half of dodecahedron on top to close the structure, Figure 5(a)]. And here we are. Now, you know what element you're at?

Radon! Did someone say that? Radon, a noble gas.

Now then, where do we go from here? How do we get another proton in. Every face here is filled with a proton, at the center, and the vertices have protons on them. Where do we go from here?

Hecht: Some of them know, but they won't say [laughter].

Moon: How about this? Turning up like this [he opens the two dodecahedra, using a common edge as if it were a hinge, Figure 5(b)]. Now you see what we have? We have one proton here, one proton here, but there are two vertices coming down, you see [points to the "hinge"]. In other words, we have only one there, but now it can fold out like this on an edge. Now the one proton that shared these two points [the vertices which were closed together but now are opened up] may stay with this, or it may stay with that [points to the two now-separated dodecahedra]. And the same thing over here.

Now, what element is it that follows radon? It's an element that doesn't exist in nature. And it doesn't exist, because it doesn't live very long: francium. We have made it in nuclear reactors by bombarding elements with neutrons. But then, you see, you have this situation happening, and two more will go in. Then, as we develop this, then we get to—uranium will be like this—one vertex [holds up model with the two dodecahedral pieces connected at only one vertex]. But, we can't violate the one proton per vertex that this would be. So the one proton goes inside, and the other goes inside here. [He indi-

cates the one vertex displacing inside the other.]

Can you picture that? One proton in like that, and it makes a sort of hook like this [demonstrates two fingers hooked within one another]. Have you got the idea? And now what we have is something that's ready for fission. See? This thing is not very stable. It's only held in this point. So if you try to put more neutrons in there, it's going to fissh [laughter]. It's going to break apart. Now it won't break apart exactly in half, because it depends on where these other protons are going to go in the shuffle. But, that describes the beginning of fission; that can take place because we can now join two of these building blocks of the universe together at a corner.

Chuck Stevens: Would you say the phosphorus is like a register shift, or like an asteroid belt?

Moon: It could be. It comes at that place [laughs]. It comes at that place, all right.

But this will give a distribution. You know, the distribution of the elements that are formed from the fission is like this [shows a curve with valley]. None of them are exactly a half, apparently, or at least we don't find many there. . . .

Now, just one more little thing, and that is: Supposing this assembly here, uranium. . . . You know that if you put three more neutrons in, and you know what happens there, don't you? You get uranium-238. But now, try to put another one in. And the neutrons don't like so many newcomers [laughter]. They won't allow it to come, to be part of it. So the thing that happens is, it gives off an electron. So that now goes to the next element, which is the next one to our most valuable element for fission—I guess most of you know that's plutonium. What's the one that comes before plutonium? You know your planets, don't you?

Voice in class: Neptunium.

Moon: Neptunium, yes. So, you have neptunium, and then it breaks down again, and you go to plutonium. So that's the way plutonium happens to be made, just by getting too many protons in. So there's a proton-neutron balance.

Well then, I just want—how am I doing, should I stop here? I had just one thing to talk about. Maybe it would be of importance in the nucleus, and that is the . . . magic numbers. Maria Goeppert-Mayer named them the magic numbers. Have you ever heard of them?

Larry Hecht: Well, I just realized it's 11 o'clock. Maybe we should pick that up in the next class. It's probably a good place to stop.

Moon: Well, I will say just—it's the only thing I will say—these magic numbers [laughter] fit the model! [more laughter, and applause]

[The discussion continued after the class, but the audio tape picks up in mid-sentence.]

Chuck Stevens: . . . the icosahedron. Did you at all think about this thing of the ratio of the golden section?

Moon: Yes, oh yes. That was the thing. We could change the

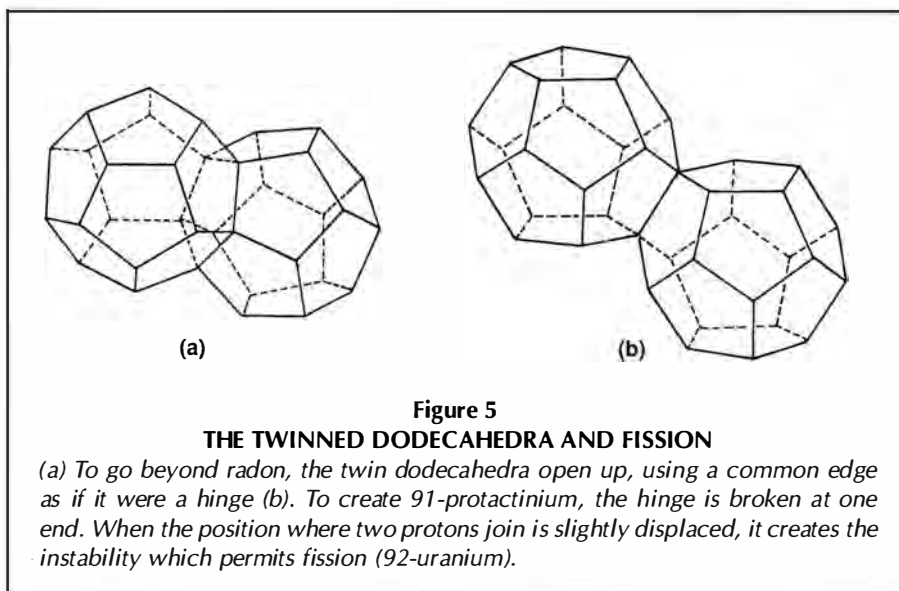

Figure 5

THE TWINNED DODECAHEDRA AND FISSION

(a) To go beyond radon, the twin dodecahedra open up, using a common edge as if it were a hinge (b). To create 91-protactinium, the hinge is broken at one end. When the position where two protons join is slightly displaced, it creates the instability which permits fission (92-uranium).

dimension to that different one. But it also turns out—unfortunately, I don't have the calculations, because they're over in the Fusion Energy office. . . .

Stevens: . . . confiscated. . . .

Moon: . . . Yes. . . .

Question: The way I understand this is not so much structures, per se, but something like the experiments we were doing with soap bubbles, with the least action principle, where. . . .

Moon: Oh, least action, right. . . .

Questioner continues: . . . where you get what appears to be a structure within the wire. But it's not like a physical kind of structure, per se. In other words that's how these things form—how the protons are added on?

Moon: Right. That's how the protons are added on. They can go in the center here. But this is just a means of showing it. . . .

Questioner continues: Right, right. When you're building up past the 46, and start going to the rare earth elements—when you have the cube and then the icosahedron, do you have significant elements at those points, just like, with the cube, what is it, oxygen, when you have the cube?

Moon: Yes. Once it's built up to this—that's 10. You see that takes us from 46 to 56. Then you see, with 57 we begin to see that these are the rare earths here, which begin at 57. And you see, that's exactly what we have. We have 10 and we're at 57, so now we begin to build up the rare earths, which are the 14. This part goes in here [places cube-octahedron combination inside second half-dodecahedron], which has 14. And these are the rare earths, which seem to have—in other words, what is happening here is that the shape of the electric field around this is elongated and somewhat different, and there's still a bit of unfilled spaces here. So that the first set of rare earths are given by this. You see, you've got to remember, we're building from the outside in, not from the inside out, like you did originally.

Larry Hecht: You know, I had a zany idea, while you were talking. What if . . . well, the first time through, we were having this problem of trying to decide what the size of this should be. Could it actually be different the first time through than the second time through? In the first 46 you've got phosphorus, but

you don't have that rare earth phenomenon. . . .

Moon: No. . . .

Hecht: . . . Maybe the icosahedron would be one way the first time through—it would go in there one way the first time through, tighter or something—and maybe the second one is different, so the thing is not perfectly balanced. Maybe that helps account for the way it fissions."

Moon: It may well do that, because, in the fission of uranium, you'll see that the peak is off to the side of half the value—around 46—on either side of it. They go up like this [shows valley curve] . . .

Hecht: Oh, they peak on both sides?

Moon: . . . They peak on both sides.

Hecht: There isn't one point at which it's. . . .

Moon: No. It peaks on both sides. So you can see that uranium has quite a shake-up. And that's the result of trying to add another neutron. That's uranium-235, that is. Of course, -233 fissions also. That we get from thorium, and that's what the Candu reactor uses—they use thorium going in one way, and uranium going the other way. They use heavy water as the moderator. This is the reactor used in Canada, and in India.

Mel Klenetsky: Will this show up in any kind of way—I mean is there any way to measure this? You have spectrographs to analyze things, but obviously it's not fine enough to pick up something like the energy flows. But it seems to me that this kind of configuration would yield some kind of an energy flux that you would be able to measure in some kind of way. . . .

Moon: Well, that's why . . . we're going to talk about the factors because of magic numbers and we're reaching the point where. . . .

Klenetsky: . . . Because the whole thing we were talking about in inertial confinement, in terms of, if you're beaming, if you're taking certain beams in—you and I were discussing this a long time ago—there's a certain way you can match up these beams, certain angles, which are going to give you more of an optimal impact than others. . . .

Moon: Right.

Klenetsky: . . . And it seems to me that this structure lends itself to giving more insight into that.

Moon: Well, maybe, polarization is becoming very important, which we know it is—polarization of the magnetic field, for example, Yes, well, and then these magic numbers change the nuclear properties by a factor as small as you want. It's very sensitive to that. And then Larry's paper shows how this nuclear charge is affected by the—you went into that in your paper, didn't you?

Larry Hecht: . . . Yes—

Moon: . . . Nuclear volume, and things of this sort. In other words, the extranuclear electrons are really showing what's inside. Although it's not nearly as remarkable as the magic numbers are, which show how *nuclear processes* work—though they're both showing it. . . .

Klenetsky: The thing I think that we should be able to do is refine this, to get a much better reading of the molecular structure at the microscopic level, which you don't have. I mean, the basic way that we're dealing with the fusion reaction is fairly primitive at this point. A lot of energy, and you're just squooshing things together, and you're just trying to jumble things up, you know, in a very arbitrary kind of way; and the

point is that if you have a sense of the geometry, this should give us a much better way of approaching this, a much more sophisticated way.

Moon: Yes, and I think too, that when you use this to bombard uranium on uranium—then, there's a certain energy which goes into it, and this fine structure property comes in very beautifully. Because there's a paper written, and you don't know what the answer is to it—but when this hits another uranium, then it goes to element 184 [see p. 24]. Well, they tried all combinations, as you go from 180 to 188, I believe. But the thing is that this energy is divided—1/137 of the bombarding energy, as we show here [points to blackboard]³—you see, this is the impedance of free space, which is reactive, which means . . . it's non-dissipative. And, therefore, calls for the conclusion that therefore this energy cannot be used for *binding*. And it's only this part that can. So, therefore, when they come up, there's immediately established around it, a first Bohr orbit, a virtual, first Bohr orbit.

Now, what can it do? There's nothing there, but there has to be something there. So, a positron-electron pair is produced, and the positron is thrown out. But the energy that throws it out is this [points to blackboard]—and that turns out to be—it's just the right fraction of the bombarding energy, they showed. So, this is the reactive energy, and that goes into an electron that goes off, and it's. . . .

Hecht: . . . The first bracket, the first parentheses [Zmc^2]? That goes off—

Moon: Yes, the first parentheses. . . . That energy goes off. . . .

Hecht: . . . The second part is what can be used for binding? I couldn't see what you were pointing to.

Moon: Yes. So that's 1/137 of the energy. That's what we're talking about.

Hecht: e^2/hc ?

Moon: Yes, that's the 1/137 of the energy that has to be reactive. And so that can carry the electron on it. Maybe that's the way it was meant. I don't know. Maybe that's part of the idea of the fine structure constant.

So all the elements they've made by this, all of which add up to something between 180 to 188. They find that the electron comes out—it's the same fraction of the bombarding energy, about 300,000 volts. Isn't that interesting? And that this gives the result, directly.

Hecht: So that is the Darmstadt . . .

Yes, the Darmstadt experiment. . . right.

Notes

1. If you accelerated deuterons in the cyclotron (a deuteron is a "heavy" isotope of hydrogen whose nucleus contains one proton and one neutron—the neutron is really a proton with an electron condensed on it—as opposed to ordinary, "light" hydrogen, whose nucleus contains just a single proton), you find that the charged part of the nucleus, the proton, is left behind when the accelerated deuteron beam passes through a material target. Thus, only neutrons emerge from the material target. [Charles Stevens]
2. In particular, how neutrons interacted with the carbon nuclei in graphite. This was most crucial for the development and realization of the first nuclear pile, the first nuclear reactor, which was built at the University of Chicago. At the time of the Manhattan Project there were only three things available for making a nuclear reactor (for containing the neutrons produced by uranium fission so that more neutron-induced fission reactions could be generated. [Charles Stevens])
3. The missing equation probably is:
 $E = (Zmc^2)(2\pi e^2/hc)$. Cf. Erich H. Bagge, "Low Energy Positrons in Pair Creation," p. 24. [Laurence Hecht]

What Was the von Klitzing Experiment?

by Ralf Schauerhammer

The von Klitzing experiment was one of the key stimuli to Moon's development of his nuclear model. This article appeared in the May-June 1986 issue of Fusion magazine, and was adapted from a longer piece published in the German-language Fusion.

The Nobel prize for physics was awarded in 1985 to Klaus von Klitzing for his experiments revealing quantization of the Hall resistance. Klitzing also has done a series of experiments that showed the quantization of the Hall effect.

Although this latter result was anticipated and then measured in the 1960s, Klitzing has succeeded in demonstrating the effect with great clarity. The fineness and precision of his experiments have, in effect, allowed him to replicate the first Bohr orbit, and in this way achieve a more precise determination of the fine structure constant.

Klitzing investigated the surfaces of semiconductors under extreme conditions—low temperatures and high magnetic fields. In these studies he used the Hall effect, discovered in 1879 by the American Edwin Herbert Hall. This effect is customarily employed to determine the conductivity of metals and semiconductors and to measure magnetic field strength.

The Hall effect appears as a new, transverse electrical potential, which is generated when an electrical cur-

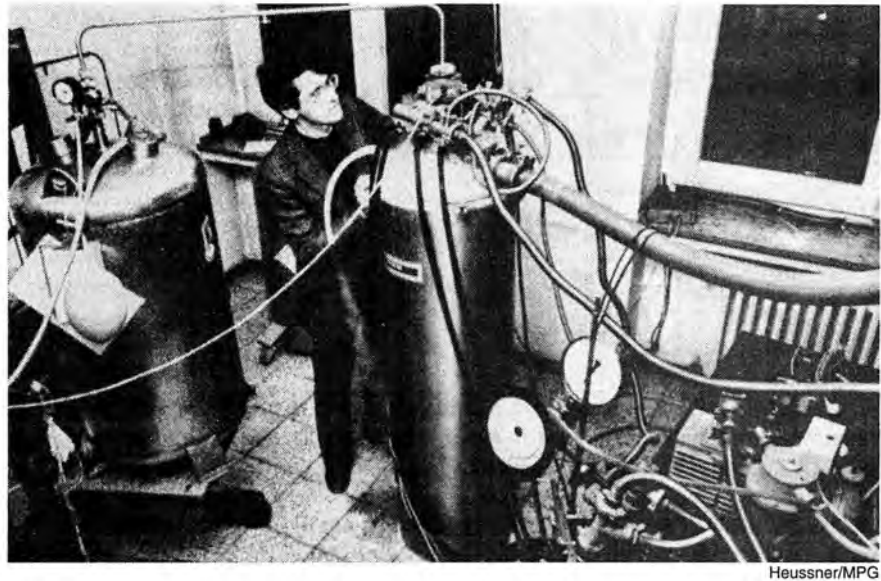

Klitzing with his experimental apparatus in the physics laboratory at the University of Würzburg.

rent flows in a conductor that lies in a plane perpendicular to the magnetic field, as illustrated in Figure 1. It occurs as a result of the deflection of electrons passing through a magnetic field. The electrons are separated from the positive charges creating an electrical potential between them (the Lorentz force, $e\mathbf{V} \times \mathbf{B}$, where e represents the charge, \mathbf{V} the rate of flow, and \mathbf{B} the strength of the magnetic field). This effect is enhanced if the conductor is wide, thin, and long so that the electron gas is constrained to an

approximately two-dimensional flow.¹

The Hall effect can be thought of as a by-product of cyclotron frequency, if it is kept in mind that in the normal situation the full cyclotron rotation cannot take place because of the limitations of the conductor size. Therefore, the potential will build up between the edges, which are parallel to the direction of the current flow in the conductor. Electrons will be built up on one side of the conductor as they are driven over from the other.²

The Hall effect also occurs in the ionosphere, the Earth's "upper" atmos-

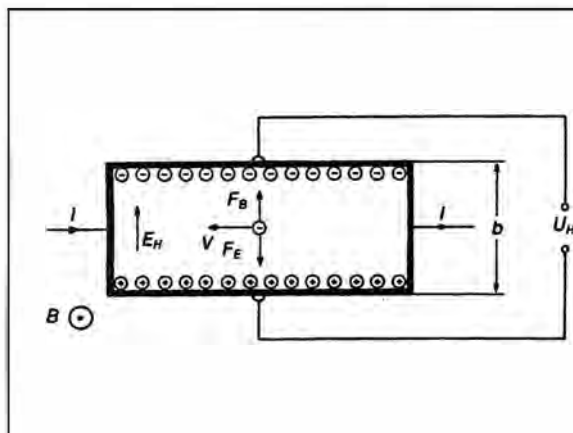
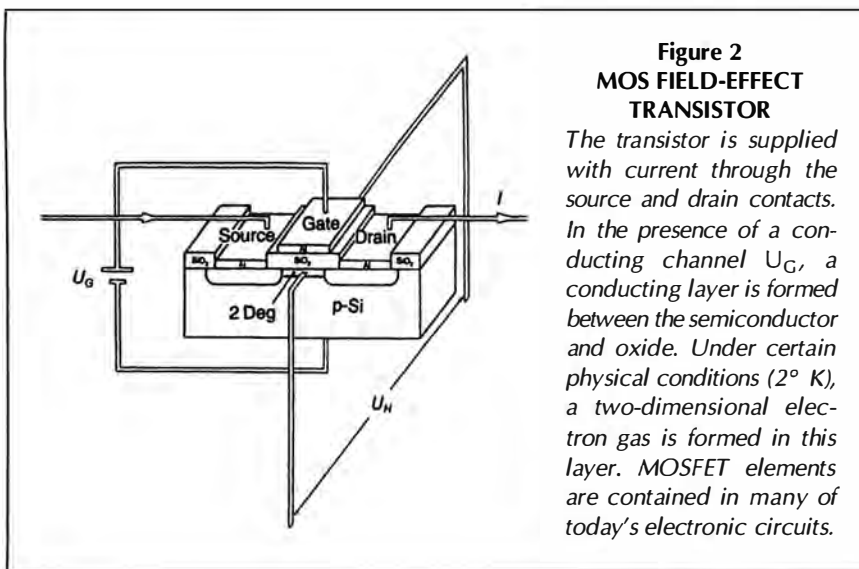

Figure 1
SCHEMATIC REPRESENTATION OF THE HALL EFFECT

Given a conductor through which the current I is flowing, and a magnetic field B perpendicular to the direction of the current and the plane of the current carrying transistor, the Hall effect describes the deflection of the charged particles sideways, also known as the Lorentz force, F_B . The particles will collect on the edge parallel to the electron velocity (when no magnetic field is present) and move from the opposite edge of the transistor.

This charge separation leads to the buildup of an electrical field E_H (the Hall field). As soon as the resulting force F_E compensates for the Lorentz force, an undeflected current continues to flow. A potential difference U_H is created between these two edges.



**Figure 2
MOS FIELD-EFFECT
TRANSISTOR**
The transistor is supplied with current through the source and drain contacts. In the presence of a conducting channel U_G , a conducting layer is formed between the semiconductor and oxide. Under certain physical conditions (2° K), a two-dimensional electron gas is formed in this layer. MOSFET elements are contained in many of today's electronic circuits.

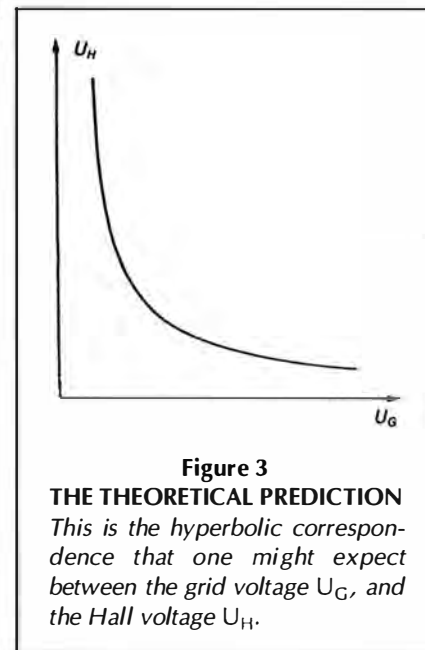

**Figure 3
THE THEORETICAL PREDICTION**
This is the hyperbolic correspondence that one might expect between the grid voltage U_G , and the Hall voltage U_H .

phere. Here the magnetic field is supplied by the Earth. The electrons will resonate with a radio field at the frequency of 1,414 kilocycles, well within the broadcasting band.

The key to the cyclotron, of course, is that the frequency of rotation of the electrons will be constant (within relativistic limits) in a given magnetic field. This frequency, normally denoted as ω , will equal the velocity, $V/2\pi R$, where R is the radius. The point of the experiment in quantizing the Hall effect is to gradually increase the magnetic field, thereby raising the orbital frequency of the electrons in quantum jumps and determining that the buildup of the transverse electric potential, the Hall effect, occurs in a series of discrete jumps, rather than smoothly.

In 1958, experimenters worked with the superconducting alloy indium antimonide, one of the alloys typically used in the manufacture of superconducting magnets, at temperatures of 1.7 degrees K. However, the temperature must be at least 77 degrees K in order for the Hall effect to appear, because of the dampening of the thermal kinetic energy that would otherwise obscure measurement. Another key requirement is for a sufficiently low space charge—that is, density of charge—in order that random collisions are minimized and the electric field is homogenous.

These experimenters were limited in 1958 by the semiconductor materials then available, which were too thick. Klitzing was able to take advantage of today's very thin transistor material in order to achieve

his superior results. The extremely thin MOS field-effect transistors (MOSFET) he used are sketched in Figure 2.

The normal expectation is that a hyperbolic curve could be plotted showing the gate potential against the Hall effect. The number of charge-carriers e available to the current in these transistors grows proportionally to the gate potential U_G . The hyperbola shown in Figure 3 is what would be expected if U_H were plotted as a function of U_G . Contrary to all expectation, no such smooth curve exists. The curve shown in Figure 4, experimentally determined by von Klitzing, deviates from the curve shown in Figure 3 by its characteristic plateaus.

The Quantum Hall Effect

The experiment was performed under very strictly determined conditions. The MOSFET was cooled to about 1.5 degrees K (-272 degrees C). At this low temperature, the kinetic energy of the electrons in the conducting layer of the transistor is so small, that the electrons are unable to move perpendicularly to the electrical field. This condition of restricted degrees of freedom of electron oscillations is termed a two-dimensional electron gas.

Klitzing also used an unusually strong magnetic field in his experiment—180,000 gauss. This is about 400,000 times the strength of the Earth's magnetic field and almost the same order of magnitude as is found in the atom. This strong magnetic field forces the electrons of a two-dimensional electron gas into closed paths. Just as in the atomic nucleus, only a definite number of rotational

states are possible, and only a definite number of electrons can belong to the same state. (The rotational state is called the Landau level, whose maximum number of electrons is $n_L = e \cdot B/h$, where h is Planck's constant.³ If p Landau levels are occupied, $n_p = p \cdot e \cdot B/h$. In this case, the Hall resistance is $R_{HP} = 1/p \cdot h/e^2$.)

In addition to the Hall effect, which measures the transverse potential developed between the two edges of the semiconductor, there is also the Hall, or magneto, resistance, which in effect is a lengthening of the path the electron must travel to reach the boundary of the conductor. The resistance increases as the magnetic field is increased (by introducing an added degree of rotational motion to the electron around the field lines), and it decreases with increased electron density. If the magnetic field is increased sufficiently, ultimately the electron flow will simply be cut off.

Klitzing was able to determine that there is a "natural resistance," which is solely determined by the ratio of Planck's quantum of action divided by the square of the electron charge. This figure, 25,813 ohms, when divided by the Landau level exhibits very sharp quantum plateaus.

His very sharp experimental result, showing the quantization of the Hall resistance, was possible because he was working with an extremely thin transistor and with a high magnetic field. He was able to demonstrate that when the elec-

trons are restricted to a plane, electrical conductivity depends solely on two elementary physical constants, Planck's constant and the charge of the electron.

This simple result came as a great surprise, since it had been assumed until now that the conductivity of a two-dimensional electron gas in a magnetic field would depend on a number of constants, such as the magnetic field strength, the characteristics of the semiconductors used, and the geometry of the design of the experiment.

Instead, one finds only a "natural resistance" that appears in the characteristic interval of $R_{HP} = 25,813/\rho$ ohm,⁴ whenever the concentration of charge-carriers is increased in a fixed magnetic field or the magnetic field is increased in a fixed concentration of charge carriers. Figure 5 shows the results of an experiment carried out by the Federal Physical Technical Institute in Braunschweig. In this experiment, the magnetic field was varied, unlike Klitzing's original experiment (Figure 4), and the "steps" of the plateaus of the quantum Hall resistance are brought out very beautifully.

It is also surprising that the value of the quantum Hall resistance (except for the factor of the speed of light) is the same as the fine structure constant, α , first determined by physicist Arnold Sommerfeld in Munich in 1916. Sommerfeld introduced the constant α in an attempt to remove some of the cruder inadequacies

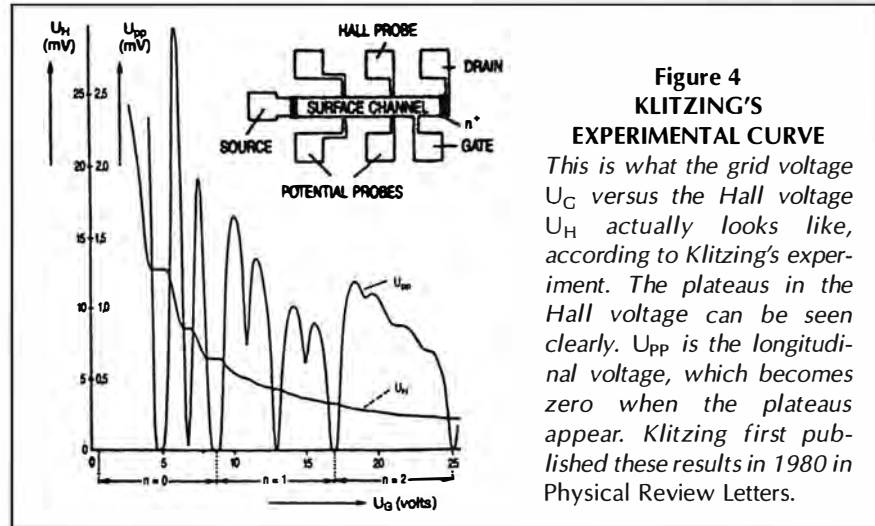

Figure 4
KLITZING'S
EXPERIMENTAL CURVE

This is what the grid voltage U_G versus the Hall voltage U_H actually looks like, according to Klitzing's experiment. The plateaus in the Hall voltage can be seen clearly. U_{pp} is the longitudinal voltage, which becomes zero when the plateaus appear. Klitzing first published these results in 1980 in Physical Review Letters.

of Niels Bohr's planetary model for the atom. Bohr's model corresponds neither to the line spectrum of atoms with large atomic numbers, nor to the splitting of the spectral lines in the so-called double-lines. His model allows only circular orbits for electrons. However, since Kepler's time, such an assumption for the motion of a particle around a central body must be seen as totally arbitrary.

Sommerfeld came upon the concept for the electron motion in the general Keplerian orbital form of the ellipse, in which the orbital velocities reached in the vicinity of the nucleus make a relativistic correction necessary. This has the consequence that the orbits are no longer

closed ellipses, but become rosette-curves when rounding the perihelion. This model gives a nearly exact interpretation of the experimental doublets.

Thus, the fine structure constant is of crucial importance for the entire concept of quantum physics. Its value is about 1/137, which is also the ratio of the velocity of an electron at the lowest level in a hydrogen atom, to the velocity of light. Using von Klitzing's method, α 's value can be measured now to the millionth place.

Notes

1. With b as the width of the conductor in the direction in which the electrostatic field E_H is generated by the Hall effect, and V for the velocity of the electrons, the force acting on the electron is $F_E = e \cdot E_H$ and $F_B = eV \times B$. The magnitude of V is given by the strength of the current, since this is exactly the number n of charges e , which flow through a cross-section of the layer of width b in a unit time. Thus, $I = n \cdot e \cdot b \cdot V$ and $V = I/(n \cdot e \cdot b)$. This expression results directly in $U_H = b \times E_H = B \cdot F_E/e = B \cdot F_B/e = b \cdot V \times B = B \cdot I/(n \cdot e \cdot b) \cdot B$.
2. The constancy of the cyclotron frequency is determined by equating the Lorentz force with the centrifugal force, where m equals the mass, e the charge of the electron, V the velocity, R the radius, B the magnetic field, and ω the angular frequency. Thus, $eV \times B = mV^2/R$. $eB = mV/R$; $eB/m = V/R = eV \cdot 2\pi$. This gives the result $eB/2\pi \cdot m = \text{Frequency}$. For this effect to be sharply measurable it is necessary to have a strong magnetic field, but also to work within a sufficiently narrow radius so that the quantization of the velocity is large enough, relative to the velocity, to be measurable. Since Klitzing concluded his experiment, other experimenters have obtained similar results by etching circuits of a fraction of a micron diameter, even in thin copper. This would be like a minute washer.
3. It is $n = \text{state of density times energy interval}$, whose state can be reduced to a Landau level. Thus, $n_L = m/(\theta \cdot \pi^3 \cdot h^2) \cdot 2\pi \cdot h \cdot \omega$, where $\omega = e \cdot B/m$, which is the cyclotron frequency.
4. The value of 25,813 ohms is easily calculated. It is $h = 6,625 \cdot 10^{-34} \text{Jsec}$ and $e = 1.6020 \cdot 10^{-19} \text{C}$. $\text{Jsec}/\text{C}^2 = \text{J/C} \cdot \text{A}$ results exactly in the ohm unit.

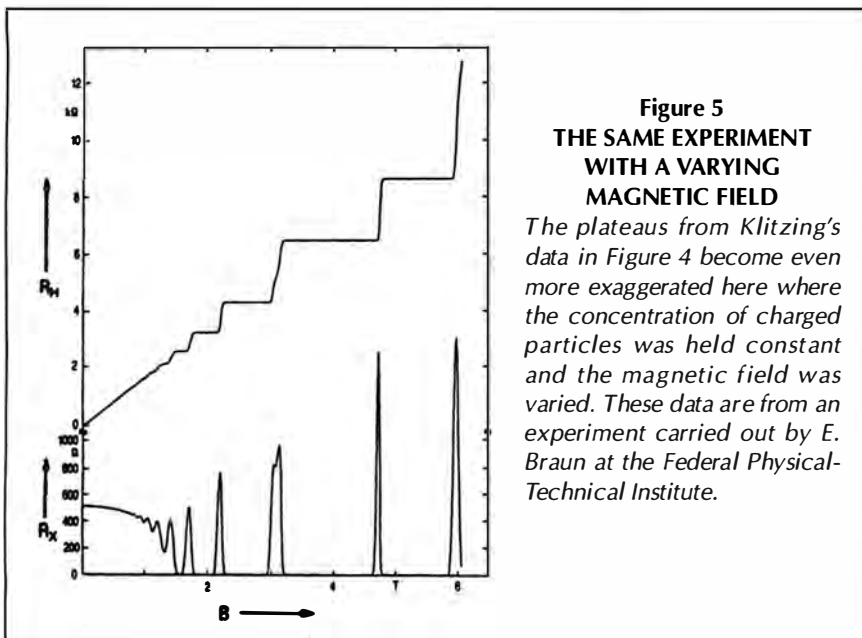

Figure 5
THE SAME EXPERIMENT
WITH A VARYING
MAGNETIC FIELD
The plateaus from Klitzing's data in Figure 4 become even more exaggerated here where the concentration of charged particles was held constant and the magnetic field was varied. These data are from an experiment carried out by E. Braun at the Federal Physical-Technical Institute.

Low-energy Positrons in Pair Creation

by Erich H. Bagge

Dr. Erich Bagge (1912-1996), a student of Werner Heisenberg and Arnold Sommerfeld, was a pioneer of the nuclear energy industry in West Germany and the designer of the world's first nuclear-powered commercial vessel, the Otto Hahn. He was director of the Institute for Pure and Applied Nuclear Physics at the University of Kiel and a member of the West German Atomic Energy Commission. Bagge's ideas on pair production contributed to the Moon model.

This article originally appeared in the May-June 1986 Fusion magazine.

In the November 1985 issue of *Physics Today*,¹ Bertram Schwarzschild reports on "puzzling positron peaks appearing

in heavy ion collisions at the Society for Heavy Ion Research at Darmstadt in West Germany (GSI)." There is also a discussion of experiments to explain the intensity peaks of positron energies between 300 and 400 keV.

Erich R. Bagge, Ahmed Abu El-Ela, and Soad Hassan have reported in several places,² on measurements of pair creation of positrons and electrons that were triggered by gamma quanta of 6.14 MeV, at their passage at nuclei of gold atoms (atomic number or $Z = 79$). It was also established that the positrons predominantly receive low kinetic energies, generally around 270 keV.

There is a great probability that both the GSI measurements and those done by our group at the University of Kiel are based on the same effect. If one conceives of the impact of a uranium nucleus (atomic number = 92) of 6 MeV energy per nucle-

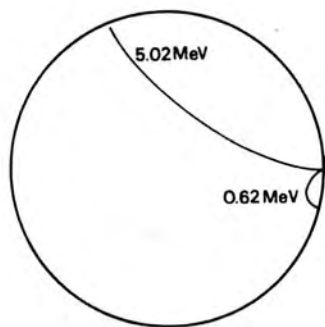

TRAJECTORIES OF AN ELECTRON-POSITRON PAIR

In this photograph of one of Bagge's experiments in a Wilson cloud chamber, the electron exits upward, with energy of 5.02 MeV, while the positron exits downward with energy of 0.62 MeV. According to the Bethe-Heitler theory, the two energies were supposed to be nearly equal.

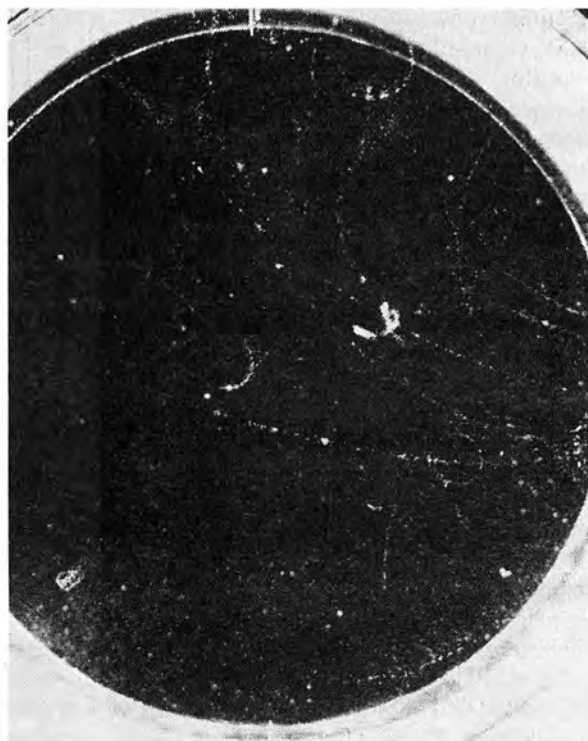

on on another uranium nucleus of the same type at rest as being a pair-producing process, as if the Fourier-analyzed Coulomb fields of the 92 impacting protons would be fields of light quanta, then these trigger electron-positron pairs in the Coulomb field of the nucleus at rest. In these pairs—in accordance with our observations and their consequent interpretations—mainly positrons are created, densely compacted at the surface of the Dirac Sea; that is, with practically zero energy. These positrons are then discharged through the Coulomb field of the uranium nucleus at rest.

Since the positrons must be looked at as wave packets of minimal extension h/mc , they can, by means of this discharge process, gain the energy:

$$E_{kin}^+ = (Ze^2/\hbar c)mc^2 = 92/137 mc^2 = 343.2 \text{ keV.}$$

This is just about the energy found at GSI in the maximum intensity peaks, during six experiments using various actinic impact partners. The results of the experiments our group conducted at Kiel show the same interpretation in the case of the gold nucleus, with somewhat smaller average energies:

$$E_{kin}^+ (\text{Kiel}) = E_{kin}^+ (\text{GSI}) \cdot 79/92 = 294.7 \text{ keV.}$$

Notes

1. "Puzzling Positron Peaks Appear in Heavy Ion Collisions at GSI," by Bertram Schwarzschild, *Physics Today*, Nov. 1985, p. 17.
2. Erich R. Bagge, *Fusion* (German-language edition), Dec. 1985, p. 11; and *International Journal of Fusion Energy*, Jan. 1985, p. 53; Ahmed Abu El-Ela, Soad Hassan, Erich R. Bagge, *Atomkernenergie/Kerntechnik*, Vol. 47, No. 109, 1985; Vol. 45, No. 208, 1984; *Fusion*, Nov.-Dec. 1985, p. 29.

Prof. Bagge's 'Geometric Nucleus'

This memo was written by Ralf Schauerhammer, an editor of the German-language Fusion magazine, March 12, 1988.

Some weeks ago, I explained the key features of Dr. Moon's "Kepler" nucleus to Prof. Erich Bagge. Although he had doubts about some of the specifics of the construction, he immediately agreed to the basic conception and stated that he is convinced that the atomic nucleus can only be understood "geometrically," and that the "formal" description prevalent today does not explain much. He told me that he had already, 40 years ago, developed a geometric concept of the nucleus.

When Bagge read the paper of Mrs. Goeppert-Mayer on the empirical results of the "magic numbers," he thought that there must be a geometrical explanation for these numbers. He remembers still today, how he got the crucial idea in January 1949, while shaving one morning. (His basic concept is published in *Naturwissenschaften*, Jahrg. 38, S. 473 ff.)

There are two rows of "magic numbers": 2, 6, 14, 28, 50, 82, 126; and 2, 8, 20, 40, 70, 112. They result from the formula:

$$N(N) = \frac{N^3 + 5N}{3}, N = 1, \dots, 7$$

$$G(N) = \frac{N^3 - N}{3}, N = 2, \dots, 7.$$

The series of "magic numbers" usually used is a combination of both; that is, $G(2) = 2$, $G(3) = 8$, $G(4) = 20$, $N(4) = 28$, $N(5) = 50$, $N(6) = 82$, $N(7) = 126$. The "break," which is responsible for the shift from one series to the other, is usually explained theoretically as a result of the spin-orbital-force between nucleons. Dr. Bagge considers these forces unnecessary and conceptually contradictory.

What is important about these formulae is that they reflect a three-dimensional geometrical structure,



Stuart Lewis/EIRNS

German nuclear pioneer Erich Bagge (left) and Robert Moon in 1985, in a discussion of the history of nuclear energy, sponsored by the Fusion Energy Foundation. Bagge's unique interpretation of the Darmstadt heavy ion collision experiments was one input into Moon's conception of nuclear structure.

which Bagge later explained by "minimal close packings of regular geometric objects." A student of his did experiments by packing regular geometric bodies in a rubberskin, and reproduced exactly the series of the "magic numbers" when he used ellipsoids.

A two-dimensional example can be constructed with coins and a rubberband. You get 1 for the first "two-dimensional magic number" and 7 for the second one, because 6 fit around the one in the middle, and so on.

I have to take a close look at this work. I believe what Dr. Bagge did, is an application of a three-dimensional "isoperimetric principle" applied to ellipsoids. The "empirical" reason Dr. Bagge gave for the use of ellipsoids is the predominant occurrence of even numbers in nucleons. A deeper reason, however, might be found viewing the process of nucleus-formation from the standpoint of conical functions and their elliptical integrals.

The history of Dr. Bagge's discovery is noteworthy. Immediately after he

got the idea, he explained it to Drs. Suess and Jensen, who had passed by on a trip from Copenhagen to Göttingen. They had not worked on the structure of the nucleus previously, but took Bagge's idea and reformulated it in an algebraic version. Then they published it in that form without mentioning Bagge at all!

Priority Veiled

The referee of the journal *Naturwissenschaften*, (Haxel) delayed Bagge's note on the subject long enough so that it was published only in the same issue with the article of Jensen and Suess, to veil Bagge's priority. Then Jensen and Suess later got the Nobel Prize for discovering the so-called "shell structure" of the nucleus. Also, in the *Physical Review*, Bagge's idea was published under a totally different name (Gouldsmith on "Electronspin"), and only after Bagge's intervention was a note introduced stating that Bagge had published the "same idea already two years earlier."

2. Dr. Robert J. Moon: 'Space Must Be Quantized'

Robert J. Moon, professor emeritus at the University of Chicago, discussed the idea that led to his hypothesis of the geometry of the nucleus in an interview published in Executive Intelligence Review, Nov. 6, 1987. These excerpts from his remarks appeared in the May-June 1988 21st Century.

The particular experiment that provided the immediate spark leading to the development of my model of the nucleus was one by Nobel Prize winner Klaus von Klitzing.

Von Klitzing is a German who looked at the conductivity of very thin pieces of semiconductor. A couple of electrodes are placed on it. The electrodes are designed to keep a constant current running through the thin semiconductor strip. A uniform magnetic field is applied perpendicular to the thin strip, cutting across the flow of the electron current in the semiconductor strip. This applied magnetic field, thus, bends the conduction electrons in the semiconductor so that they move toward the side. If the field is of sufficient strength, the electrons become trapped into circular orbits.

This alteration of the paths of the conduction electrons produces what appears to be a charge potential across the strip and perpendicular to the original current flow, producing a resistance. If you measure this new potential as you increase the magnetic field, you find that the horizontal charge potential will rise until a plateau is reached. You can continue to increase the magnetic field without anything happening, within certain boundaries, but then, once the magnetic field is increased beyond a certain value, the potential will begin to rise again until another plateau is reached, where, within certain boundaries, the potential again does not increase

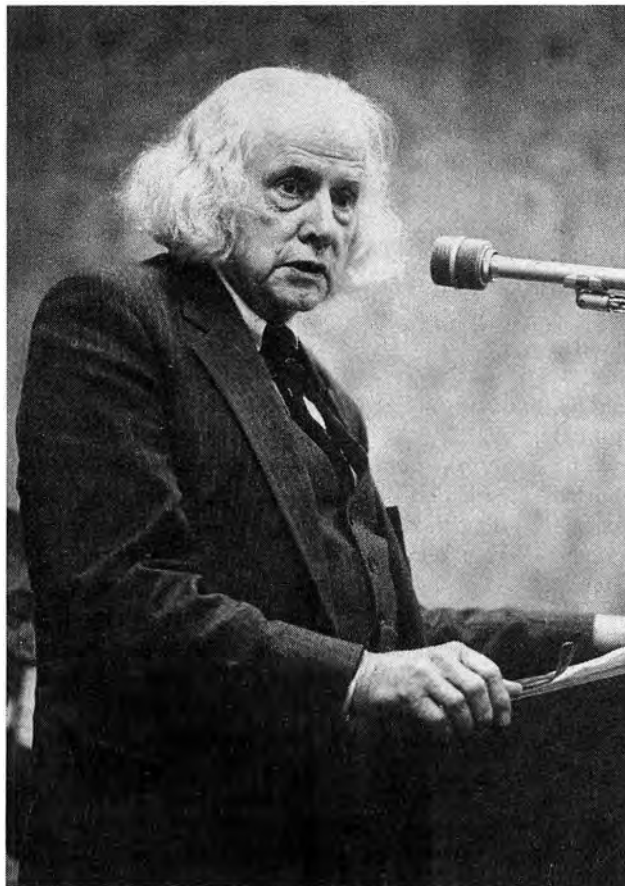

Philip Ulanowsky/EIRNS

Robert J. Moon: "I began to conclude that there must be structure in space, and that space must be quantized."

Just as in the atomic nucleus, only a definite number of rotational states is possible, and only a definite number of electrons can belong to the same state. This rotational state is called the Landau level.

What we have here is a slowly increasing magnetic induction, and resistance increases until plateau values are found. At these values, there is no further drop in voltage over a certain band of increased magnetic induction. Some electrons now appear to travel through the semiconductor as if it were a superconductor.

The question I asked myself was, why at higher field strengths did no more plateaus appear? Why did no higher plateau appear, for example, at 51,625 ohms? At the lower end it was clear what the boundary was—at the

with an increasing magnetic field.

What is being measured is the Hall resistance, the voltage across the current flow, horizontal to the direction of the original current, divided by the original current.

All of this was done by von Klitzing at liquid hydrogen temperatures to keep it cool and prevent the vibration of particles in the semiconductor lattice, a silicon semiconductor. The current was kept constant by the electrodes embedded in it.

Under these special conditions, as the current is plotted as a function of the magnetic field, we find that plateaus emerge. There are five distinct plateaus. At the highest field strength the resistance turns out to be 25,812.815 ohms. As we reduce the field, we find the next plateau at 12,906 ohms, and so on, until after the fifth, the plateaus become less distinct.

The theory is that the strong magnetic field forces the electrons of a two-dimensional electron gas into closed paths.

point at which six pairs of electrons were orbiting together, the electrons would be close-packed, but the magnetic field was too weak to create such a geometry. However, I asked myself what the limit was at the upper end.

This was what led to my model of the structure of the atomic nucleus. I started out by considering that the orbital structure of the electrons would have to account for the occurrence of the plateaus von Klitzing found, and I realized that the electrons had to be spinning together in pairs as well as orbiting. That was the significance of the upper boundary occurring at the value of 25,000-plus ohms.

I first concluded that this happens because the electron has a spin. It spins around its axis and a current is produced by the spin, and the spinning charges produce a little magnet.

According to Ohm's law, the current is equal to the field divided by the resistance, so that the resistance is equal to the field divided by the current. Von Klitzing found that the resistance in the last plateau was 25,812 ohms. I wanted to find out why this was the last distinct plateau.

First of all, I realized that the electrons seem to like each other very well. They travel around in pairs, especially in solid-state materials such as semiconductors. The spins will be in opposite directions, so that the north pole of one will match up with the south pole of the other.

Well, as long as we are limited to a two-dimensional space, then we see that by the time we get six pairs orbiting, we will have close packing. We see a geometry emerging, a structure of the electron flow in the semiconductor.

Now, the Hall resistance is determined by Planck's constant divided by the ratio of the charge squared. But we also find this term in the fine structure constant. Here, however, the Hall resistance must be multiplied by the term $\mu_0 \times c$ (c = the velocity of light); in other words, we must take the ratio of the Hall resistance to the impedance of free space. We can look at this as a ratio of two different kinds of resistance, that within a medium to that within free space itself.

This led me to look for a three-space geometry analogous to that which I had found in the two-dimensional space in which the Hall effect takes place. I began to wonder how many electron pairs could be put together in three-space, and I saw that one might go up to 68 pairs plus a single electron, in order to produce 137, which is the inverse of the fine structure constant.

Well, that's the way ideas begin to grow. Then it becomes very exciting. And then you begin to wonder, why these pairs, and why does this happen?

Space Has a Structure

The velocity of light times the permeability of free space is what we call the impedance of free space. There is something very interesting about the impedance of free space. According to accepted theory, free space is a vacuum. If this is so, how can it exhibit impedance? But it does. The answer, of course, is that there is no such thing as a vacuum, and what we call free space has a structure.

The impedance of free space is called reactive impedance, since we can store energy in it without the energy dissipating. Similarly, radiation will travel through a vacuum without losing energy. Since there is no matter in free space, there is nothing there to dissipate the energy. There is nothing for the radiation to collide with, so to speak, or be absorbed by, so the energy just keeps there. This is what we call the reactive component.

It is "reactive," because it does not dissipate the energy, but is passive. And this equals 376+ ohms. This reactive impedance is one of the important components of the equation of the fine structure constant.

The equations for the fine structure constant will always involve the ratio 1:137, and actually this ratio, as Bohr looked at it, was the ratio of the velocity of the electron in the first Bohr orbit, to the velocity of light. That is, if you multiply the velocity of the electron in the first Bohr orbit of the hydrogen atom by 137, you get the velocity of light.

The orbiting electron is bound to the hydrogen atom around which it is orbiting. This stuck in my mind for several years. Immediately, as you begin looking at this ratio, you see that this is identical with the impedance in a material medium, like the semiconductor von Klitzing experimented with, compared to the permeability of space.

No Empty Space

Since the Hall resistance is dissipative, then we have here a ratio between two different kinds of resistance, a resistance within a material medium and a resistance of "space." That being the case, we are entitled to seek a geometry of space—or in other words, we are no longer able to talk about "empty space." From looking at von Klitzing's experiment, I was led to these new conclusions.

This is the equation for α , the fine structure constant:

$$1/\alpha = 2h/(e^2\mu_0c).$$

Another conclusion I was able to draw, was why the number "2" appears in the fine structure constant. Well, it turns out that the 2 indicates the pairing of the electrons. And when you get this ratio, this turns out to be 1:137. So you have the ratio of the impedance of free space, which is nondissipative, over the impedance in a material media, as measured by von Klitzing, which is dissipative, giving you approximately 1:137. We have seen major advances in semiconductors in recent decades which permit us to make very accurate measurements of the fine structure constant.

Today, we have even better methods based on superconductors. In a superconductor, the impedance will be very low, like that of free space. There is no place for the electron in the superconductor to lose energy.

As a result of this, I began to conclude that there must be structure in space, and that space must be quantized. Of course, I had been thinking about these ideas in a more general way, for a long time, but looking at von Klitzing's work in this way, allowed me to put them together in a new way, and make some new discoveries.

3. Pauling and Others Comment On the Moon Model

We reprint here a few of the responses received to the 1988 article on the Moon Model by Laurence Hecht ("The Geometric Basis for the Periodicity of the Elements," 21st Century, May-June 1988, p. 18). This article, available on the 21st Century website, was the first published elaboration of Robert J. Moon's hypothesis on the structure of the atomic nucleus. These letters and Hecht's replies appeared in the September-October 1988 issue of 21st Century.

Pauling: Does It Match Experimental Data?

To the Editor:

... It seems to me that while Dr. Moon's ideas about the atomic nucleus in relation to the five Platonic solids might have some aesthetic appeal, it is highly unlikely that they have any significant validity. They seem to me to be incompatible with a great amount of experimental information that exists about the properties and structures of atomic nuclei.

... I shall mention one example. There are many experiments, such as the diffraction pattern of high-energy electrons from the nucleus, and the values of the rotational energy levels, that show that lead-208 has essentially a spherical structure in its normal state, and also that the nuclei of radon and protactinium are quite close to spherical. Dr. Moon's structures, shown on page 25, indicate a prolate structure with axial ratio about 2. This is a serious difference with experiment.

Linus Pauling,
Linus Pauling Institute of
Science and Medicine
Palo Alto, Calif. 94306

The Author Replies To Pauling's Criticism

Perhaps truth and beauty can, after



Linus Pauling (1901-1994)

all, be reconciled.

Dr. Moon points out that the data of high-energy electron diffraction pattern scattering must be interpreted very carefully. According to classical physics, the electron, though of slight mass, is in fact a large object when compared to the nucleus—the exact size depending on various assumptions, including a spherical shape and whether the charge is distributed throughout the whole volume or the shell only. On acceleration, the additional problem presents itself that most of the charge appears, to the slower moving observer, to be flattened out into the shape of a disk.

While a "point" electron could distinguish the finer aspects of shape in the nucleus, we have no justification for assuming that that is its shape. Indeed, just what an electron looks like is among the most speculative and controversial matters in modern science. (For example, see W.H. Bostick, "The Morphology of the Electron," in the *International Journal of Fusion Energy*, Jan. 1985, p. 9.) But assuming an electron somewhat larger than the "ideal point," we see that there are two interpretations that could

be given to the appearance of sphericity in the data. A large electron would be unable to distinguish the dumbbell-like shape of two dodecahedra from two spheres, especially where a large number of atoms is being examined.

In that case, the apparent sphericity of 82-lead-208, 86-radon, and 91-protactinium is just as we should expect from Moon's nuclear model: Protactinium is two complete dodecahedra, joined at a single vertex. Radon is two dodecahedra joined at a face. Lead-208 (the most abundant isotope) is one complete dodecahedron and a complete icosahedron, surrounded by a very stable dodecahedral configuration with 16 of the 20 vertices filled.

—Laurence Hecht

Usefulness Questioned

To the Editor:

I do not think that the hypothesis on the structure of the elements is useful. There have been many such attempts before, and complete books have been devoted to listing them. We just have to accept that the microworld in which quantum mechanics operates is different from the world of the scale of our everyday lives.

Similarly, the world on a cosmological scale is again different. Just as man made God in his own image so there is tremendous pressure to make everything else anthropocentrically and it is not necessarily so. I would recommend the textbook *Lectures on Physics* by Richard Feynman as a more reliable guide.

The deficiencies of adequate scientific education at an elementary school level cannot readily be remedied by popular magazines. Look at the state of education in the White House!

Professor Alan L. Mackay,
Department of Crystallography
Birkbeck College
University of London



Stuart Lewis/EIRNS

Friedwardt Winterberg in June 1985, at a memorial conference for space scientist Krafft Ehrlicke.

Does the Nucleus Have Crystal-like Properties?

To the Editor:

The article on the geometric structure of the nucleus is indeed very interesting. It all boils down to the question, does the nucleus (to some extent) have crystal-like properties.

In fact, very recently two other scientists, Cook and Dallacasa, have posed the same question (see "Face-centered-cubic Solid-phase Theory of the Nucleus," *Physical Review C*, Vol. 35, No. 5, May 1987, and "A Crystal Clear View of the Nucleus," *New Scientist*, March 31, 1988).

However, because both the liquid drop and shell models of the nucleus are quite successful as well, these models cannot

be suddenly altogether wrong. It may be, as it has been in other areas of science before, that the truth is somewhere in between. The nucleus is almost certainly superfluid, exhibiting a large energy gap, and it may perhaps be a superfluid liquid crystal.

The theory of liquid crystals was pioneered by the Soviet physicist J. Frenkel, but I could not find any reference in his work on superfluid liquid crystals. Only [Richard] Feynman did something along these lines to explain the rotons in superfluid helium predicted by [the Soviet physicist L.D.] Landau.

Dr. Friedwardt Winterberg
Desert Research Institute
University of Nevada

Dr. Moon's Comments on Linus Pauling's Criticism

A summary by Laurence Hecht of a telephone discussion with Dr. Moon on Linus Pauling's criticism of the Nuclear Model, June 8, 1988.

If Linus examines it further, he'll see that the dumbbell shape does not contradict the experimental data. There are two interpretations of the diffraction patterns you can expect from high-energy electrons. Since you are dealing with a large number of atoms and since they are oriented and lined up, it is hard to distinguish a dumbbell from two spheres.

You have the problem: How does a big electron tell you about something so small, in comparison, as a nucleus. The energy of the electron, according to classical theory, is supposed to be added in the form of a ring. If accelerated in an electric field, it polarizes and lines up with the field. Accelerate a spherical electron, which has an electric field in all directions outward from the sphere, and you get a magnetic field perpendicular to the electric field. On acceleration, it flattens out so most of the charge is in the shape of a disk. Most things under high energy do this.

A point electron could distinguish

MOON'S CORRECTION OF THE RUTHERFORD ATOM

The diagram depicts an alpha particle (double positively charged helium nucleus) sharply deflected, along the path from a' to e', by the positively charged nuclear core. In Rutherford's classic experiment of 1910, alpha particles were aimed through a sheet of metallic foil and detected on a screen placed normal to the path. From the measured angular deflection of the particles, conclusions could be deduced about the nucleus. However, Rutherford assumed that no effect resulted from the relative velocity and acceleration of the charged particles. Moon's calculations

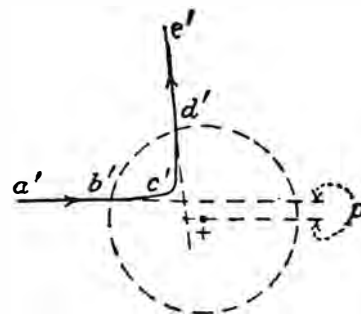

Source: Richtmyer and Kennard, *Introduction to Modern Physics* (New York: McGraw-Hill, 1947)

taking this into account, showed a much closer approach to the nucleus.

the finer points of shape in the nucleus, but not a fast one. The question is, how does the shape of an electron appear to an object it is approaching at near the speed of light. You [Larry] should look up how this is regarded in quantum mechanics in regard to the electric and magnetic dipole moments—particularly, is the magnetic dipole a thin disk?

You can also look at the scattering of neutrons. Rutherford did this, but

using only classical mechanics without the acceleration term from Weber. When [Dr. Moon] took into account the acceleration term, [he] found a very different size for the nucleus than is commonly accepted. Rutherford's paper on the "Distance of the Closest Approach" has never been corrected for this. (Cf. p. 41.)

You thus get something very fundamental here which could open up a lot of important things.

4. The Gifts of Louis de Broglie To Science

by Robert J. Moon

A review of Quantum, Space and Time—The Quest Continues,¹ Part I, 14 essays prepared in honor of de Broglie's 90th birthday anniversary (Aug. 15, 1982) by 18 well-known scientists. This review first appeared in the International Journal of Fusion Energy, Vol. 3, No. 2 (April 1985).

These studies and essays yield a wealth of insight, not only into the way scientists think, and much of the historical aspect of the development of scientific thought, but more important, into the conception of ideas from the spirit within a scientist. This always takes poetic form, with many facets that yield entrées into a more perfect description of God's creation. Indeed de Broglie described his discovery of wave mechanics in this way: "A great light suddenly appeared in my mind."

Ideas are buried within the individual's spirit and burst forth when the individual's freedom is not suppressed by worldly materialism and dogmatism. Ideas do not come from conscious mentation or reading, since ideas are part of the individual's spiritual makeup and must be searched for from within in order to be discovered. Ideas may flow contrary to the prevailing stream of human thought. The individual will most likely have to navigate upstream and avoid aimless drift, in order to find fertile soil in which to plant an idea for the benefit of mankind.

Such a navigator was de Broglie. Kind and gentle to all, but firm with his concepts, he "attempted to develop the most promising alternative to the orthodox version of quantum mechanics." He started with a model that involved a pilot wave or guiding wave vibrating within a particle, much like a radar on an airplane sees the entire topology ahead, and this in turn guides the plane by means of actions by the pilot. This pilot wave calls for a double solution to the equations of quantum mechanics.

De Broglie was pounced upon by members of the Fifth Solvay Physics Conference in 1927. The Congress did not like his concept of the pilot wave associated with a particle and the consequent double solution. Wolfgang Pauli made important objections to de Broglie's concept and felt that it did not provide a consistent account of the many-body system or, in par-



Louis de Broglie (1892-1987)

ticular, a two-body scattering process. De Broglie felt that his idea had at least a germ of an answer. This was not appreciated by those present at the Solvay Conference, and de Broglie's friend Einstein did not speak up for the theory. These two rejections led to rejection by the Congress, which in turn caused de Broglie to close his books on this theory, giving up further work on it.

Einstein had in fact written to H.A. Lorentz on Dec. 16, 1924:

A younger brother of de Broglie (the one we know) has undertaken a very interesting investigation (Paris Dissertation, 1924) to interpret Bohr-Sommerfeld quantum rules. I believe this is a first weak ray to illuminate this most serious of our physical riddles. I have also found something that speaks for his construction. (p. 41)

De Broglie learned of the letter only after Einstein's death in 1955.

In the introductory paper titled "Louis de Broglie—Physicist and Thinker," Jean-Pierre Vigié opens with a statement very characteristic of de Broglie, "Great physicists fight great battles." These essays, Vigié says, underline "his present position as forerunner, inspirer, and leader of a trend of research which is rooted in his dissent with the overwhelming majority of theoretical physicists—and his solidarity with Einstein in the famous Bohr-Einstein controversy." His scientific observations and interpretations opened new areas particularly on the "meaning and value of scientific knowledge itself."

There are four essential groups of problems with which these essays are concerned and in which de Broglie fought great battles.

(1) The first set is concerned with Heisenberg's dictum that microphenomena exist if and only if they are observable. De Broglie, on the contrary, held to his concept of the pilot wave, Ψ —a real microphenomenon wave that guided particles.

(2) The second set of problems has to do with Bohr's concept that quantum probabilities represent an ultimate limit to human knowledge. Contrary to this, de Broglie conceived of a random set of subquantal hidden variables in a real vacuum with which particles interact and exchange energy; that is, a vacuum alive with subquantal distributions of violent motions,

so that particle energy changes when moving from one point to another, in accordance with the principle of least action. These new quantum forces reflect the “wholeness” of the surrounding universe. This concept is that of a new ether model. The vacuum state is the state of “empty space,” vibrant with a covariant distribution of covariant spinning oscillators and with random jumps in the velocity of light. This ether is not the old ether-at-rest model, but is a “new description of nature’s ‘vacuum’ that implies a Copernican revolution against the world vision of Newton and Laplace, since it organically combines causal motions with permanent randomness. It interprets quantum mechanics as a Markov process at the velocity of light,” Vigier writes.

(3) The third set concerns “the physical origin of the laws of nature themselves.” The Copenhagen School, according to Vigier, “regards Quantum Theory as a general form of knowledge that is final in its essence. If this is true, knowledge of nature will never change again but only eventually develop through the introduction of new elementary particles, new Lagrangians, new quantum numbers, and new forms of interaction.”

De Broglie and Einstein’s approach to theory is basically different, Vigier says. Reality is immense, and no description of the universe by means of a theory and experimental proof will ever be a total and final one. Rather, each new theory proved by experiment is just another thin layer of insight into the nature of the real world.

(4) The fourth set of problems deals with “the existence of causality in nature and covers the present controversy raised by the, now very probable, confirmation of the nonlocal character of quantum mechanical predictions, discovered by John Bell in the Einstein-Podolsky-Rosen type of experiment.”

Bohm Rediscovered the Pilot Wave

John S. Bell’s contribution, “On the Impossible Pilot Wave,” attempts to present the essential idea “so compactly, so lucidly, that even some of those who know they will dislike it may go on reading....” Referring to the von Neumann impossibility proof, Bell “saw the impossible done” in David Bohm’s papers (1952, 1952a) demonstrating “how parameters could indeed be introduced into nonrelativistic wave mechanics, with the help of which the indeterministic description could be transformed into a deterministic one.” The pilot wave, ignored by Born and von Neumann, was not impossible. David Bohm had rediscovered the pilot wave!

Bell sets up a simple model of a system whose wave function is $\Psi(a, x, t)$ with one discrete argument, $a = 1, 2 \dots N$, one continuous argument, x , of position, where $-\infty < x < +\infty$ as well as a continuous argument of time, t .

He then considers a particle with an “intrinsic spin” free to move in one dimension, and finds a solution of the Schrödinger equation that yields various wave packets Φ that “move apart from one another, and after a sufficiently long time, . . . overlap very little.” This model is similar to that of a Stern-Gerlach experiment.

Then, by means of the ideas of de Broglie and Bohm, Bell adds to the wave function, Ψ a particle position, $X(t)$. A particle always has a definite position, and the time evolution of the particle position after many repetitions of the experiment

yields a probability distribution of $p(X(t), t) dX(t)$, which is the conventional quantum distribution for position. Thus the conventional predictions for the result of the Stern-Gerlach experiment obtain. The result is a position observation. Bell writes, “probability enters once only, in connection with initial conditions. . . . Thereafter the joint evolution of Ψ and X is perfectly deterministic.” Thus in accordance with Bohr, the results are products of the complete experimental set-up, “system” plus experimental “apparatus” and are not to be regarded as “measurements” of preexisting properties of the “system” alone.

Bell concludes with these precepts so clearly emphasized in the de Broglie-Bohm picture:

- (1) “Always test your reasoning against simple models.”
- (2) The only observations that must be considered in physics are position observations.
- (3) In using the word “measurement” it is easy to expect that “‘the results of measurement’ should obey some simple logic in which the apparatus is not mentioned.” “System and apparatus” are inseparable in probing the nature of God’s creation. Bell favors banning the word “measurement” in favor of “experiment.”

In order to best understand how an idea of de Broglie’s had been shelved in 1927, forgotten, and then rediscovered by David Bohm in 1951, Bohm’s own testimony of the sequence of events is most apropos. It is reproduced here in full, for it has many facets that should help any physicist to go forward in spite of the many vicissitudes that may intervene.

David Bohm is quoted (pp. 90-91) as follows:

I wrote a book from Bohr’s point of view, mainly in order to understand the quantum theory. But after I had written the book, I felt that I still didn’t really understand the quantum theory, and so I began to look for new approaches. Meanwhile, I had sent copies of the book to Bohr, Pauli, Einstein, and other scientists. Bohr did not respond, but Pauli sent an enthusiastic reply, saying he liked the book very much. Einstein also got in touch with me, saying that though the book explained the quantum theory about as well as would ever be possible, he still was not convinced but wanted to discuss the subject with me.

We had several discussions, the net result of which was that I was considerably strengthened in my feeling that there was something fundamental that was missing in quantum theory. This may perhaps have made me work with greater energy, but Y. Ne’eman’s statement that I was “shaken” by my conversation with Einstein and “had not recovered to this day” is entirely false. In any case, what actually happened was that I soon came upon the trajectories-interpretation, and prepared a preprint, copies of which were sent to many physicists including de Broglie, Pauli, and Einstein. I learnt shortly thereafter from de Broglie that he had developed this idea much earlier and so, in later versions of the paper, I acknowledged this fact. Pauli was very negative in reply, saying also that de Broglie had developed the same model many years earlier, and that it had been shown by him to be wrong at the Solvay Congress.

As a result of Pauli's letter, I developed a theory of the many-body problem answering his objections, which was incorporated in a second paper [(1952) *Phys. Rev.* **85**: 180]. I had several further discussions with Einstein, but he was not at all enthusiastic about the idea, probably mainly because of the feature of nonlocality of the quantum potential, which conflicted with his basic notion that connections had to be universally in the fundamental laws of physics.

While I can understand Einstein's objections fully, I feel that it may have been a tactical error on his part to dismiss such ideas because they conflicted with his own notions as to the nature of reality. For though perhaps unsatisfactory in many respects, they made possible, as explained in the present paper [by Bohm and B.J. Hiley, pp. 77-92 of the work reviewed here; see below] certain important insights into the meaning of the quantum theory. I feel that a correct approach might have been to encourage such work as a purely provisional approach, but recognizing that it was not likely in itself to be a fundamental theory, without further radically new ideas. The result of not doing this sort of thing was that, for the most part, fundamental physics was reduced to its present state of relying almost exclusively on formulae and recipes constituting algorithms for the prediction of experimental results, with only the vaguest notions of what these algorithms might mean physically.

Bohm and B.J. Hiley ("The de Broglie Pilot Wave Theory and the Further Development of New Insights Arising Out of It") discuss de Broglie's approach in which he assumed a double-solution model to quantum mechanics. That is, (1) a real physical wave which satisfied Schrödinger's equation, (2) a particle following a well-defined trajectory, (3) the momentum, \mathbf{p} , of this particle was related to the wave through the equation:

$$\mathbf{p} = \hbar \nabla \phi \quad (1)$$

where ϕ is the phase of the wave function. The particle is being guided by the wave ("pilot wave"). (4) Inside the particle there is a periodic process (a "clock") which, when at rest has a frequency $\omega_0 = m_0 c^2 / \hbar$, and the condition for the clock to stay in phase with the pilot wave was derived to be

$$\oint \mathbf{p} \cdot d\mathbf{x} = nh.$$

(5) The locking in phase, he suggested, is a nonlinear interaction, which is crucial in order to obey Schrödinger's equation, and this double solution described the guidance condition. De Broglie's model "provides at least a conceptual connection between quantum mechanics and Einstein's attempt at a unified field theory, in which the particle is also treated as a nonlinear singularity that merges with the background field."

Members of the Fifth Solvay Congress in 1927 objected to this idea, in particular Pauli, and not even Einstein spoke up for the theory. Twenty-five years after de Broglie cast the idea aside, David Bohm rediscovered the "double solution" with its pilot wave and showed it to be a consistent account of a one-body system. In a second paper he extended it to a many-body system in answer to Pauli's objection and this led to new

insights as to the meaning of quantum mechanics. Bohm's exchange of ideas with de Broglie led the latter—then 60 years of age—to again take up his old ideas after 25 years, although his approach is not accepted by most physicists.

The Trajectory Interpretation

Bohm and Hiley develop the trajectory interpretation for a many-body system as an extension of de Broglie's ideas. Their contribution here (pp. 80-87) is so significant that it merits a detailed account. They start with the N -body wave function as

$$\Psi(\mathbf{x}_1 \dots \mathbf{x}_n) = R(\mathbf{x}_1 \dots \mathbf{x}_n) \exp[iS(\mathbf{s}_1 \dots \mathbf{s}_n)/\hbar]$$

and define the momentum of the n th particle (as did de Broglie) as:

$$\mathbf{p}_n = \nabla_n S \quad (2)$$

Equation (2) is substituted into the many-body Schrödinger equation which yields the conservation equation in configuration space:

$$\partial P / \partial t + \sum_n \nabla_n \cdot (P \nabla_n S) / m = 0 \quad (3)$$

(where $P = \Psi^* \Psi$, the probability density in this space), and the modified Hamilton-Jacobi equation

$$\partial S / \partial t + \sum (\nabla_n S)^2 / 2m + V(\mathbf{x}_1 \dots \mathbf{x}_n) + {}^n Q(\mathbf{x}_1 \dots \mathbf{x}_n) = 0. \quad (4)$$

They conclude from this that "each particle will be acted on, not only by the classical potential, V , but also by the *additional quantum potential* Q " (emphasis added):

$$Q = (-\hbar^2 / 2m) \sum_n [(\nabla_n^2 R) / R]. \quad (5)$$

This interpretation shows that new features of quantum mechanics arise basically from the quantum potential Q .

As an illustrative example they consider the case of a two-body system with a product wave function:

$$\Psi(\mathbf{x}_1, \mathbf{x}_2) = \phi_A(\mathbf{x}_1) \phi_B(\mathbf{x}_2) \quad (6)$$

where

$$\phi_A(\mathbf{x}) = R_A(\mathbf{x}) e^{iS_A(\mathbf{x})/\hbar} \text{ and } \phi_B(\mathbf{x}) = R_B(\mathbf{x}) e^{iS_B(\mathbf{x})/\hbar}$$

Thus:

$$Q = \frac{-\hbar^2 \nabla_1^2 R_A(\mathbf{x}_1)}{2m R_A(\mathbf{x}_1)} - \frac{\hbar^2 \nabla_2^2 R_B(\mathbf{x}_2)}{2m R_B(\mathbf{x}_2)} \quad (7)$$

The quantum potential, Q , is the sum of two independent functions. If the classical potential, V , is likewise a sum, $V_A(\mathbf{x}_1) + V_B(\mathbf{x}_2)$ then the Hamilton-Jacobi equation reduces to two separate parts:

$$\frac{\partial S_A}{\partial t} + \frac{(\nabla_1 S_A)^2}{2m} + V_A(\mathbf{x}_1) - \frac{\hbar^2 \nabla_1^2 R_A(\mathbf{x}_1)}{2 R_A(\mathbf{x}_1)} = 0 \quad (8)$$

$$\frac{\partial S_B}{\partial t} + \frac{(\nabla_2 S_B)^2}{2m} + V_B(\mathbf{x}_2) - \frac{\hbar^2 \nabla_2^2 R_B(\mathbf{x}_2)}{2 R_B(\mathbf{x}_2)} = 0 \quad (9)$$

The conservation equation also apparently splits into two

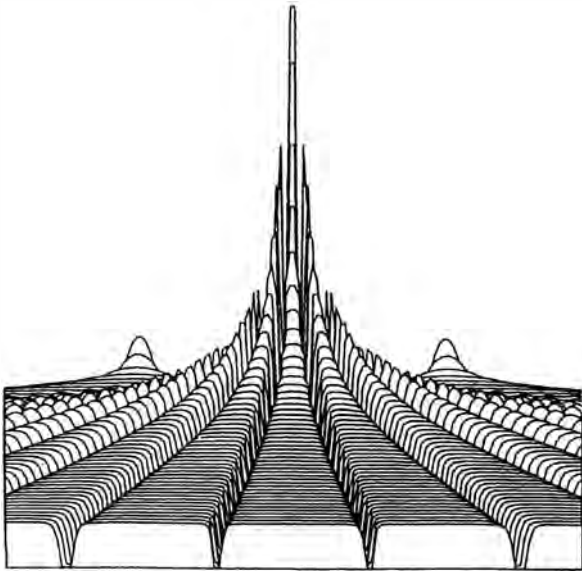

Figure 1
QUANTUM POTENTIAL FOR
A PAIR OF GAUSSIAN SLITS

The slits can be seen in the background. The fringes are formed in the foreground, the dark bands coinciding with the valleys of the quantum potential.

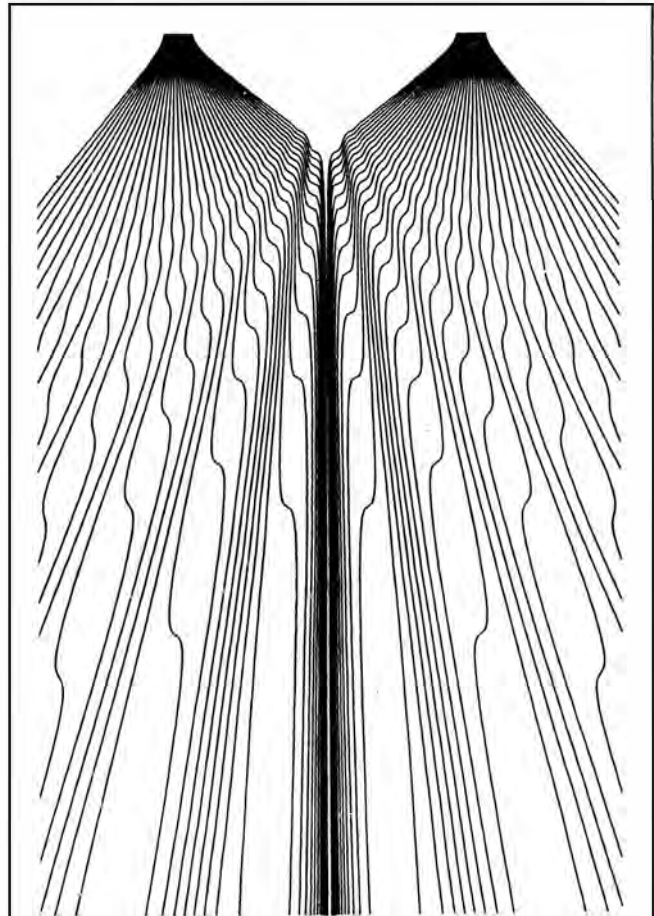

Figure 2

The particle trajectories emanating from the Gaussian slits at the bottom of the figure. The fringes at the top result from the bunching of the trajectories.

independent parts.

Bohm and Hiley note that "the one-body equation (as treated by de Broglie) arises as an abstraction and a simplification of that of the two-body system, and eventually of the N -body system. (It is clear moreover that ultimately these N -bodies must be extended to include the whole universe.)"

Note that quantum mechanics and classical mechanics are expressed in terms of the same language.

[T]he quantum potential, Q , is not altered when the wave function is multiplied by a constant, so that it does not fall to zero at long distances, where the wave intensity becomes negligible. However, the classical notion of analyzability of a system into independent parts depends critically on the assumption that whenever the parts are sufficiently far removed from each other, they do not significantly interact. This means that the quantum theory implies a new kind of wholeness, in which the behavior of a particle may depend significantly on distant features of the over-all environment. This dependence produces consequences similar to those implied by Bohr's notion of unanalyzable wholeness, but different in that the universe can be understood as a unique and in principle well defined reality.

To illustrate in more detail what is meant here. . . consider an interference experiment, in which a beam of electrons of definite momentum is sent through a two slit system. In Figure 1, we show the results of a computation of the quantum potential [C. Philippidis,

C. Dewdney, and B.J. Hiley (1979) *Nuovo Cimento* **52B**: 15]; and in Figure 2, we show the trajectories resulting from the potential.

What is especially significant in Figure 1 is that the quantum potential remains large at long distances from the slits, taking the form of a set of valleys and high ridges, which latter gradually flatten out into broad plateaux. In Figure 2, one sees how the trajectories are ultimately bunched into these plateaux by the overall effect of the potential, and that this brings about the interference pattern. (So that, for example, if one of the slits had been closed, the quantum potential would have been a smooth parabolic function, which would produce no pattern of fringes.) The fact that the quantum potential does not in general fall off with the distance is thus what explains interference and diffraction patterns, and this is clearly also what implies the kind of wholeness of particle and environment to which we have referred above.

One may return here to the analogy of the airplane guided by radar waves. Evidently, it is not a case of

mechanical pressure of these waves on the airplane, but rather, the information concerning the whole environment is enfolded by the waves, and carried into each region of space. The airplane thus responds actively to the *form* of the waves, and this *form* is not altered as the intensity falls off with distance. A similar response to the *form* of the quantum potential is seen to be characteristic of the behavior of the electron. This means that in the microworld the concept of active information is relevant (see Bohm and Hiley [(1975) *Found. Phys.* 5: 93] for more detail).

What has been said thus far about the new kind of wholeness implied by the quantum theory for the one-body system is further strengthened by a consideration of the many-body system. For here one finds that when the wave function is no longer separable as a product of functions of the coordinates of each particle, the quantum potential leads to a strong interaction between all particles of the system, that does not in general fall off to zero when the particles are distant from each other. This is evidently an extension of the dependence of the particle on its overall environment that characterizes the one-body system. But in addition, there is a yet more thoroughgoing breakdown of the possibility of analysis, because the force acting on each particle is no longer expressible as a predetermined function of the position of the other particles. Rather, the functional form of the force depends on the whole set of conditions in which the wave function is defined and determined (so that, for example, the form changes whenever this quantum state of the whole changes).

Let us take, as an example, the hypothetical experiment of Einstein, Podolsky, and Rosen [A. Einstein, B. Podolsky, and N. Rosen (1935) *Phys. Rev.* 47: 777]. We consider there the original form of the experiment, in which we start with a quantum state of a two-particle system in which $(x_1 - x_2)$ and $(p_1 + p_2)$ are both determined. This is given by

$$\begin{aligned} \Psi(x_1, x_2) &= f(x_1 - x_2 - a) \\ &= \sum_k C_k \exp[ik(x_1 - x_2 - a)] \end{aligned} \quad (10)$$

where $f(x_1 - x_2 - a)$ is a packet function sharply peaked at $x_1 - x_2 = a$, while C_k is its Fourier coefficient. Evidently, in this state $p_1 + p_2 = 0$ while $x_1 - x_2$ can be made as well defined as we please.

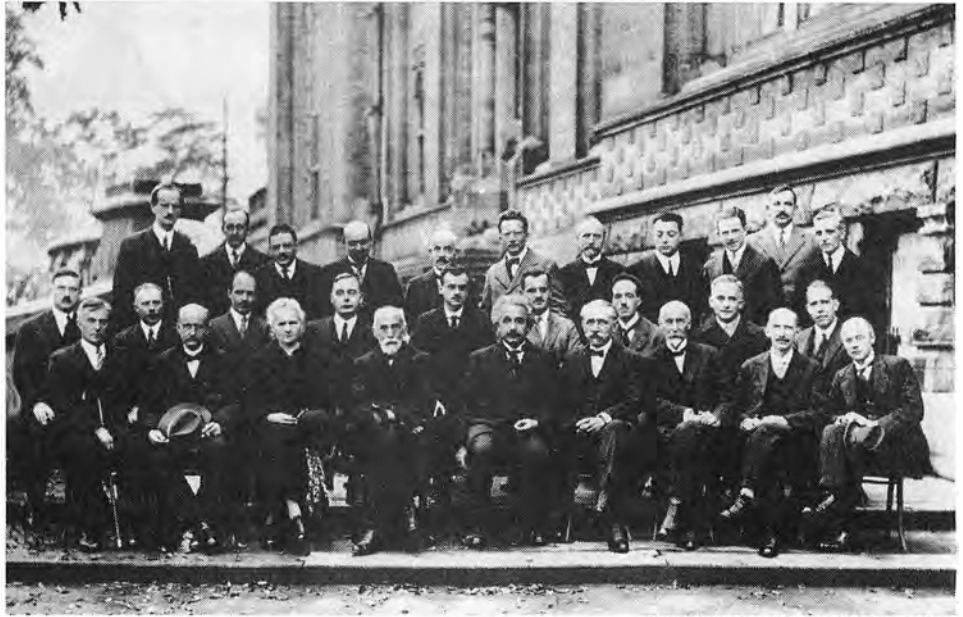

Courtesy AIP Emilio Segré Visual Archives

The Fifth Solvay Physics Conference, held in Brussels, Oct. 23-29, 1927, sponsored by the Solvay International Institute of Physics. Among the 30 scientists who attended the conference were E. Schrödinger, W. Pauli, W. Heisenberg, W.L. Bragg, P.A.M. Dirac, A.H. Compton, L. de Broglie (middle row, third from right), M. Born, N. Bohr (middle row, far right), I. Langmuir, M. Planck, M. Curie, H.A. Lorentz, and A. Einstein.

In this experiment, one can measure x_1 and immediately know that $x_1 - x_2 + a$ (to an arbitrarily high degree of accuracy). Alternatively, we can measure p_1 and immediately know that $p_2 = -p_1$. In both cases, the first particle is disturbed in the process of measurement and, of course, the disturbances can account for the Heisenberg uncertainty relations as applied to the particle $\Delta p_1 \Delta x_1 \geq h$. But since the second particle is assumed not to interact with the first in any way at all, it follows that we are able to find its properties without its having undergone any disturbance whatsoever. Nevertheless, according to the quantum theory, the uncertainty principle, $\Delta p_2 \Delta x_2 \geq h$, must still apply. So Heisenberg's explanation of this uncertainty as due to a disturbance resulting from measurement can no longer be used. It was this which indeed led Einstein, Podolsky, and Rosen [1935] to argue that since both x_2 and p_2 were in principle measurable to arbitrary accuracy without a disturbance, they must have already existed independently in particle 2 as "elements" of reality with well-defined values before the measurement took place. And so, they concluded that quantum mechanics is an abstraction giving only an incomplete and fragmentary description of the underlying reality (as insurance statistics are abstractions that similarly yield an incomplete and fragmentary description of the people to whom they are applied).

As is well known, Bohr [N. Bohr (1935) *Phys. Rev.* 48: 696] answered this argument by means of a further development of his notion that the measurement process is an unanalyzable whole, which led in this case to the conclusion that there is no meaning to the attempt to give a detailed description of how correlations of position and

momentum are carried along by the movements of the parts of a many-body system. It is interesting, however, to go carefully into how the trajectory interpretation differs from that of Bohr, and yet comes to a similar notion of unanalyzable wholeness, though, of course, in another way. For this case, writing $f = Re^{iS/\hbar}$, we obtain for the quantum potential

$$Q = \frac{-\hbar^2}{2m} \left(\frac{\partial^2 R}{\partial x_1^2} + \frac{\partial^2 R}{\partial x_2^2} \right) / R$$

$$= \frac{-\hbar^2}{m} \frac{\partial^2 R}{\partial \Delta x^2} (\Delta x - a) / R(\Delta x - a) \quad (11)$$

with $\Delta x = x_1 - x_2$. This function evidently remains large, even when the distance, a , separating the particles is not small. Therefore, when the properties of the first particle are measured, the quantum potential brings about a corresponding disturbance of the second particle. And from this, it can be shown [D. Bohm (1952) *Phys. Rev.* **85**: 180] that in a statistical ensemble of similar measurements, Heisenberg's uncertainty solutions, $\Delta p_2 \Delta x_2 \geq \hbar$ will still be obtained.

Karl Popper on Bohr and de Broglie

"The new gospel of irrationality," Karl Popper writes, "was first publicly preached by Bohr in Como at the International Congress of Physics 1927; and a few weeks later, in Brussels, at the [Fifth] Solvay Congress." Popper's contribution is "A Critical Note on the Greatest Days of Quantum Theory." He reports young physicists thinking Einstein had become prematurely old at the age of 48! Bohr became the favorite of the young brilliant physicists led by Heisenberg, Pauli, and Max Born into what the young considered a greater revolution than Relativity. Some thought Einstein an antediluvian. Popper thinks "the real break was . . . between a radical and dogmatic empiricism . . . and a critical realism." This empiricism was hidden under the "general usage of the almost incredible term 'observable.' . . . *There are, in fact, no observables in atomic physics.*" There are only indirect observations, that is, traces of the effects of particles on the environment through which the particles pass.

The de Broglie waves made Bohr's atom understandable. The advent of recording Geiger counters and photographic Wilson cloud chambers began the death of the "observer."

A new term, "hidden variable," arose to offset "observable," Popper writes. "In fact . . . all physical 'variables' are hidden." Hidden variables are a consequence of Heisenberg's interpretation of his indeterminacy formulae.

The Copenhagen school interprets Heisenberg's indeterminacy principle as *excluding*:

(a) all measurements which would be better than the product of the change of momentum with the change of position, $\Delta p_x \Delta x \geq \hbar$;

(b) as well as all subjective knowledge better than this; and

(c) the existence of all particles that possess position and momentum to a greater precision than (a).

On the other hand, "a realist interpretation of quantum mechanics would interpret" (a) above "neither speaking about

measurements nor about our knowledge," but rather "as speaking about the preparation of particles, and their position and momenta," independent of whether they are being observed or measured, though the realists recognize that the particles of course will respond to fluctuation in the environment mostly in a partially unpredictable fashion.

Einstein, Podolsky, and Rosen published their famous paper, "Can Quantum Mechanical Description of Physical Reality Be Considered Complete?" in 1935 "to show that a particle possesses both a precise position and a precise momentum." Popper considers the argument valid.

De Broglie on the Poetry of Creativity

Georges Lochak of the Fondation Louis de Broglie ("The Evolution of the Ideas of Louis de Broglie on the Interpretation of Wave Mechanics") writes that de Broglie "always experiences creation as a dazzling poetic vision, and he cannot help feeling sad when he sees it weaken and fade as it is translated by himself or by others into a necessarily mathematical language."

O. Costa de Beauregard ("Reminiscences on My Early Association with Louis de Broglie") tells this related story of de Broglie's appreciation of Paul Valéry: "One spring afternoon, in those days bygone, I went to his [de Broglie's] home in the Paris suburb of Neuilly, with a work on physics I wanted to discuss with him. The weather was beautiful, and the chestnut trees in blossom. I don't remember how it happened that Louis de Broglie came to ask me which was, in my opinion, France's greatest poet. Somewhat hesitatingly, I answered that this was a question of personal taste, and that he might not agree with my choice of Paul Valéry. Well, this choice was also his. His following question was, among Valéry's masterpieces, which one would I select? Again with hesitation, I said that my selection was not the (very rightly) celebrated *Cimetière Marin* but rather the long, superb, philosophical poem with the understated title *Ebauche d'un Serpent* (Sketch on the Theme of a Snake). It is a sparkling theological address of Lucifer to God, starring the Garden, the Snake, Eve, the Tree—and what followed therefrom. Well, again de Broglie agreed. And we spent the rest of the evening reading and commenting on the wonderful poem, which finally has to do with the irresistible growth of knowledge from roots in the darkness beneath, to leaves in the brilliance above.... So it seems to me that there is some Leibnizian preharmony between Valéry and scientists."

As John Bell proclaims, "Long may Louis de Broglie continue to inspire those who suspect that what is proved by impossibility proofs is lack of imagination."

Notes

1. *Quantum, Space and Time—The Quest Continues*, Asim O. Barut et al., eds. (Cambridge: Cambridge University Press, 1984, 680 pp., \$49.50, paperback). The 14 essays in Part I, covering 245 pages, are by the following authors: Jean-Pierre Vigié, Georges Lochak, Alwyn van der Merwe, O. Costa de Beauregard, Karl Popper, J. Andrade e Silva, J.S. Bell, D.J. Bohm and B.J. Hiley, L. de la Peña and A.M. Cetto, Stanley P. Gudder, Ph. Guéret and J.-P. Vigié, Mioara Mugur-Schächter, F. Selleri, and H.-H. v. Borzeszkowski and H.-J. Treder.

Part II is a collection of essays dedicated to Eugene Paul Wigner on the occasion of his 80th birthday, Nov. 17, 1982. Part III, in like manner, is dedicated to Paul Adrien Maurice Dirac on the occasion of his 80th birthday, Aug. 8, 1982.

References

Bohm, D. (1952, 1952a) *Phys. Rev.* **85**: 166 and 180.

5. On the Filamentary Electron, Neutrinos, and Nuclear History

In this 1984 interview, Dr. Robert J. Moon discusses his years on the Manhattan Project, and his five decades of work in frontier areas of nuclear science, with Marjorie Mazel Hecht, managing editor of *Fusion*, the bi-monthly magazine of the Fusion Energy Foundation. Dr. Moon was a founding member of the Fusion Energy Foundation in November 1974. The interview is reprinted from the January-February 1985 issue of *Fusion*.

Question: You've been a member of the Fusion Energy Foundation since its founding 10 years ago in November 1974. What interested you in the FEF?

When I was invited to be one of the founding members, there were essentially four points that attracted me to what the foundation was setting out to accomplish. First, I wanted to bring before the public worldwide the fact that energy is a key ingredient in the well-being of any society and that we had to increase our energy resources in order to expand our populations.

Second, energy from combustion had reached a state of equilibrium; combustion requires oxygen and oxygen comes from plants—leaves, blades of grass, and whatnot—that in the presence of sunlight convert the CO₂ back into oxygen and make chlorophyll in the plants. We had reached an equilibrium there. To continue to use more oxygen for combustion would only do one thing—increase the carbon dioxide content of the atmosphere. And since we need oxygen as human beings, this would suffocate us. It is necessary to develop the more advanced technologies of fission and fusion in order to generate spectral energy beyond that of the Sun that would convert the excess CO₂



EIRNS

Dr. Moon speaking on the need for fusion energy, at the founding meeting of the Fusion Energy Foundation, Nov. 23, 1974.

through photosynthesis into food-producing plants.

Third, we wanted to encourage a greater exchange of ideas on advanced nuclear energy—fission and fusion—among those engaged in research in these fields.

The fourth point, very important, is that we wanted to encourage new ideas and an understanding of phenomena on the frontiers of science, especially fusion energy and related processes.

Question: You are still very much involved in these last two points, since you just began to serve as the editor-in-chief of the *International Journal of Fusion Energy, IJFE*. The journal has set out in an expanded format to aid in the exchange of ideas and new concepts not just in fusion and plasma physics, but also in directed-energy technologies and biophysics. I think you have said that we need a revolution in science today.

Yes. In these times, it is essential that articles in the journal are of such a nature that they bring about the birth of new concepts. That would be very unlikely to occur with the referee system of judging papers for acceptance that is now in use in most scientific journals. The referees always base their reviews on what is known in physics, biology, or biophysics as it stands today; but often there is a greater understanding, new interpretations, new explanations for scientific phenomena that should become known and discussed. It is the IJFE editorial policy to give authors with a new concept a chance to defend their ideas and theses before acceptance for publication. And the journal has expanded to include new areas such as biophysics.

Question: The first issue of the IJFE in its expanded format,

“We’re living in an age in which energy is key. For more people we need more energy. This means controlled fusion. Otherwise we get into a problem; people say, ‘Well, let’s solve it by cutting down the world population.’ But that’s no solution. . . . It means you lose all that creativity.”

—Robert Moon, addressing the founding meeting of the FEF

January 1985, has a few examples of the kinds of articles that are very important and yet did not make it into some of the conventional physics, biology, biophysics, and medical journals. One of the main articles in this issue that makes that point is Winston Bostick's piece on the morphology of the electron.

Yes, I think that Bostick's filamentary model of the electron is an excellent one. Classical physics has made the structure of the electron spherical, that is to say, a rigid, massless sphere covered uniformly with a massless electronic charge, with all the rest mass of the electron generated by the energy contained in the electric field from the surface of the sphere out to infinity. That meant that the electron exists from the surface of the sphere out to infinity! And when in motion, a magnetic field was generated perpendicular to the electric field and the velocity of the electron (these are vector quantities). This additional mass due to the energy of the magnetic field, plus the rest mass, approaches infinity as the velocity of the electron approaches the velocity of light. This model yielded the classical relativistic increase of mass as a function of velocity.

Yet this classical model of the electron was not very congruous with the general nature of things, as something that extended throughout the entire universe; in other words, its mass was not localized.

Winston Bostick describes the electron as right-handed and left-handed screws joined together to make a torus that's been twisted a couple of times and has a charge circulating in it. This filamentary model then produces all the measurable qualities that an electron is supposed to have, and does it in a very amazing way. I think it is a concept that could very well prove useful.

Question: What effect do you think the electron article will have on the physics community?

It's hard to say. Since the state of physics is such that they have gone as far as they can with the classical structure of the electron, the quantum mechanical structure, and the wave mechanical one, I think they really should turn to a structure of the sort that Bostick describes for further insight into the nature of the electron. It seems that Bostick's model describes all known properties of the electron in one model and this concept may possibly lead to the discovery of the yet unknown nature of the electron.

Fundamental Ideas about the Physical World

Question: This is really some of the first material in physics in years, since the era of Heisenberg and Einstein, and so on, that deals with basic ideas about the physical world in a fundamental way.

That's so true. And this kind of thinking has needed to be done. A great deal of the things that are so necessary for science consists of not only looking forward to the future but also referring backwards to what has happened in the past, so as in that

Dr. Winston Bostick demonstrating his filamentary model of the electron at a conference of the Schiller Institute, 1984. At right is Jonathan Tennenbaum. Inset is the contents page from the January 1985 issue of the International Journal of Fusion Energy, which Dr. Moon discusses.

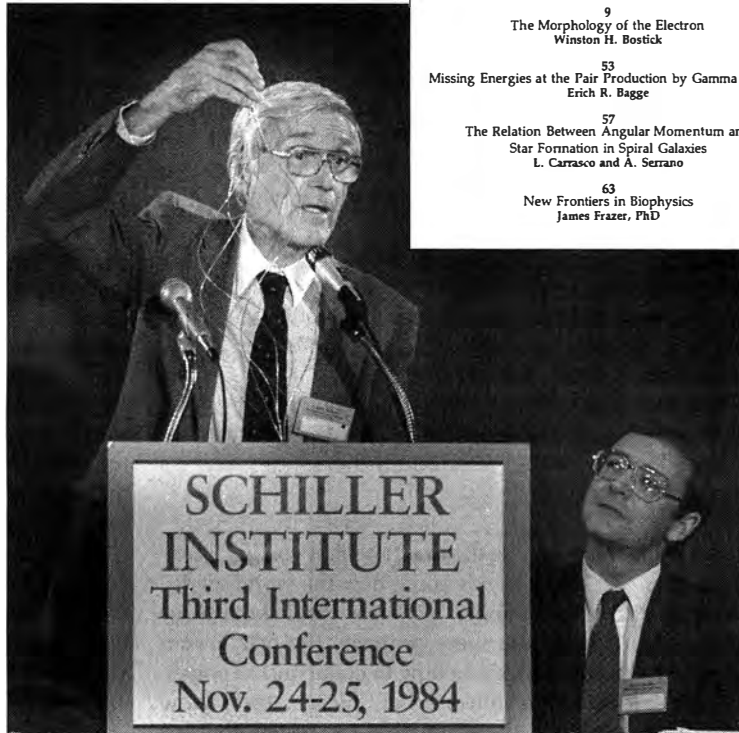

Philip Ulanowsky/EIRNS

International Journal of Fusion Energy	
Vol. 3, No. 1	January 1985
4	Editorial
7	Editor's Note
Articles	
9	The Morphology of the Electron Winston H. Bostick
53	Missing Energies at the Pair Production by Gamma Quanta Erich R. Bagge
57	The Relation Between Angular Momentum and Star Formation in Spiral Galaxies L. Carrasco and A. Serrano
63	New Frontiers in Biophysics James Frazer, PhD

way to get a better idea of the nature of the physical world.

Question: I think that the article by Erich Bagge of Kiel University also fits this description; it contradicts so much of what is going on today in high-energy physics, because he shows clearly that neutrinos do not exist.

That's right. Bagge has shown that neutrinos are not needed in order to describe the beta-ray spectrum and the energy balance in the reactions he studied. To date no free neutrino has been isolated. It's a very small particle, according to the theory, and it has a very tiny cross section of 10^{-44} square centimeters. It's so tiny that it could even pass through the Earth and not be detected!

Question: So as the neutrino is usually described, it's essentially undetectable. I think you mention in your editor's note in the journal that you would need 10^{18} meters of lead to catch even half of the neutrinos postulated.

The only way that scientists have tried to detect it is indirectly; but that is not very satisfactory. They've tried to use the anti-neutrino to detect it, and yet they don't know if the antineutrino exists! The neutrino is still a particle with zero charge in the minds of scientists, but recently it seems to have a slight mass . . . less than 42 electron volts, approximately 1/10,000 times the mass of the electron.

Question: It's like using a ghost to find another ghost—

Or rather, to find an anti-ghost—whatever that is! There are several particles in particle physics, some of which we can describe and for which we have experimental data. For example, the three types of heavy electrons, the various leptons as they are called. Some of these supposedly involve neutrinos in their reactions; but still we have not really found a free neutrino, and we don't have any way to find one, because it doesn't ionize, or react mechanically or electrically with matter.

I think Bagge has shown, that in electron-positron pair production by means of gamma rays, all the energy can be accounted for without the neutrino. This has been the enigma even back in the early 1930s. Where is that missing energy in the beta-ray decay of the nucleus, since all the electrons produced don't come out of the energy of the reaction? The neutrino was invented to take care of that missing energy.

Question: When was the neutrino invented?

It was invented by Pauli in 1927, and then it was elaborated upon by Fermi in 1932. He set up some mathematics that could show some of the properties that a neutrino could have, none of which were measurable. Anyway, this gave most physicists a way to satisfy themselves theoretically that a neutrino must exist, because here there exists a theory that says so. So we have looked for the neutrino all these years and it's never been found free.

Question: I know this won't be the first time that you have contributed to changing men's minds about how the world works. You've accomplished a number of firsts throughout your career. In 1930, I think, you were probably the first person who suggested a doctoral thesis on how to create fusion power, as a graduate student at the University of Chicago. And I know you were the first to build the scanning X-ray system that led to the CAT scanner, the first to discover the correct cathode surface for a high-current electron gun, the first to design and build an effective cyclotron, and a whole host of other things. You were also the editor-in-chief of the first few issues of *The Bulletin of Atomic Scientists*, before it turned antinuclear, so for that reason the present *Bulletin* leaves you out of its history. Would you like to tell us a bit about some of these things?

In my undergraduate work at Southwest Missouri State College, I had two very good professors, one in physics, Prof. A.P. Temple, and another in chemistry, Prof. Robert W. Martin, who allowed me to use all the equipment—including new and unused—that was in the storeroom. I was able to do a lot of fundamental experiments with that. In exchange for this privilege, I had to demonstrate all this before a lot of other classes. At the time I read all the articles describing the possibility of fusion energy, and it seemed to me that this was the energy for the so-called Millennium that was to come, the thousand years of peace and prosperity. Back then, they were talking about its arrival by the end of the century.

Question: This was even before fission was discovered and proved.

Right, it certainly was. And so, when I was just a youngster of 19, I came to the University of Chicago and I presented a proposal on creating fusion energy in the laboratory to the

Physics Department. But they weren't at all interested in nuclear energy. They said the energy is there but it will never come out; all has been done that can be done. As far as they were concerned, the books were closed.

But there was one professor at Chicago, William Draper Harkins, a physical chemist, who had written several papers which I had read on the structure of nuclei, and the particles that should be in the nucleus, and so on. He took me on as a thesis student. "We just have a small amount of equipment for the things you want to do," he said, "but it's very important to construct some of the equipment we don't have in order to do your thesis work." So I went ahead and built the first Geiger counter on the campus. It had a recycling binary recorder that printed out in decimal numbers instead of digital numbers. Also I developed a scale of 10 (a recycling binary), in order to go from the binary system to the decimal system in counting the number of particles out of a radioactive reaction.

While I built the equipment for the nuclear work, I did another thesis on the study of surface structures by means of slow electrons (less than 50 electron volts energy). Then I got involved in building the cyclotron. You know, we built the best cyclotron in the world, right in the middle of the Great Depression! And it cost \$30,000, including my salary and the salary of my associates, as well as the material costs, the model magnets for design of the cyclotron—everything. This model magnet had quite a history. It was borrowed by universities all over the country to help other people build cyclotrons.

We had to make a lot of the equipment ourselves. We designed the transformers and built them, and one of our students helped design the vacuum tubes for the push-pull amplifier of the final stage. These tubes were continuously pumped vacuum tubes with the properly shaped water-cooled grids. These were capable of generating about 100 kilowatts, and it could go up to 200 kilowatts of radio frequency power—10 megacycles—to drive the "dees" of our cyclotron. "Dees" was the name given to the accelerating electrodes, which were like a pill box cut in half, an open "D" shape. So we had a good healthy beam of 150 microamperes of deuterons.

Let me tell you, too, that a man like Fermi didn't get into nuclear physics until the neutron was discovered in 1932. In 1932, people like Fermi came into the field, because here was a particle that could go into the nucleus of the atom; they were bombarding everything, every element, with neutrons. At the time, the most prevalent neutron source was a radium-beryllium source, where alpha particles hit beryllium and the nuclear action that followed produced neutrons. The cyclotron could be used as a prolific source of neutrons.

Historically, it took a long time to discover the neutron—two years after one of the fundamental experiments was done—for them to find out what the particular radiation was that was coming out of the radium-beryllium source. A block of paraffin was bombarded with this radiation and it was discovered that protons were coming out the other side. Well, anyone who's played billiards knows that if a ball is hit head-on by another one of the same mass, it stops and the other billiard ball goes on. Therefore, this strange nonionizing radiation must have had the same mass as the proton, but zero charge. It was knocking the protons out of the paraffin like one billiard ball hitting another one head on.

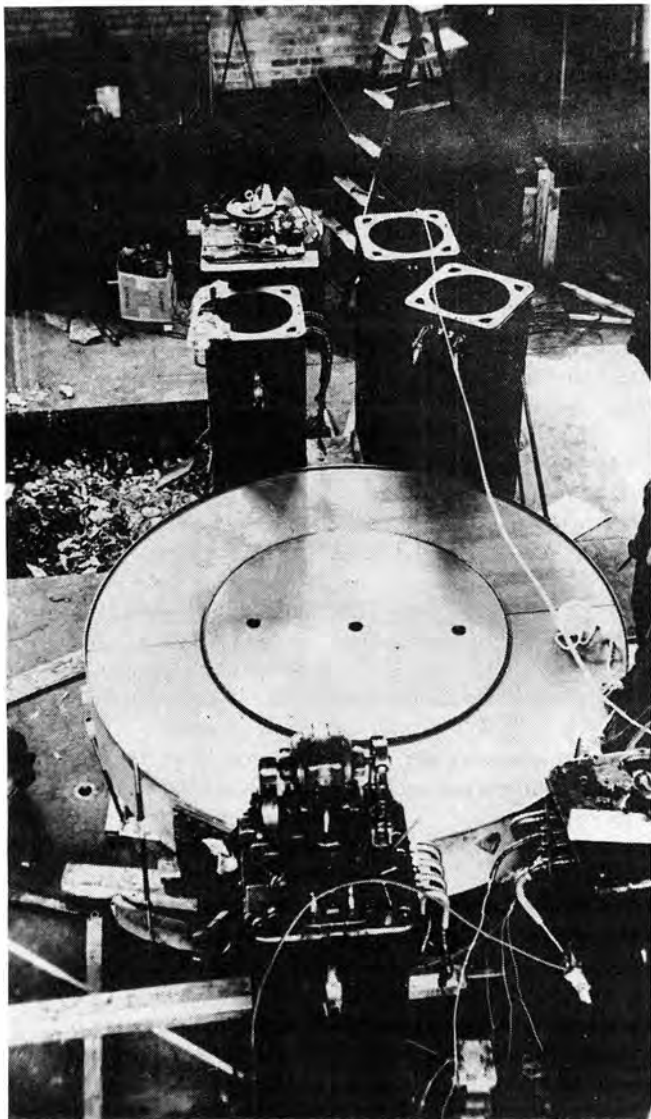

Robert J. Moon

"You know, we built the best cyclotron in the world, right in the middle of the Great Depression!" Here, the core of the cyclotron in assembly.

J. Chadwick, in England, put all of this information together and did some other experiments, and showed that what was coming out—this strange radiation—was a neutron, in fact. That marked a turning point in many physicists' minds, for here was a particle that could enter the nucleus without being repelled by the nuclear charge.

Question: This was in 1932?

Yes. And that was when Fermi entered the field of nuclear physics. Then we went through a period from 1932 to 1938, six years, of just bombarding everything with neutrons, including uranium. And Fermi worked on uranium, and found the products of neutron bombardment were highly radioactive—a neutron was being added to a uranium nucleus followed by one or more electrons being given off. And the same type of nuclear reactions were taking place with the new-product nuclei, and thus

transuranic elements—elements with a greater nuclear charge—were being produced.

Question: Was Fermi working at the University of Chicago at the time?

He was in Italy and he came over to this country to give some summer courses at the University of Chicago, and he had a lot of fun in teaching the courses, particularly in regard to nuclear reactions, with a jovial spirit and frequent use of his pocket slide-rule. Then he would go back to Italy. But as time went on, the Nazi movement and the fascist movement began growing. They always wanted Fermi, who was already very well known, and the King to sit on the stand with Mussolini when he spoke, and Fermi didn't like that. So when things got kind of tough in about 1937, he came over to this country with some of his colleagues and stayed. He joined the University of Chicago faculty, and others from his group went to the University of California. . . .

The Discovery of Fission

Now, the interesting thing was that in these experiments bombarding uranium, there was some fission going on, unknown to Fermi's group, for fission hadn't been discovered yet. Fermi had said, "Oh, we're getting transuranic elements," and he published several papers with that interpretation. He was awarded the Nobel Prize for having done all this wonderful work in discovering "transuranic elements." Well, some of the product nuclei were transuranic, but the majority of product nuclei he was seeing was the result of the fission of uranium, which produces fission products, roughly one-half the mass of uranium, that are highly radioactive. There were many other things for which Fermi could have been awarded the Nobel Prize; however, the Nobel Prize committee happened to choose an erroneous part of his research.

At any rate, the first to know about fission in this country was the Chemistry Department of the University of Chicago. Aristide von Grösse was on our staff, and he had gone over to Germany. He learned of some very significant chemical research. He met with Otto Hahn and Leo Strassman, who were not very well known at the time. They were bombarding uranium with neutrons and studying the chemical properties of what was produced by the bombardment—working on a lab bench about eight feet long. They said to von Grösse: "Look, there are no transuranic elements that we can find. The majority of these elements that are produced from uranium-bombarded neutrons are in the middle of the periodic table. The only thing that we can say about this is that it seems as though the uranium atom is splitting in half!"

And so von Grösse came back with that information, and we had several meetings in the Chemistry Department, particularly among the physical chemists. We couldn't believe it unless we did the experiments, so we did every kind of experiment. Physicists were really slow to pick up on it, because they thought, "Well, all these people in chemistry, they don't know what they're doing!" They said this because what we were finding was contrary to their philosophy.

Anyway, in six months, the world community of scientists realized that uranium did fall apart and it did produce about 250 million electron volts per fission of uranium and about two very high energy neutrons.

6. Cold Fusion Is No Surprise

This interview with Dr. Moon was conducted by Dr. Jonathan Tennenbaum, head of the Fusion Energy Foundation in Europe, after the initial burst of media comment on the announcement of cold fusion by electrochemists Fleischmann and Pons, March 23, 1989. This is the first publication of the interview in English.

Question: We have been talking with a lot of physicists who are all totally astonished at the reports about fusion reactions in palladium. One of them said, "If this is true, I won't go back to my lab, but instead I will apply to become a taxi driver." I have the impression that you are not so surprised, and I would like to know why.

I am not so surprised because the energy [required for the nuclear reaction] divides itself down to where the energy involved is at low temperatures. That means the quanta of energy have been broken up, by means of this process.

Question: So you have a multiphoton process, as is said nowadays.

Right, that's exactly correct. And the mechanism by which it is done is relatively simple, I think. We are not dealing with an infinite vacuum, we are in a well-defined vacuum. Now this is defined, number one, by the great geometrical organization within the nucleus of the palladium. There are no open vertices left [in my model of the nucleus]. If you take one of the models built in plastic and having the regular solids sitting inside each other, and look through it from the side, you will begin to see passage-ways, just like a little tube—not circular, necessarily, but with straight edges. We can have a pentagon or any of those regular polygons that we use in making the nuclear structure.

So if you use palladium, which is one of the means by which you can get this reaction to take place, and if you shoot deuterons in, along the line-up forming these little tunnels, through the nuclei—but we must not forget that this nuclear structure is very much the basis for the extra-nuclear electrons.

Question: I spoke two days ago with a person involved in solid-state physics, working with palladium electrodes. He said, "Well, electron structure has nothing to do with the nucleus. The nucleus is just a charge center." That sounds to me like one of those myths that people pick up in textbooks.

I think so, too. It's a myth all right. The nucleus is the thing that has the structure of the extra-nuclear electrons, the orbits that they have. It determines the energy that is carried in them. And this forms part of the guide into that small part. Beyond each atom, again you have an alignment taking place. So this forms a tube which is quite long—long enough, I would say, to bring about



Philip Ulanowsky/EIRNS

Moon: The palladium forms a waveguide, like a superconductor for electrons. Here, Dr. Moon in 1982, attending a LaRouche conference in New York City.

fusion, with relatively low bits coming out, as the thing took place.

Question: Now, electrolysis with hydrogen and deuterium is nothing new. . . .

That's how we made heavy water, for example.

Question: Why haven't people looked in this direction before?

Well, I think that just as most things are known for a long time: We knew that there was a great energy difference of an alpha particle out of uranium, for example, and other heavy elements, [and also] that with the lighter elements breaking up, as we got into higher and higher energies to produce these elements, they had very short half-lives. So the energy was put into the nucleus, and when it broke up some of that energy was removed. And when you have perfection in palladium, where we are using the Platonic solids with equal faces, the palladium has formed a waveguide.

Similar to a Superconductor

Question: This would be very similar to what's going on in the new superconductors—it is a superconductor.

Right. Oh, absolutely! With the superconductor it is only electrons you are shooting through, not deuterons. If you tried to do the same type of experiments with the magnetic field changed, as we were doing with the superconductors, then this sort of thing would come about. Look at palladium as a superconductor. That would be one of the important things, I think, to establish.

Question: You have said that back in the late 1930s, there was a debate on the future direction of study of the atomic nucleus. One direction you referred to as nuclear physics, the

other as nuclear chemistry.

This is very relevant. We were in the process of building the best cyclotron in the world. We had built the magnet out of the right stuff. The things which entered into this thing were things that were brought about by the physical chemists! At the University of Chicago, William Harkins was one of the outstanding ones. This fact led to the sort of thing which goes on, similar to the chemical reactions between the elements, where you are working only with the extranuclear electrons—they form the chemical elements, and bind the chemical elements together to form a compound.

When we go beyond this, and then we take palladium binding itself together with palladium, you begin to think, well that is 46—you have no vertices unoccupied. And so this allows for the creation of a nice waveguide. The extranuclear electrons say how another palladium atom is going to come next to it, because they are following the structure of the nuclei. And apparently we have a very good alignment, all the way through. Two palladiums come together to form, let's say, palladium two; they begin to build on these flat faces and you get a very long waveguide tube. And, do you know who came to Quebec, and studied the closest approach of alpha particles to the various nuclei?

Question: Rutherford.

Rutherford! You hit the nail on the head. But he made an error in his calculation.

Question: What was that exactly? Was that the famous Rutherford scattering?

That's right. But he has the alpha particle going not so close to the nucleus, because of the wrong force equations. So I recalculated it, based on what we really knew about the force equations, and it turned out that it [the alpha particle] goes much closer; the distance of closest approach was much shorter than Rutherford claimed. So that makes a lot of difference here.

Question: What is the implication of that?

Well, it has the same implication as in the work done in connection with superconductivity. We get into the same field again. Superconductivity means that the particles aren't going to collide with one another, because they have nice little paths to take, which do not call for collisions. In other words, an L-bend would certainly cause a collision: if you had to go around an L-bend with a particle, like they do with automobiles on a highway [laughs].

Question: You mean these waveguides go right through the nuclei?

Right, they're linear, so they don't have any acceleration to the right or to the left. The extranuclear electrons are also oriented by such a nucleus. We don't find the orbit as a whole rotating around the nucleus; it is locked in place. So that is part

of the waveguide. It tends to focus the deuterons down into the nuclear part. Many things can happen under these conditions.

Deuterium's 'Love Tunnel'

Question: It's a "love tunnel" for deuterium!

Yes, and if they are coming from opposite ends, love is made! You have helium being formed.

Question: This is a self-focussing process.

And you can have acceleration. Remember that you have electrons on the outside which are determined by the protons and neutrons in the nucleus and their alignment, and you have an oscillation: How can that nucleus not move, when the electrons around it are moving, at different velocities? So you have a possible accelerating mechanism operating, like a travelling wave used to accelerate particles in a waveguide, with a resonance condition. It's a multiple electrode accelerator.

Question: You did calculations showing that Rutherford's scattering results were a wrong interpretation of the data.

I didn't publish it, and haven't yet, because I thought someone would pick it up.

Question: The same mistake is repeated in all the textbooks.

Right.

Question: This leads to the idea that the nucleus is a hard, spherically symmetrical ball with a spherically symmetrical Coulomb field around it. But this is a fiction, and actually the field of the nucleus is something very complicated.

Absolutely.

Question: How did you come to look at the nucleus in this way?

In physical chemistry you study all the nuclear structure. That is one thing that we went way ahead on at the University of Chicago. And we had people like von Grösse coming over. He had similar ideas, too, and later on we had some other people joining us. But von Grösse was there, and he was like a messenger, telling us what was going on in Germany. It was he who brought back the work of the two German scientists who discovered fission. That put us in the Physical Chemistry Department way ahead in this work, because we had developed so many things in physical chemistry, and von Grösse was the agent who brought the information back from Germany.

When it started up, Lawrence invented the cyclotron. He would come and stop off [in Chicago], having been at the Physics Department at the University of Chicago, but he was out in California. Chicago was always the central place to stop, on the trains. He ended up with the amazing statement: should we call this nuclear chemistry, to be right about what was



Philip Ulanowsky/EIRNS

Tannenbaum: "I hope that this piece of good news on cold fusion will be a revelation for a lot of scientists and students, that the Universe does not work on entropy." Here, Dr. Tannenbaum addresses a "Food for Peace" conference in Chicago, 1988.

going on, or should we continue to call it nuclear physics? I thought that was great.

Question: Why don't we call it nuclear chemistry?

The physicists had the most votes. I wanted to go into physics when I came in 1930, but they had gotten [Arthur] Compton there, and he was studying cosmic rays. And that was the real thing in high energy. So he didn't think too much of physical chemistry at that time. . . . He changed over later.

Question: You were working on interesting properties of the rare earths. How did you get into that?

Because, why are they like they are? Why are there 14 members? You get to realize that if you have the nuclear structure correct, you will have that. That was my approach to it. The regular solids are crucial. With the rare earths you have 14 places to be filled up to make the cage for the nucleus. You are crossing bumps in the rare earth series, which tends to make them add another series of 14 orbits, in such a way that they all have the same charge on the nucleus, the way the electrons neutralize it.

Question: What kind of properties of the rare earths can be understood in terms of this model [of the nucleus]?

They all have the same valence. You are filling up inner shells. You have three electrons in the outer shell, permitting putting 14 in the inner shell.

Question: How do you relate this work to the plasma focus, where we see fusion going on in a very special type of structure, the Beltrami vortices? There must be some correspondence between this and the palladium fusion.

You have to look at something else: superconductivity. You can cool a metal down to zero where you don't have so much vibration, and then you try to make an alloy where you can operate at a much higher temperature.

Question: Why would an alloy allow you to work at a higher temperature?

Because the alloy is such that there are forces holding the superconductor electrons, so you have channels like you are getting in palladium. You have these channels among the nuclei of the high-temperature materials, trying to make alloys that will come up close to room temperature. I worked with a fellow who thought that before the superconductors, we should transmit power in liquid nitrogen-cooled copper. He thought this would be a superconductor for high-voltage AC. Unfortunately, he died a few years later.

Question: How does this relate to the plasma focus?

It is exactly the same sort of thing. In superconductivity you are making channels that electrons can go through without hitting those stationary electrons, or near-stationary ones, attached to a nucleus. So there is no loss. You might say, how about the eddy cur-

rents that are produced? Well, the eddy currents in the outer conductor are always such that it reflects back, doesn't it? It is not losing any energy. So he worked on that, and I often visited his plant when he was working on that. We could get our electricity bills down. This kind of superconducting transmission line will be important, as we get our population density up. Electricity is a very beautiful type of energy to transmit around.

Question: One point which Chuck Stevens has been looking into is the original Ampère law on electric current. One of the things which is coming up now, is that we haven't really understood what an electric current is.

That's right. Although it is easy, in classes for children, to get them to understand that very rapidly. Dealing with Ampère's law, I asked them to think about improvements. So they could be thinking about that kind of thing. They measured the torque between two coils, and the measurement of this torque was a very beautiful experiment for kids to do. They really enjoyed that, the torque on the middle coil produced by interaction with the long solenoid that they had built.

Question: But I understand that you arrived at your nuclear model in thinking about the Klitzing effect, which deals with electrons conducting in a very thin surface. How are you seeing that happening in a solid?

The fact that you have electrons going around in any one of the orbits, one or two or three electrons, and so forth, determines how much you are going to have to divide the maximum field which you use, to try to stop the electron current. But then you get down to the levels at which it is a superconductor. That is around 50,000 volts, and you keep bringing it down until you come to a rather low voltage, which corresponds to the things you are measuring in a magnetic field, the way the superconductivity moves.



Philip Ulanowsky/EIRNS

Dr. Moon at a summer camp near Leesburg, working with youth in 1986 on winding coils to do the Ampère experiments. Robert McLaughlin (l.) assists.

Question: In current you are dealing not with separate electrons, but with a waveguide effect of specific configurations of electrons.

Absolutely true. And when we use waveguides for electromagnetic waves themselves, then again it is the movement of the electrons in that conducting shell around it which determines the type of waves that are propagated. And whether you want to use triangular, or rectangular, or circular, or elliptical geometry, you have a very nice geometrical problem, which is solvable.

Biological Fusion?

Question: Let us get into something different, but quite interesting: biology and biophysics. Some people have speculated that there are fusion reactions going on in living organisms, as a functional aspect of living processes.

If we take the fact that energy is so important for a living organism, such as a human being, which is a quite complicated living organism, it is a very important thing to have some additional energy coming in. To use this in medicines would be very important. We now have some radioactive compounds with the right kind of half-lives, which we could introduce into a medicine that will produce a little energy without a chemical reaction in the system, for the right length of time. This could help in many diseases.

If you look at many diseases, particularly the ones Dr. [Chaovane] Aroonsakul has been looking at,¹ you see the fact that body temperatures get down very low—particularly in some diseases of the nervous system. So, why not bring up the temperatures? She is now looking at some substances which can keep the body temperature up without there being a chemical reaction.

Question: Nuclear processes are crucial in biology. This is clear especially from the work of Dr. [James] Frazer and others on nuclear magnetic resonance. You are seeing living tissue doing many of the things we were discussing before—superconductivity, and perhaps even transmutation of elements. But let us get back to palladium fusion. What do you think of the possible applications? It seems to me one of the problems is to increase the energy flux density at the point where the energy is being generated. The best thing would be to be able to get coherent radiation from this kind of cold fusion, rather than heat, which would be a stupid thing to produce.

That would be a very good thing to achieve.

Question: Because you want to get the energy out in a coherent form and you want to maintain the geometry of the palladium; you don't want to disturb the geometry that is doing the job for you.

That's so correct. And this can be done.

Question: That seems to me to be the crucial point in this busi-



Stuart Lewis

Dr. James Frazer, then of the Texas Medical Center, discussing his work on nuclear magnetic resonance, at a 1984 meeting of the Schiller Institute.

ness. If we want to increase the energy flux density, we not only have to have the fusion going on, but we have to get the energy out in the best way.

So we have to have mechanisms using the application of a signal. This is not out of the question at all.

Question: So we can modulate the process by putting a field onto the palladium.

It's just like a doctor telling a cell, "Well, now you have to behave this way." The signals have to be rectified so as to get the cell to perform the way we want it to.

Proposals for Cold Fusion Research

Question: So what would you propose should be done in experimental work on cold fusion right now?

You get down to what we did with the old cloud chamber. We can start with a few palladium molecules, in gaseous form, at a low temperature, or something like that. Just have a particle coming in, guided like the extranuclear electrons were doing, with the atoms aligned by external fields. We could study these things in this way, using some of the old methods. We need the collision angles and such things.

Question: What other materials would be interesting, besides palladium, to get the waveguide effect for fusion?

Well, palladium is one of the best. But take the completed solids, from the very beginning on up. That should be studied. And you know we can produce elements that are twice the weight of uranium, at twice the atomic number.

Question: We can probably do this in the waveguide geometry.

Right. That is what brings it about. We got to element 109—I think that is the last element we can identify. Then we have a few coming in, where we can't get stability; they don't last. But when you get up to around twice 92, around 180, then there seems to be stability again. The number 137 is also involved. There are so many discoveries to make. If we put the right combinations of these numbers into a mathematical function, then we get something new. And I think the good Lord is helping us to get there.

Question: I hope that this piece of good news on cold fusion will be a revelation for a lot of scientists and students, that the Universe does not work on entropy.

Right. But I think in all these studies it is very important to bring in biology and medicine. And you know we are told in Revelations, Chapter 20, about the thousand years we are going to live. So we have to prepare ourselves for that thousand years. And we have to make the world ready for us to live a thousand years, without destroying each other.

Notes

1. Dr. Moon worked with Chaovane Aroonsakul, M.D., who specialized in gerontology and developed a treatment for alleviating the symptoms of Alzheimer's disease.

Every Electron Communicates With Every Other

These are short excerpts from an interview with Dr. Moon which appeared in the Oct. 30, 1987 issue of Executive Intelligence Review.

On Electron Communication

[When I was working on my doctorate] "I decided to study the diffraction patterns created by electrons, in the surface of oleic acid. (This acid is made by purifying olive oil in a vacuum distiller over a period of several weeks.) I was trying to observe the wave properties of particles, which de Broglie had identified. I was very excited to realize that rather than existing as isolated particles, every electron communicated with every other.

"De Broglie's work raises very profound philosophical questions, because it is necessary to account for the fact that electrons travelling through a narrow opening, a slit, interact with each other—as waves—even when this would apparently not be possible. For example, when one electron follows the other with a time interval of an hour between, still they 'interfere' with each other, so that the first electron exhibits diffraction rings. It appears to know and react to the existence of the second electron.

"I decided to devote my doctoral thesis to carrying out more delicate experiments with electron diffraction, based on the theories of de Broglie. I studied the electron diffraction of the surface of liquids with a very low-energy electron beam—less than 50 electron volts. With electron diffraction, I was able to 'see' the structure of liquid surfaces. In fact, I was able to find the structure of molecules that way.

"These developments related directly to other exciting things, more recent developments, which in turn led me to the realization of my [nuclear] model."



Philip Ulanowsky/EIRNS

Dr. Moon (second floor window) with summer camp students in 1986, experimenting with the effect of atmospheric pressure on sucking water up through a straw.

On the Value of Experimentation

"The freedom to experiment in a laboratory is an essential part of a young scientist's education. You can't learn to be a scientist by passively taking in what someone else accomplished."

The exciting thing is to define a problem, and then develop the tools which you need to tackle it. That's why my early experience in our farm machine shop was so important to me. Every child should be given a similar kind of opportunity, even before he or she enters college.

I would urge college students today, not to get dependent upon computers to do their experiments for them. Even in a larger college setting, there is opportunity to get access to a laboratory for individual experiments.

The trick with a physics department or a chemistry department or a biochemistry department, if you want to do a few extra experiments on your own, is to locate equipment that hasn't been used; there's usually a lot of that around.

On the Need For Units

"It is common today to write formulae neglecting the units of measurement and values, such as magnetic permeability and the dielectric constant.

The question of the standard of measurement is obscured, and even more important, the question of the structure of space is ignored. This takes the student away from the reality of an experiment, where the permeability of free space, or of a particular medium is crucial—for example in the simple case of a condenser."

7. Moon and the Chicago Cyclotron

The Chicago cyclotron, the second in the world, and vastly superior to the first machine for which Ernest O. Lawrence won the 1939 Nobel prize, was designed and built by Dr. Moon and a team of students of Physical Chemistry Professor William Draper Harkins at the University of Chicago in 1936. (See also pp. 38-39.) The Chicago cyclotron was world famous and essential to the building of the world's first atomic pile under the university football field during the Manhattan Project. However, Moon and Harkins's pioneering role with the cyclotron, as with many other of their contributions to nuclear science, became so little known, even suppressed, that many people later thought the machine must have been built by someone else.

We reprint here two letters shedding interesting light on this.

Not Fermi, Moon

This letter-to-the-editor appeared in the Nov. 11, 2003 issue of the Chicago Maroon, the independent University of Chicago student newspaper.

Your obituary of Telmer Peterson in the Nov. 7 issue of the *Maroon*, states that Peterson helped Enrico Fermi build the University of Chicago's first cyclotron. For the record, the University's first cyclotron was built before World War II—and before Fermi arrived—by the late Robert J. Moon (Ph.D., Chemistry, 1936). For example, see Robert J. Moon and William D. Harkins, "The Production of High Velocity Particles in a Cyclotron by the Use of Multiphase Oscillators," *Physical Review*, Vol. 49, p. 273 (1937). Although this brief paper barely hints at the truth, I was told by the late Franklin Offner (Ph.D., Physics, 1938) that Moon actually conceived of the concept of phase stability (synchrotron) usually attributed to independent work by Veksler and McMillan (1945).

**Robert Michaelson
Evanston, Ill.**

Birth of Synchrotron

This letter-to-the-editor appeared in Physics Today, August 1984, p. 73.

In his article on the birth of the synchrotron (February, page 31), Edwin McMillan mentions his letter to the editor of the *Physical Review*, in which he said in reference to his getting the idea for the synchrotron, "It seems to be another case of independent occurrence of an idea in several parts of the world, when the time is ripe for the idea."

He probably should have added to that statement, "and you are lucky enough to be in a place where people will listen to new ideas."

The first time I heard this idea—in almost the same words McMillan wrote to Lawrence—was from Robert Moon at the University of Chicago. It was in 1939 at the seminar where Sam Allison first spoke about the discovery of nuclear fission and the possibilities of a nuclear bomb; perhaps it is because of the juxtaposition of the two events that I so vividly recall it. Moon said to me, "People say that there is a relativistic limit to the power of a cyclotron, due to defocusing with the relativistic increase in mass. But I think it would be easy to overcome this by just fre-



Robert J. Moon

The half-assembled Chicago cyclotron magnet. Dr. Moon machined the magnet himself.

quency modulating the Ds to keep up with the particle mass."

Nothing happened to Moon's idea at the time, just as he was unable to get the co-ax line used on the cyclotron he had designed and built in 1936. The head of the project said it would have to be built like that at the University of California, since Lawrence was the expert! So it was Dunning who built (and received credit for) the considerably improved cyclotron with the far more efficient co-ax tuned circuit.

Moon is still active at the University of Chicago, where he now has been for over 50 years. And I have been unhappy about his not getting the credit he should have received, for over 30 years!

I have checked my recollection with Moon, who confirms my memory precisely. We seem neither of us to have lost our memory, despite our advancing years!

**Franklin F. Offner
Northwestern University**

Proposal for a Fundamental Experiment in Electrodynamicics

EDITOR'S NOTE: The Fundamental Electrical Law of Wilhelm Weber (1846) was based on the conception that the force between a pair of moving charges varied with their relative velocity and acceleration. James Clerk Maxwell later noted that this would imply the existence of a force between a current-carrying wire and a static charge. As no such force had been detected, doubt was cast on the truth of Weber's law. However, the velocity of electrons in a wire, the so-called "drift velocity," has been calculated to be extremely slow (on the order of 0.1 mm per second, for a current of 1 ampere in a wire of 1 mm² cross section).

Dr. Moon's proposed experiment, submitted to the University of Chicago Physics Department in 1958, proposed to detect the Weber force by rotating the current-carrying wire at a high velocity. It was not funded. Since then, experiments by W.F. Edwards, et al. [*Physical Review D*, Vol. 14 (1976), pp. 932-938] and others have shown evidence of the interaction.

Proposed Investigation of the Interaction Between a Steady Current and a Stationary Electric Charge

For the period Dec. 1, 1958 to Nov. 30, 1959
by Robert J. Moon

Maxwell¹ and others² have envisioned a possible interaction between a closed circuit at rest through which electric charges are moving, and an open circuit that possesses a net + or - electrostatic charge. Until recently, however, no experimental means have existed to measure the feeble forces involved in such interactions. With the great improvements in quartz fiber technique made during World War II by T.J. O'Donnell, of the University of Chicago, a torsion microbalance is now available that has an ultimate sensitivity of 10⁻⁹ gram. This sensitivity is adequate for determining the presence and the magnitude of the forces involved in these interactions.

The experimental set-up involves a metallic conductor in the form of a flat ring attached to one arm of the quartz microbalance. An identical ring is attached to the other arm. These two rings are given a net electrostatic charge of suitable sign and magnitude. Directly beneath each ring and 0.1 cm away is located a thin, flat spiral coil of copper ribbon. Each of these coils represents a current-carrying circuit. The axis of each coil coincides with the axis of its respective ring. Each coil is capable of independent rotation about its axis at speeds up to 60,000 rpm. By superposing high physical velocities upon a current-carrying circuit, thus enhancing the electron drift velocities, the force between that circuit and a stationary charge may be amplified many times. The microbalance and the coils are located *in vacuo* in order to minimize Brownian movements and also to reduce effects of moving air as the coils are rotated. Various shields will be provided to avoid spurious effects due to temperature gradients and stray magnetic fields. Electrostatic shields will be placed above each charged ring in order to neutralize effects due to

induced charges. These shields will improve the sensitivity of the measurements when suitable potentials are applied.

Our calculations, based on the Ampèrian law of force between charges, show that, with a spiral coil of 7.62 cm mean diameter, and a metallic ring charged up to a potential of 1,000 volts, a force of the order of 0.1 microdyne will result. If, now, the coil is rotated at a speed of 500 rps, this force will be amplified nearly 10,000 times. Thus, it is seen that the forces generated come well within the range of sensitivity of our measuring instruments. This experiment also enables a measurement to be made of the force as a function of the velocity of the circuit and of the intensity of the current.

The sensitivity of our experimental arrangement should permit the settlement of the fundamental question of electrodynamicics concerning the existence of a force between a stationary charge and a steady current.

The demonstration and measurement of a force between a stationary charge and a steady current will lead to important practical applications. For example, in the control of a plasma by means of an axial magnetic field, the ultimate field intensity is limited by the conduction current through the coils generating the field. However, by physically rotating the coils about the axis, it should be possible to augment greatly the effect of the current alone.

Notes

1. J.C. Maxwell, *A Treatise on Electricity and Magnetism* (Oxford at the Clarendon Press, 1881), 2nd Edition, Vol. II, Chapt. 23.
2. P. O'Rahilly, *Electromagnetics* (Longmans, Green and Co., 1938), p. 588.

Budget	
Salaries	\$ 15,488.88
Equipment and supplies	11,735.00
Overhead, 38.9% of direct salaries	6,025.18
	\$ 33,249.06
Salaries	
Robert J. Moon, 1/5 time, 2 quarters	\$ 1,600.00
Robert J. Moon, 1/2 time, 4th quarter	888.88
A. E. Shaw, physicist, full time	8,400.00
A.F. Hughes, Secy., 1/2 time	2,100.00
Student assistant	2,500.00
	\$ 15,488.88
Equipment and Supplies	
D.C. power supply (Sorenson-nobatron)	\$ 950.00
3-phase power supply (Sorenson)	1,850.00
High vacuum system (pumps, gauges, etc.)	1,500.00
Two 3-phase motors	200.00
Special non-magnetic table	125.00
Liquid nitrogen	600.00
Special measuring equipment	1,400.00
Magnetic shielding	65.00
Miscellaneous supplies	1,150.00
Machine Shop service, 600 hrs at \$6.50/hr	3,900.00
	\$ 11,735.00
Estimated time to complete project—12 months	

9. Dr. Moon in the News

Dr. Robert J. Moon was a modest man, and even those of us who knew him well were surprised by some of the material in the treasure trove of newspaper clippings about him, which were graciously provided to *21st Century* by the News Office of the University of Chicago. A selection of the news articles is summarized here.

Note that spelling corrections and punctuation were added to the transcripts of newspaper articles.

—Marjorie Mazel Hecht

Dr. Moon and the Atomic Energy Act

■ *The New York Times*, Aug. 14, 1947

Atomic Law Bars Job to Physicist

Dr. Moon, Who Helped Evolve Bomb, Seeks Permit to Take Canadian University Offer

CHICAGO, Aug. 13—For the past eight months, Dr. Robert J. Moon, nuclear physicist at the University of Chicago, disclosed today that he had been petitioning the Atomic Energy Commission and other Federal agencies in Washington for permission to take another job without fear of being imprisoned or facing a possible death sentence for unintended treason.

The scientist, who is 36 years old, and assisted here in fundamental research that led to development of the atomic bomb, now holds the post of Assistant Professor of Physics at the University's Institute of Radiobiology and Biophysics. He would like to quit that position to take an offer of a new assignment as head of the Physics Department at McMaster University at Hamilton, Ont.

Dr. Moon, who built the cyclotron (atom smashing machine) at the University of Chicago, had accepted the Canadian school's appointment and delivered one lecture there last December. It was then, he said, he was advised that his continued teaching in a foreign country on the subject of nuclear physics might place him in jeopardy under the provisions of the United States Atomic Energy Act.

This law contains sections on engaging in production of fissionable (atom

Measuring Device Made To Be Inserted in Heart

Special to THE NEW YORK TIMES.
CHICAGO, Feb. 14—Lynn Williams, vice president of the University of Chicago, disclosed today that atomic scientists at that school had developed a new kind of radioactive measuring device that was so small it could be inserted inside a beating heart to detect abnormalities in

Hearing Perfection

New TV X-Ray in Cancer Hunt

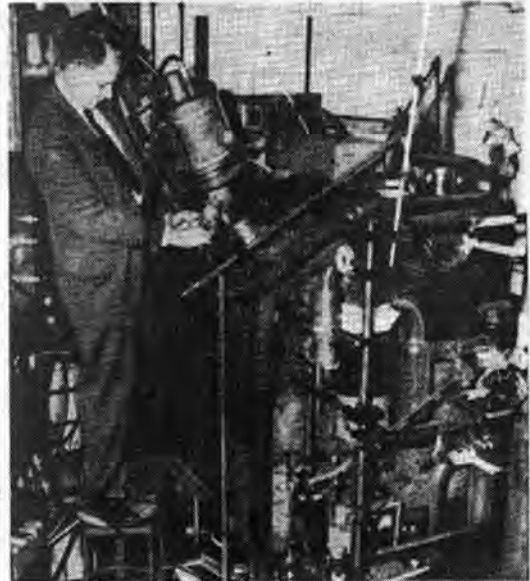

ATOMIC LAW BARS JOB TO PHYSICIST

Dr. Moon, Who Helped Evolve Bomb, Seeks Permit to Take Canadian University Offer

Special to THE NEW YORK TIMES.
CHICAGO, Aug. 13—For the past eight months Dr. Robert J. Moon, nuclear physicist at the University of Chicago, disclosed today that he had been petitioning the Atomic Energy Commission and other Federal agencies in Washington for permission to take another job without fear of being imprisoned or facing a possible

Says 69 Scientists Tried To Prevent Hiroshima

WASHINGTON, Dec. 30 (INS).—A top U. S. atomic scientist said Thursday night that 69 men who helped to create the world's first A-bomb asked former President Harry S. Truman to bar its use against Japan in World War II.

Prof. Robert J. Moon, of the University of Chicago, said that he and his colleagues urged Truman to have the bomb exploded on a remote Pacific Island, instead of on Hiroshima and Nagasaki in Japan.

HE SAID the group also suggested that military commanders and statesmen from all nations should be present at the event. Prof. Moon made his statement

Physicist's legacy won't melt down

By George Papajohn

Robert J. Moon kept pens in his coat and rusted cars in his garage. He kept his coat in the trunk while shoveling snow. He knew that the scientist's eccentricity, like Einstein and banker, was keeping his materials in his basement.

Atomic Energy Converted Directly to Electric Power

Special to THE NEW YORK TIMES.
CHICAGO, Sept. 27—Chicago scientists have discovered the first practical method for the direct conversion of atomic energy into electric power. Their accomplishment, acclaimed as a significant

splitting) material outside the United States and exchanging secret atomic information with other nations. The penalty for violation "with intent to secure an advantage to a foreign nation" is death, Dr. Moon related.

When he was advised of his possible peril, Dr. Moon said, he immediately left Canada on the suggestion of his father, Fred A. Moon, an attorney and former Greene County (Mo.) Democratic committee chairman and personal friend of President Truman.

Since that time, the Canadian Embassy, the Canadian Department of External Affairs, the American State Department, the Department of Justice, the Atomic Energy Commission, the Director of Planning and Development of McMasters, and Representative Marion T. Bennett, Republican, of Missouri have all tried to do something about his case, Dr. Moon disclosed. . . .

The [Atomic Energy] Commission's legal staff concluded that the case was part of a greater issue involving the question of inter-

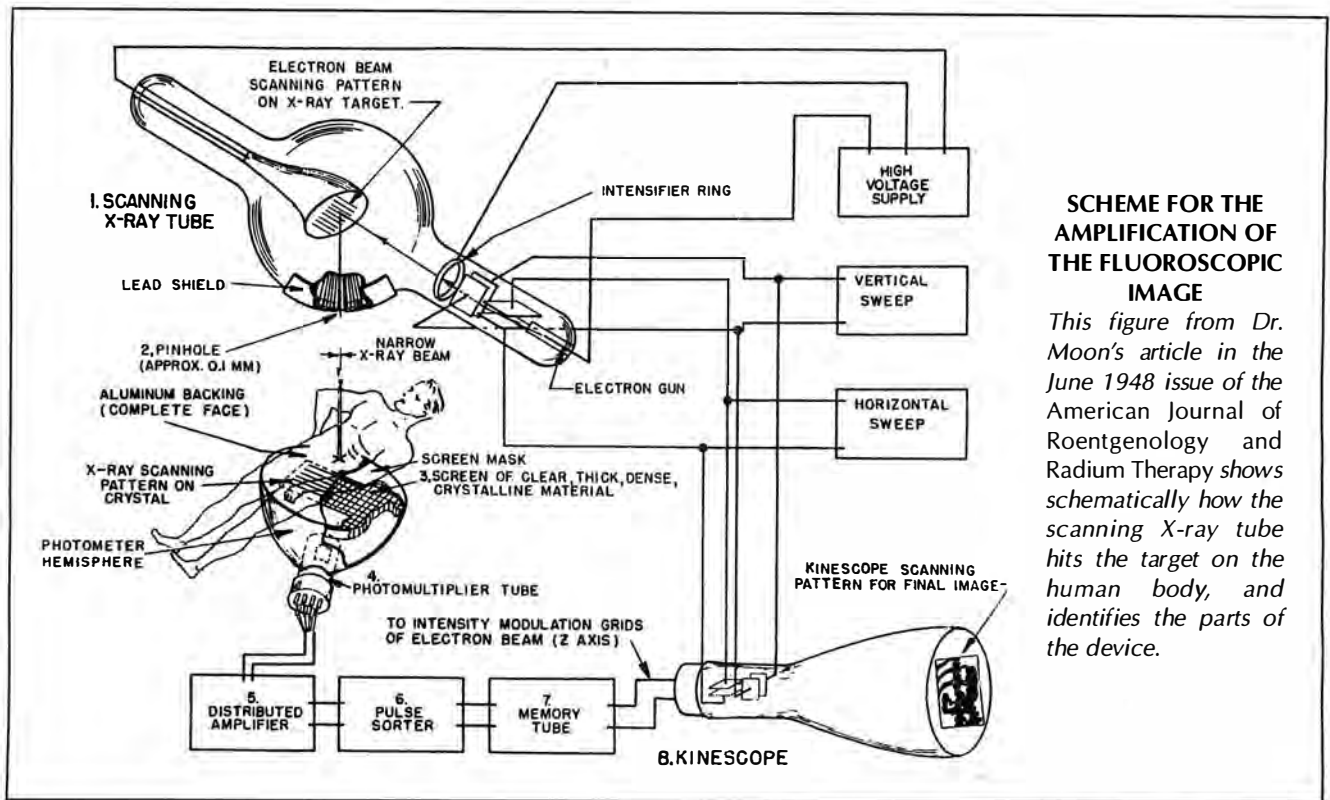

SCHEME FOR THE AMPLIFICATION OF THE FLUOROSCOPIC IMAGE

This figure from Dr. Moon's article in the June 1948 issue of the American Journal of Roentgenology and Radium Therapy shows schematically how the scanning X-ray tube hits the target on the human body, and identifies the parts of the device.

national relations on atomic energy. . . .

■ *The Washington Post*, Aug. 15, 1947

Atomic Group Sidesteps Rule On Physicist

By the United Press

The Atomic Energy Commission said last night that it cannot give Dr. Robert J. Moon, 36-year-old University of Chicago nuclear physicist, "any assurance or guarantee that his future actions will not involve a violation of the Atomic Energy Act. . . ."

■ *The Chicago Tribune*, Aug. 14, 1947

Atom Law Bars U. of C. Scientist from Alien Job by Roy Gibbons

Dr. Robert J. Moon, nuclear physicist at the University of Chicago, disclosed yesterday that for the last eight months, he has been petitioning the Atomic Energy Commission and other federal agencies in Washington for permission to take another job without danger of being imprisoned or facing a possible death sentence for unintentional treason. . . .

"Because of public hysteria associated with anything related to atomic energy or the atom bomb, and since we've just

entered the new atomic age, no one wants to make an interpretation of the law," Dr. Moon commented. "Everybody's scared to death and the tendency is to want to take things easy."

Dr. Moon's Radioactive Measuring Device

■ *The New York Times*, Feb. 15, 1949

Measuring Device Made To Be Inserted in Heart

CHICAGO, Feb. 14--Lynn Williams, vice president of the University of Chicago, disclosed today that atomic scientists at that school had developed a new kind of radioactive measuring device that was so small it could be inserted inside a beating heart to detect abnormalities in the functioning of that organ.

The instrument is the creation of Dr. Robert J. Moon, associate professor in the University's Institute of Radiobiology and Biophysics.

Dr. Moon said that if the meter was used on human beings, it would be inserted into their hearts through a vein or artery. The meter, which is less than half an inch long, glows in the presence

of radioactive substances.

If heart medicines were made radioactive, the device would record the heart's efficiency in utilizing such drugs, it was explained.

Dr. Moon's Scanning X-ray Device

■ *The American Journal of Roentgenology and Radium Therapy*, November 1949 (Vol. 62, No. 5)

Amplifying a Fluoroscopic Image

Discussion of Symposium on the Intensification of the Roentgenoscopic Screen

. . . DR. ROBERT J. MOON, Chicago, Ill.: When Dr. Paul Hodges presented the problem of the amplification of the fluoroscopic image to me about a year ago in casual conversation, it was just one of those interesting discussions at the time. However, it was well to have this information in mind; for subsequent developments that occurred last February in some work which we were doing in our Institute of Radiobiology and Biophysics appeared to be immediately applicable

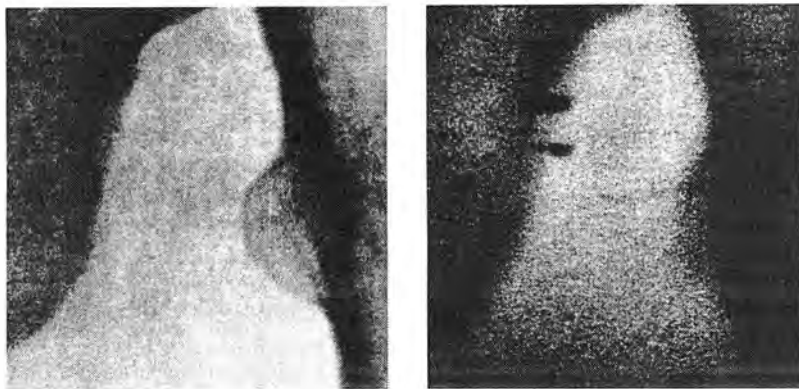

At left is the standard X-ray view of a femur (facing toward the ischium), taken with a total dosage of 10 roentgens. At right, is the same view taken by Moon's scanning X-ray system. Although the total dosage is 5.3 milliroentgens—1 two-thousandth of the then-standard dose—the image is far superior in detail.

to the amplification of the roentgenoscopic [X-ray] image. A scheme for the solution of Dr. Hodges's problem was drawn up and discussed with him, the result of which was that he urged this line of approach be investigated as to its possibilities. Preliminary measurements showed the feasibility of the idea. This particular method was described in a communication which appeared in the June 1948 issue of the *American Journal of Roentgenology and Radium Therapy*. The general scheme of the method is shown in Figure 1 of that paper. [See Figure, p. 48.]

About three months ago, the above paper was discussed with Dr. Szegho, Dr. Polanyi, and Dr. Marcy of the Rauland Corporation, and these gentlemen were all very much interested in the general nature of the problem, and specifically in the adaptation of one of their projection kinescopes as a scanning roentgen tube for the amplification of the fluoroscopic image. Two such scanning roentgen tubes are now in operating condition. We took our first photograph with such a tube last night, although we had been observing some images with the tube in the past few weeks.

The spot where the cathode particle strikes the target in the roentgen tube moves back and forth across the target, and after

each transit, it takes another path across, which is below the preceding path. This is continued until the bottom edge of the target is reached, at which time the spot returns to the upper edge of the target and repeats its trip across

the target as before. The same procedure is repeated many times a second.

This, of course, is just the way the spot scans the face of a picture tube in a television receiver. The roentgen rays which are generated at the spot where the cathode particles strike the anode are permitted to escape only through a tiny pinhole which is essentially part of the wall of a lead box, which encloses this scanning roentgen tube. Thus a tiny searchlight of roentgen rays is generated, which is scanning back and forth with its virtual origin at the pinhole. Thus, after a patient is placed in this roentgen-ray field, and the roentgen rays are allowed to fall on a fluorescent screen, which is placed opposite the patient from the pinhole, a roentgenoscopic image would be seen, just like that with which you are familiar. There is one essential difference, however; if the screen were observed for a very short instant, say a microsecond, and if a fast fluorescent screen were employed, then only a spot would be seen which would correspond to the position of the roentgen rays at that instant. The fluores-

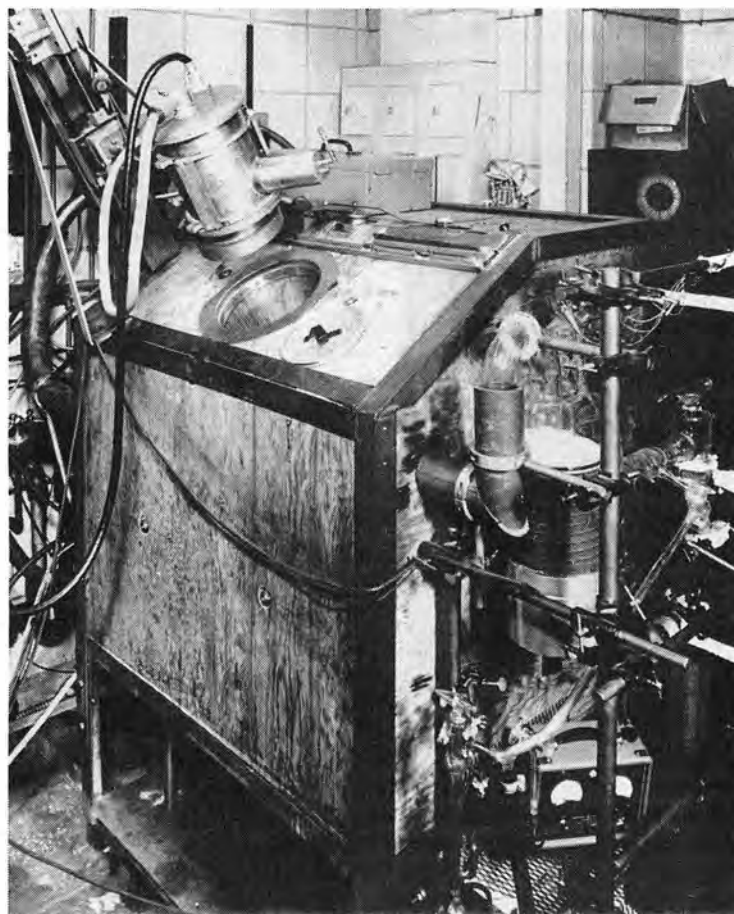

The scanning X-ray assembly. The outer box is a shield of 1/2-inch lead. The vacuum pumps are exterior to the box on the right. The calcium-fluoride single crystal housing and photo multiplier tube is at upper left.

cent light pulses from each particular spot are picked up by the photocell and the photocurrent amplified, so that it can modulate the intensity of the cathode-ray stream of a kinescope in order that the picture may be reconstructed on a picture tube, just as it is done in television. In the particular experiments which are referred to above, a photograph of a roentgen-ray shadow of an image of a small gear was taken with a 525 line picture (transits of the roentgen-ray beam per frame) with thirty frames per second. The photograph is not of the direct fluorescent screen but of the screen of the kinescope.

Many problems were encountered in the development of this system, and the progress has been good towards their solution. . . .

■ *New York World-Telegram & The Sun*, Sept. 19, 1950

Medical Gun Brightens The Inside Outlook
by *Science Service*

CHICAGO, Sept. 19—Doctors will shortly be able to watch an image of what goes on inside a patient's stomach several hundred times brighter than the current fluoroscopic

images. The new device, employing electronic methods and a fluorescent crystal, was developed by a University of Chicago physicist.

"It will permit doctors to make examinations for cancer and other diseases without fear of danger to the patient from too long exposure to X-rays and with a much clearer view of the patient's internal organs. Motion pictures of the image will be possible.

Completion of the equipment, by Robert J. Moon, assistant professor of physics in the University's Institute of Radiobiology and Biophysics, is reported in the current issue of the University's research reports.

Mr. Moon points a television-type

electron gun at a target of tantalum foil. Some of the electrons transformed into X-rays, are focussed on the object to be X-rayed. After they pass through the object, they hit a fluorescent crystal that changes the X-rays to ultraviolet rays. Their signal strength is multiplied many thousandfold and transmitted to a television-like viewing screen.

■ *New York Herald-Tribune*, Oct. 17, 1950

New Detection Method Said to Locate Cancer

Fluoroscopic Device Allows Mass Tests of Internal Organs, Scientist Says

CHICAGO, Oct. 16 (UP)—A University of Chicago scientist has developed a new type of fluoroscope which will permit mass examinations of the stomach and lower intestine for cancer and other diseases, it was announced here.

Present methods employ a dangerously heavy concentration of X-rays to produce an image that is weak and indistinct. The new device, it was said, uses less than 1/100 of

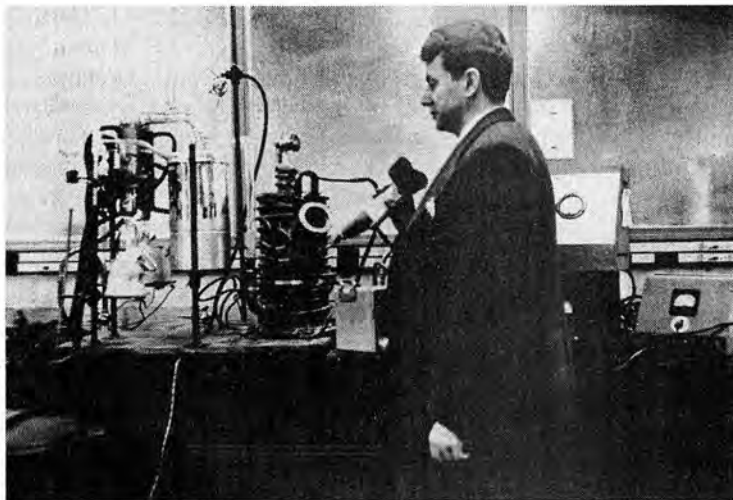

▲ Robert Moon and the vacuum furnace, in which he bonded the alloys for the X-ray target for the tube.

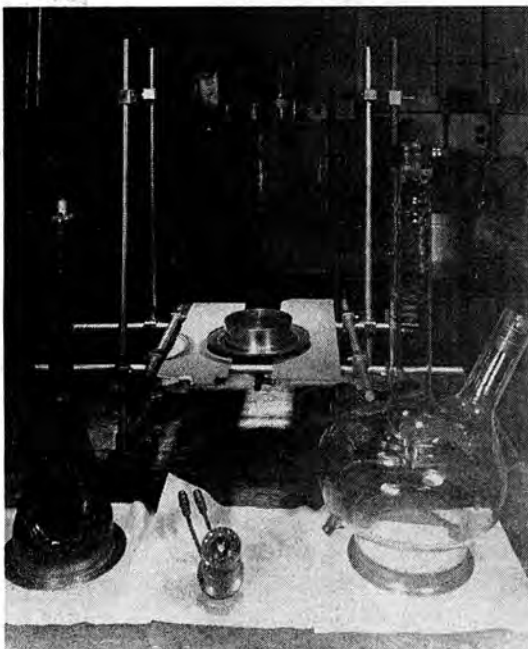

◀ Scanning X-ray tube parts, with the 4-inch target in center and the electron gun at the center front.

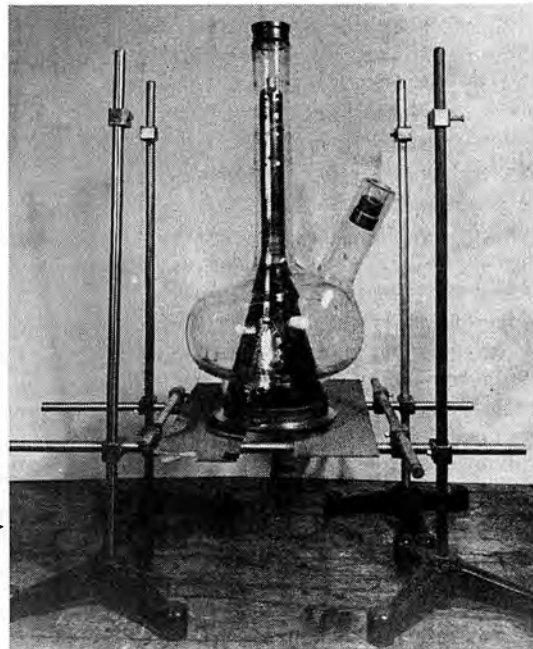

▶ Partial assembly of target glass enclosure and gun anode support.

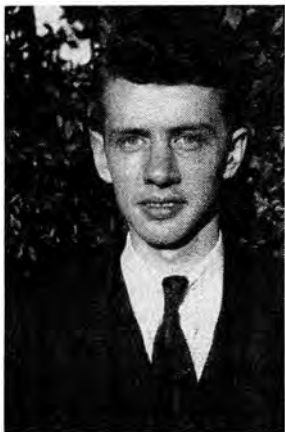

Undated photos of Robert and Christine Moon, sometime after their marriage.

members in Chicago last week learned that:

• A revolutionary electron gun, developed by the University of Chicago's Dr. Robert J. Moon, is being perfected for X-raying hard-to-get-at organs such as the stomach and lower intestines. Using a pinpoint X-ray beam and a scanning system, it throws a brilliant, enlarged image on a TV screen, [and] subjects both patient and radiologist to much smaller

and safer doses of X-rays than older methods. . . .

■ *Newsweek*, June 30, 1952, p. 57

Medical Notes

. . . • Early detection of cancer of the

stomach and lower intestines will be helped by the use of a new machine that televises X-rays, now under development at the University of Chicago's Institute of Radiobiology and Biophysics, by Dr. Robert J. Moon. . . . With the new device, [doctors] will be able to get a clear look through as much as 10 inches of body tissue. . . .

■ *Chicago Tribune*, June 13, 1952

Revolutionary X-ray Picture Gun Invented

U. of Chicago Scientist Talks to A.M.A.

by Roy Gibbons

. . . With adaptations, Moon explained, the device can also be employed as a valuable industrial tool for studies that might include examinations of moving parts inside machinery, or the hidden interior of jet engines being tested on assembly lines. . . ."

the present concentration of X-rays, but produces an image several hundred times brighter.

It was developed by Robert J. Moon, assistant professor of physics, who said he expects to produce soon an improved model of the device. His first pilot model was plagued with a flicker in the image.

Mr. Moon said his apparatus may make possible the setting of bones under the fluoroscope, a practice which has been abandoned because of the faint image obtained with former methods and the danger of exposure of the doctor to X-rays.

Essentially, his device consists of an electron gun which shoots a finely focussed beam of electrons through a tiny hole in a foil of tantalum. Some electrons are transformed into X-rays in striking the foil, but the hole allows only one in 10,000 to pass through.

Mr. Moon developed a new principle of using fluorescent crystals in obtaining a better picture from a lesser amount of X-rays. Rays passing through the tantalum hole strike a single crystal of calcium fluoride and burst into a shower of ultraviolet rays.

Viewing is done with a kinescope viewing tube, the kind used on television screens.

■ *Time* magazine, June 23, 1952, p. 66

Compound Prescription

. . . From hundreds of papers, panels, and exhibits, the 14,000 A.M.A.

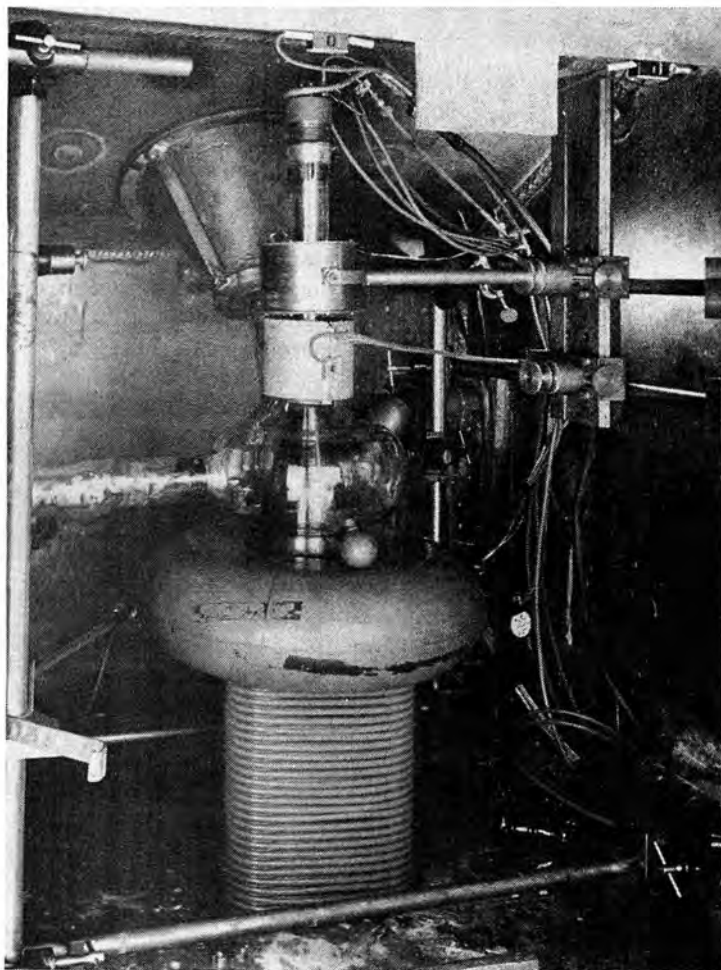

Dr. Moon's scanning X-ray tube shown within a lead shield. The coiled tubing below is for high-pressure water cooling of the 4-inch tungsten target. The re-entrant cone is for the pinhole. The electron beam focal spot and pinhole form the scanning X-ray beam.



EIRNS

Dr. Moon in Detroit, Feb. 23, 1975, where he spoke before an audience of more than 225 workers and others, who formed a Political Action Committee. He is being interviewed after the event by Detroit television.

■ *Chicago-American*, Jan. 14, 1955

Nearing Perfection

New TV X-ray in Cancer Hunt;
Dangers Reduced

by Effie Alley

A revolutionary new TV X-ray is nearing perfection at the University of Chicago. It is capable of detecting cancers deep within the body, when they are

no more than 1/50th of an inch in size.

Because it exposes the person being photographed to only 1/100th of the dosage now required, the device offers an answer to scientific fears that medical use of diagnostic X-ray is reaching dangerous proportions.

Dr. Moon Inventor

Known as the X-ray scanning system, the new machine was described by its inventor, Dr. Robert J. Moon, at last night's

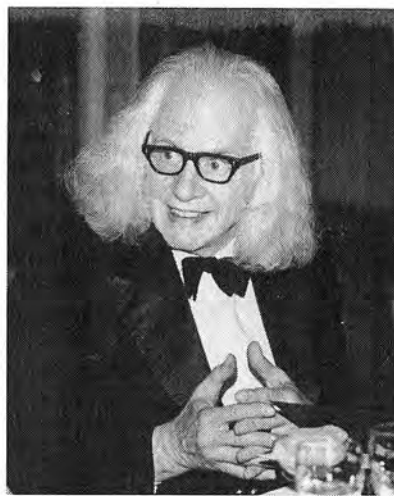

Stuart Lewis/EIRNS

Moon was a speaker at a Fusion Energy Foundation banquet in New York City, February 1981, honoring Dr. Melvin Gottlieb, who had just retired as head of the Princeton University Plasma Physics Laboratory. Moon was Gottlieb's college physics teacher.

meeting of the Chicago Roentgen-ray Society in the Sheraton Hotel.

It represents the first basic change in technique of X-ray examination since discovery of Roentgen rays, Moon, associate professor at the University's Research Institutes, told the radiologists.

Capable of magnifications up to 500 times, it can also serve as an X-ray microscope. In this role, it has been used to guard the Navy's atomic submarine, the *Nautilus*, against metal flaws. . . .

The Neutron Thermometer

■ *New York World Telegram & The Sun*, Sept. 28, 1950

Thermometer May Be Key to Atomic Energy

by the Associated Press

CHICAGO, Sept. 28—Chicago scientists have found a practical method of converting atomic energy directly into electricity. It involves a neutron thermometer previously used only to control atomic furnaces.

The discovery became known Tues-

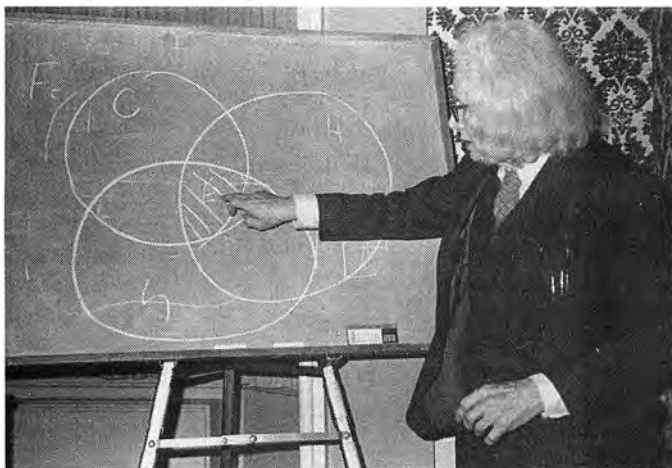

EIRNS

Moon ran for the post of Alderman in Chicago, and here is speaking at a Club of Life meeting on "revitalizing Chicago," Feb. 18, 1983.

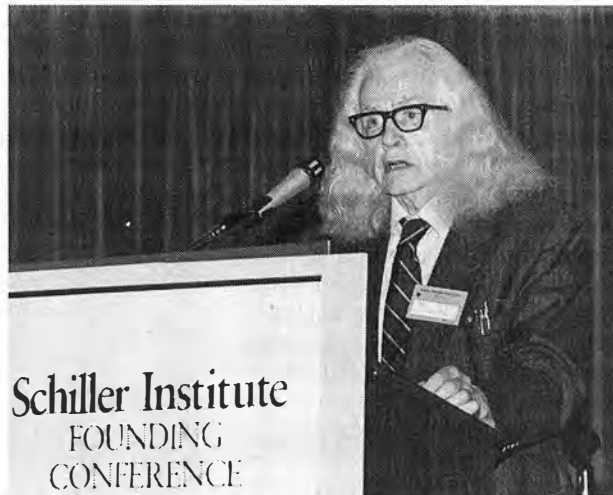

Stuart Lewis/EIRNS

Moon addressing the founding conference of the Schiller Institute, in Arlington, Va., July 3, 1984.



Stuart Lewis/EIRNS

◀ Moon (center) and Larry Hecht right, carry a Beam Weapons banner, getting ready for a Washington, D.C. demonstration, sponsored by the Schiller Institute, in November 1984.

On the campaign trail for the Strategic Defense Initiative: Here Moon is speaking at a May 1983 event in Chicago on the science of beam weapons. ▼

day, when the Atomic Energy Commission lifted its secrecy order on the work, which was started in 1942.

John L. Kuranz, 29, vice president of the Nuclear Instrument & Chemical Corp. of Chicago, and Robert J. Moon, 39, assistant physics professor at the University of Chicago, were leaders in this research.

Mr. Kuranz said electric current so generated approximates only a quarter of a watt. Its only use has been to activate controls on the atomic furnace itself.

But the scientist said the thermometer, measuring six and a half inches long and a half inch in diameter, may be the forerunner of many new atomic measuring devices.

Heat generated by atomic bombardment of fine wires of dissimilar metals in the neutron thermometer is transformed into electricity. The metals are known as chromel and alumel.

■ *Chicago Tribune*, Sept. 29, 1950

Expert Stands Behind Atomic Power Story

Furnished Technical Data for Account
by Roy Gibbons

John L. Kuranz, 29, vice president of the Nuclear Instrument and Chemical Corporation, 223 W. Erie St., said last night he assumed full responsibility for giving *The Tribune* technical information for a story which said that Kuranz and Dr. Robert J. Moon of the University of Chicago had been instrumental in

developing the first practical method for the direct conversion of atomic energy into useful electricity.

The story, published in Wednesday's edition of this newspaper, has been denied in Washington by the Atomic Energy Commission, which characterized the report as untrue. . . .

After the story was written, it was shown to Kuranz, who approved it. The *Tribune* then sent the story to Washington for security clearance by the AEC. . . .

That agency said, "we have no security objection to publication," but added that usefulness of the neutron thermometer seemed to be described in "somewhat extravagant terms," and suggested that the story be reviewed for accuracy by Kuranz and Dr. Moon.

"The *Tribune* did call me and read the story to me twice," Kuranz said. He also recalled that after the story had been read back to him the second time, he commented that it was amazingly accurate and that he found no reason to change it.

Kuranz also pointed out that conclusions regarding the possible effect of the instrument in reducing the size of atomic piles [furnaces] as reported in *The Tribune* were "shrewd" conclusions reached by *The Tribune* writer over which Kuranz said he had no control, but were based on facts he supplied.

Second Scientist Confirms It

As requested by the AEC, *The Tribune* also had Dr. Moon review the story, reading it to him twice. Dr. Moon said the article was correct, with the excep-

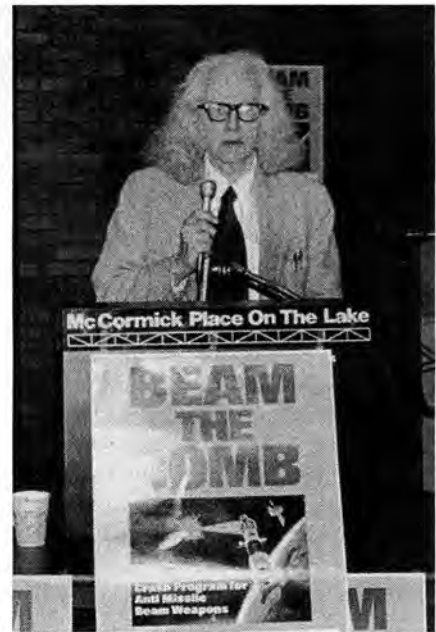

tion of two minor details.

He also said that the principle on which the instrument operated might very well be the forerunner of future developments in drawing greater amounts of electrical current from an atomic furnace after more research had been done in the field of high temperature alloys capable of withstanding heat above 3,000 degrees.

Moon emphasized, in response to questions, that the thermometer was the very first device ever employed to draw an electrical current out of an atomic furnace.

Moon Recalls Attempt to Stop Hiroshima Bomb

■ *New York Mirror*, Dec. 31, 1954

Says 69 Scientists Tried To Prevent Hiroshima

WASHINGTON, Dec. 30 (INS)—A top U.S. atomic scientist said



Stuart Lewis/EIRNS

Moon with his youngest daughter, Peggy, and her family at a birthday dinner in Leesburg, Feb. 14, 1986.

Thursday night that 69 men who helped to create the world's first A-bomb asked former President Harry S Truman to bar its use against Japan in World War II.

Prof. Robert J. Moon, of the University of Chicago, said that he and his colleagues urged Truman to have the bomb exploded on a remote Pacific Island, instead of on Hiroshima and Nagasaki in Japan.

HE SAID the group also suggested that military commanders and statesmen from all nations should be present at the event.

Prof. Moon made his statement after first making an oblique reference to the plan in a prepared speech before the World Assembly for Moral Rearmament.

Explaining the nub of the scheme, he said:

"We believed that (the demonstration) would bring about the capitulation of Japan and end the Second World War without the bomb having to be used against a Japanese city."

THE PROFESSOR said the petition was sent to Truman in the early Summer of 1945, after the scientists assigned to the super-secret Manhattan Project discovered the bomb would work and that one bomb could destroy a city.

The petition, he explained, was drafted and signed by atom scientists at the University of Chicago, where

the first atomic pile was created, and at Los Alamos, N.M., where the initial A-bomb was exploded on July 16, 1945.

Prof. Moon said that the petition and suggestion was sent "through channels" to the President. He explained that this was necessary because the atomic scientists were working under the U.S. Army in the Manhattan

Project.

HE SAID: "We sent it through channels to the 'Four Horsemen'—Conant, Oppenheimer, Lawrence, and Fermi—and they made their own notations on the message, and sent it on to Secretary of War Henry L. Stimson, who, we understand, passed it on to President Truman."

The "four horsemen" were James B. Conant, Chairman of the National Defense Research Committee; Dr. J. Robert Oppenheimer, head of the Los Alamos project; and Drs. Ernest Orlando Lawrence and the late Enrico Fermi, both famed atom scientists.

Prof. Moon said his understanding is that the message was delivered to Truman either while he was en route to the Potsdam Conference or after he arrived there.

Moon on the Religious Significance of the Atomic Age

■ Cincinnati Enquirer, Nov. 18, 1955

Religion Is Linked to Atomic Energy by Lecturer at UC

"The revelation of the atomic age was by a loving God, and there is a



Stuart Lewis/EIRNS

Dr. Moon celebrates his 75th birthday, Feb. 14, 1986, in Leesburg, Virginia, with friends from the LaRouche movement. With Moon are Suzanne and Gerry Rose.

way, therefore, which insures that atomic energy may be a blessing to mankind and not a curse," a nuclear physicist told the University of Cincinnati faculty members yesterday at a campus luncheon.

Dr. Robert J. Moon, nuclear physicist of Research Institutes, University of Chicago, assisted at the birth of the atomic age in the Manhattan Project. He discussed "Atomic Age and Its Religious Significance" yesterday, during the UC student-sponsored Religious Emphasis Week.

"Perhaps the scientist may never know the structure of the nucleus unless he answers the call to live a Christ-like life," Dr. Moon warned.

"There must be no compromises with evil. It is through the recognition of absolute moral standards, and striving to adhere to them that our hearts may become open to the Holy Spirit, that we may have His strength to usher in this new age, and thereby use nuclear energy for the blessing of mankind and make the world an oblation to God.

"December 2, the world will have lived through 13 years of the atomic age. The comprehension of the implications of the scientific and technical knowledge of atomic energy in this period has been, and still is, difficult for the scientist, let alone the layman, despite the fact that our scientific knowledge is limited; for example, even today there is no good theory as to the structure of the atomic nucleus, yet atomic energy is being produced on an ever-increasing scale."

■ Los Angeles Daily Mirror, June 3, 1952

R.J. MOON, University of Chicago nuclear scientist: "Only those people who allow the Holy Spirit to dwell in them and live absolutely moral lives can utilize nuclear fission as a blessing to mankind."



Philip Ulanowsky/EIRNS

After the death of his wife from the effects of Parkinson's, Moon devoted much of his time to teaching children, youth, and adults, the basics of science, especially, electro-dynamics and nuclear science. His summer program for youth involved them in building the apparatus—winding coils, and so on—to reproduce Ampère's basic experiments in electro-dynamics. Here, he works with young teens in the summer camp machine shop. Inset is one of the students using the lathe.



Radioactive Materials in Moon's Basement

■ Chicago Tribune, May 6, 1993

Physicist's Legacy Won't Melt Down

by George Papajohn

University of Chicago physicist Robert J. Moon was known as a bit of an eccentric. But until this week, nearly four years after his death, no one knew that his eccentricity extended to keeping radioactive materials in his basement. Moon's son discovered the materials, which turned out to be harmless. . . .

Robert J. Moon kept pens in his suit pocket and rusting cars in his driveway. He kept his coat and tie on while shoveling snow. . . .

Tuesday afternoon, 3 1/2 years after Moon died, and only a few days before his house was finally to be sold, the professor's son came upon a box with a radiation warning on it.

Not exactly the kind of thing you want to advertise in an estate sale: promethium-147 and thallium-204 in glass vials, radium-226 in brass cylinders, cesium-137 in a petri dish. . . .

Moon kept the materials safely stored inside a small box made of heavy lead bricks.

"I'm certain that these had a very peaceful medical use, if anything," said Tom Orteiger, director of the Illinois Department of Nuclear Safety. "You'd probably get more hurt by dropping one of those bricks on your foot than walking around with one of these rods."

. . . Moon's neighbors never really panicked. Nor did Moon's son. . . .

10. A Reminiscence from the Manhattan Project

by James A. Schoke

I owe and have honored Robert Moon with a lifetime of gratitude, freely expressed to others all of my life, and to him when we were still in contact 'til the late fifties.

In 1943, at 19 years of age, I was in the last class of a senior and graduate level Signal Corps program given to reservists, and conducted in the West Wing of the Rosenwald Museum of Science & Industry. It was called "UHF and Microwave Electronics." Bob Moon directed it, and taught some of the courses. This was under contract with the University of Chicago. It was a 20-week (6- to 8-hours per day, plus homework) concentrated program. I enlisted in the Signal Corps Training program which was supposed to end up at Officers Candidate School (OCS).

Near the end of the course, some of us were interviewed for an undefined secret volunteer mission that would involve radio transmission and receiving equipment in Europe. Luckily, I turned it down. We learned a year or two later that the fellows that volunteered were stationed on mountaintops, tending communication centers as part of the OSS; boring as hell.

A week or so before graduation, we were told there would be no OCS, and we would either go to active duty in the Signal Corps or for radar training attached to the Air Corps. Also, the top ten of us were sent over to the Ryerson Physics Building on campus for interviews for an undefined secret project to work on "electronic instruments and controls." As number 2 in the class, I went for an interview. We were not asked if we wanted to volunteer for this duty, nor were we told if we were successful in our interview.

In the middle of what was to be a six-week Air Corps Basic Training before going to Radar School, I was called up and given secret orders to report in civvies as a reservist (again) to an armory on Cottage Grove Ave. in Chicago, and a train ticket for transportation. I was assigned to the Special Engineering Detachment of the Corps of Engineers, and assigned to work in the Instrument Section of the Metallurgical Laboratory of the Manhattan Project at the University of Chicago in the Ryerson Physics Building.

Dr. Moon, who also joined the Project as soon as our class graduated, had recommended me for this duty—the luckiest break of my life. I did not work in Dr. Moon's Group, because I did not have an advanced degree, but I was able to contribute creative (some patented) electronic measurement and control devices to this fantastic technological and industrial effort.

After discharge in February 1946, I



Photographs courtesy of Jim Schoke

The Manhattan Project's Metallurgical Laboratory students in a 1945 photo. The author is in the third row from bottom, fourth from left.

founded and was President of what became known as Nuclear-Chicago Corp. A few months later, I was joined in this endeavor by two partners, also graduates of that Signal Corps program, and requested by Dr. Moon for the Project. This company was later sold to G.D. Searle Co., and was the first of four technology companies I owned in my working career.



Jim Schoke and his new bride, Elayne, in 1945.

A Kind and Brilliant Man

Dr. Moon was a kind, brilliant man. He was soft spoken, and usually a few steps ahead of anyone he was talking to about a technical subject or problem. Because of this, he was at times difficult to understand, but he was patient, and when reminded would back-track until you understood. He was the proverbial absent-minded professor in looks and demeanor, and sometimes, in behavior. You could converse with him about many things, as he was well-read in a broad array of scientific and nonscientific subjects.

His decision to request my Army transfer to work on the Manhattan Project was the luckiest break of my life.

Some Writings of Robert James Moon and William Draper Harkins

William D. Harkins

- William D. Harkins and R.E. Hall, "The Periodic System and the Properties of the Elements," *Journal of the American Chemical Society*, Vol. XXXVIII, No. 2 (February 1916), pp. 169-221.
- William D. Harkins, "The Structure of Atoms, and the Evolution of the Elements as related to the Composition of the Nuclei of Atoms," *Science*, Vol. XLVI, No. 1192 (Nov. 2, 1917) pp. 419-427, and No. 1193 (Nov. 9, 1917) pp. 443-448.
- William D. Harkins, "The Building of Atoms and the New Periodic System," *Science*, Vol. L, No. 1304 (Dec. 26, 1919), pp. 577-582.
- William D. Harkins, "The Stability of Atoms as Related to the Positive and Negative Electrons in their Nuclei, and the Hydrogen, Helium, H₃, H₂ Theory of Atomic Structure," *Journal of the American Chemical Society*, (Received April 12, 1920), pp. 1956-1997.
- William D. Harkins, "The Constitution and Stability of Atom Nuclei," *Philosophical Magazine*, S.6., Vol. 42, No. 249 (Sept. 1921), pp. 305-338.
- William D. Harkins, "The Periodic System of Atomic Nuclei and the Principle of Regularity and Continuity of Series," *Physical Review*, Vol. 38 (Oct. 1, 1931), pp. 1270-1288.
- William D. Harkins, "Surface Structure and Atom Building," *Science*, Vol. LXX, No. 1819 (Nov. 8, 1929), pp. 433-442, and No. 1820 (Nov. 15, 1929), pp. 463-470.
- W. D. Harkins, "The New Kind of Matter: Element Zero or Neutron [sic]," (Science Service Radio Talks, Presented over the Columbia Broadcasting System), *The Scientific Monthly*, Vol. 36, No. 6 (June 1933), pp. 546-549
- William D. Harkins, "Nomenclature for the Isotopes of Hydrogen (Proto- and Deuto-Hydrogen) and Their Compounds," *Science*, Vol. 79, No. 2041 (Feb. 9, 1934), pp. 138-40.
- William D. Harkins, "Nuclear Chemistry, the Neutron and Artificial Radioactivity," *Science*, Vol. 83, No. 2162 (June 5, 1936), pp. 534-543.

Robert J. Moon

- Robert J. Moon and William D. Harkins, "An Electronic Analysis of Some Surfaces by Means of Slow Electrons," *Journal of Physical Chemistry*, Vol. 40, No. 8 (1936), pp. 941-957.
- Robert J. Moon and William D. Harkins, "The Production of High Velocity Ions for the Disintegration of Atomic Nuclei," *Science*, Vol. 83, No. 2149 (March 6, 1936), p. 244.
- Robert J. Moon and William D. Harkins, "The Production of High Velocity Particles in a Cyclotron by the Use of Multiphase Oscillations," *Physical Review*, Vol. 49 (1937), p. 273.
- R.J. Moon, "Inorganic Crystals for the Detection of High Energy Particles and Quanta," *Phys. Rev.*, Vol. 73 (March 29, 1948), p. 1210.
- Robert J. Moon, "Amplification of the Fluoroscopic Image," *American Journal of Roentgenology and Radium Therapy*, Vol. 59, No. 6 (June 1948), p. 886.
- P.J. Hodges, and R.J. Moon, "Discussion of Symposium on the Intensification of the Roentgenoscopic Screen," *Amer. J. Roent. and Rad. Therapy*, Vol. 62, No. 5, (Nov. 1949), p. 637.
- Robert J. Moon, "Amplifying and Intensifying the Fluoroscopic Image by Means of a Scanning X-Ray Tube," *Science*, Vol. 112, No. 2910 (Oct. 6, 1950), pp. 389-395.
- R.J. Moon, Convention Record of the I.R.E. (1953).
- R.J. Moon, "The Scanning Roentgen System As a Fluoroscope and Microscope," *Acta Radiol. Supp.*, Vol. 116, (1953), p. 479.
- Kuo-Chu Ho and Robert J. Moon, "Electrostatic Potential Plotting for Use in Electron Optical Systems," *Journal of Applied Physics*, Vol. 24,

No. 9 (Sept. 1953), pp. 1186-1193.

Robert J. Moon, "Studies of the Scanning X-Ray System As a Means of Examining Structure," Air Force Office of Scientific Research, AF OSR-TR 59-179 (Chicago: Univ. of Chicago Press, September 1955), 98 pp.

Robert J. Moon and Douglas A. Eggen, "Some Research on the Nature of the Action Potential in Nerve," Air Force Office of Scientific Research, AF OSR-TR 59-153 (Chicago: Univ. of Chicago Press, October 1959), 53 pp.

Curriculum Vitae

Date: Jan. 7, 1941

Name: Robert James Moon

Chicago Address: 5626 Maryland

Department: Physics **Rank:** Instructor

First Appointment began: 1936

Date of Birth: February 14, 1911 **Place:** Springfield, Missouri

Degrees: A.B. (1930), Southwest Missouri State College

PhD., U. of Chicago (1936)

Academic Field of Special Interest:

Nuclear Physics and Electronics

Most Important Research Projects:

- 1) A study of surfaces by diffraction of slow electrons. (1932-36)
- 2) Nuclear disintegration work.¹
- 3) High Speed Scaling Circuits (1935-)

Most Recent Published Works:

- 1) "Analysis of Some Surfaces by means of Slow Electrons," *The Journal of Physical Chemistry*, Vol. 40, No. 8, November, 1936.

Memberships in Learned Societies: Sigma Xi

Wife's Name: Christine Monpleasure

Children:

Mary Elizabeth, age 8 years.

Julia Christine, age 3-1/2 years.

Parents' names (Present Address, if living):

Father, Fred A. Moon, Springfield, Missouri

Mother, Clara I. Moon, Springfield, Missouri

Recreational or Diversional Interests:

Amateur radio, outdoor activities, amateur astronomy.

Notes

1. a) Design work and construction work on University of Chicago Cyclotron. Begun in 1935.
- b) The determination of the ionizing power of particles given off by heavy elements during bombardment with high energy neutrons and deuterons (1939-).

REPORT ON WORK IN PROGRESS

New Explorations with The Moon Model

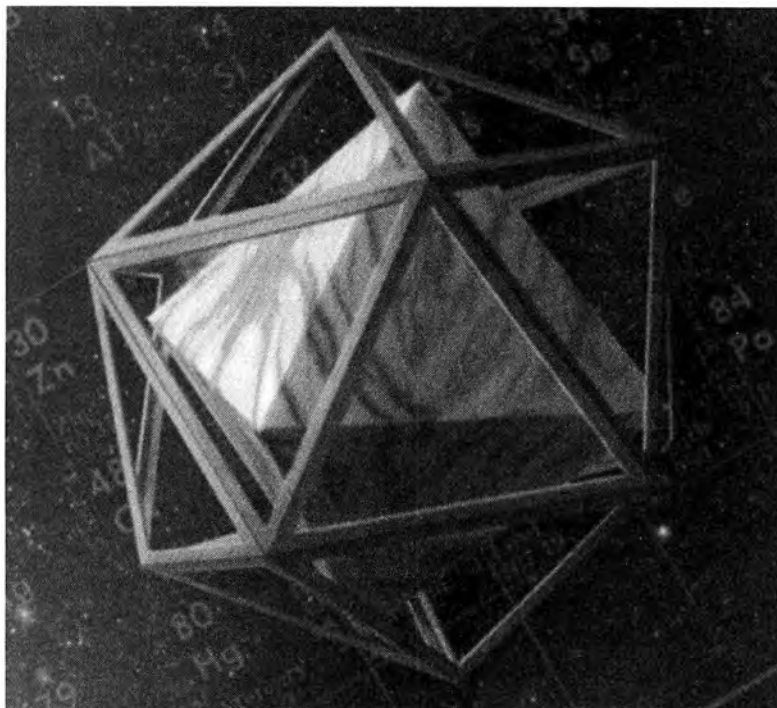

Christopher Sloan (1988)

by Laurence Hecht
with Charles B. Stevens

*Toward a new model of the nucleus, based
on the pioneering work in physics of
Robert J. Moon.*

May 7, 2004

Introduction: Dr. Moon and the Ampère-Weber Electrodynamics

Recently, Charles Stevens and I, with assistance from young Jacob Welsh,¹ have been working on an elaboration of the model of the atomic nucleus developed in 1986 by University of Chicago physical chemist and physicist, Robert J. Moon, Jr. This is a report of that work in progress, quite unfinished, yet full of hope and possibilities for the future. As the work has gone in many different directions, somewhat like the first exploration of an unknown territory, it seemed the time had come to note down on paper some of the paths explored and places seen, before new and yet more inviting vistas draw us beyond, and we forget some of the fascinating detail of what we have already seen.

The main path now seems to lead us to an understanding of the electrodynamic basis for the Moon model. We have discovered a means of analyzing the geometric relationships among pairs of bound protons ("Weber pairs"), which overcomes the usual sort of obstacles one expects in dealing with systems of greater than two-body interac-



Stuart Lewis/EIRNS

Robert J. Moon in 1986.

1. The computer-generated images are developed from *Geometer's Sketchpad* by Jacob Welsh.

tions. As the stable configurations found so far, turn out to be precisely those of the Moon model, we have the strongest suspicions that we are only re-discovering some of the paths which led Moon to the original construction. This, too, is exciting.

The mode of presentation for this report is not strictly pedagogical, but rather more like that of an experimental log, where the subject is the recent several-months-long shared effort. Much care has gone into the preparation of charts, and the working up of diagrams intended to make the constructions comprehensible to anyone who has mastered the Platonic solids and the elementary Moon model construction. (See "The Geometric Basis for the Periodicity of the Elements," 1988, www.21stcenturysciencetech.com.) Difficulties will arise, however, for those unfamiliar with the Ampère-Gauss electrodynamics. Rather than rework the substantial body of material involved therein, for purposes of this report, we refer the reader to the original work, and to my reports in the Fall 1996 *21st Century Science & Technology*, as introduced by Dr. Jonathan Tennenbaum in the editorial in the same issue.²

The entirety of Dr. Moon's thinking in nuclear physics was shaped by his understanding of the superiority of the electrodynamics of Ampère, Gauss, and Weber over the hegemonic

Faraday-Maxwell conceptions. Ampère's original experiments and the Gauss-Weber electrodynamics, with emphasis on Wilhelm Weber's 1871 paper,³ were the point of reference for any scientific discussion with Moon, as Stevens recalled from his first 1974 meeting with him in Chicago (which was followed, shortly thereafter, by a meeting with Lyndon LaRouche at which the same topic was at the center).

The special feature of the referenced 1871 paper of Weber lies in the influence of the Leibnizian current of thought, which was brought into Gauss's Göttingen University through the influence of Abraham Kaestner (1719-1800). Leibniz's concept of *monad* emerges in Weber's thought, among other locations, in the recognition of a minimal distance, ρ , below which the so-called Coulomb force of mutual repulsion of like particles reverses. (We shall discuss this further below in connection with the "Weber pair.") From this, emerges the proper concept of the atomic nucleus, the

2. Laurence Hecht and Jonathan Tennenbaum, "The Atomic Science Textbooks Don't Teach," *21st Century*, Fall 1996.

3. Wilhelm Weber, "Electrodynamic Measurements—Sixth Memoir, Relating Specially to the Principle of the Conservation of Energy," *Phil. Mag.*, S.4, Vol. 43, No. 283 (Jan. 1872), pp. 1-20 and 119-149.

	INERT GASES																													
	O																													
	1A											IIIA	IVA	VA	VIA	VIIIA	10													
1	1 H 1.00797											5 B 10.81	6 C 12.011	7 N 14.0067	8 O 15.9994	9 F 18.99840	10 He 4.00260													
2	3 Li 6.941	4 Be 9.01218											13 Al 26.98154	14 Si 28.086	15 P 30.97376	16 S 32.06	17 Cl 35.453	18 Ar 39.948												
3	11 Na 22.98977	12 Mg 24.305											19 K 39.098	20 Ca 40.08	21 Sc 44.9559	22 Ti 47.90	23 V 50.9414	24 Cr 51.996	25 Mn 54.9380	26 Fe 55.847	27 Co 58.9332	28 Ni 58.70	29 Cu 63.546	30 Zn 65.38	31 Ga 69.72	32 Ge 72.59	33 As 74.9216	34 Se 78.96	35 Br 79.904	36 Kr 83.80
4	19 K 39.098	20 Ca 40.08	21 Sc 44.9559	22 Ti 47.90	23 V 50.9414	24 Cr 51.996	25 Mn 54.9380	26 Fe 55.847	27 Co 58.9332	28 Ni 58.70	29 Cu 63.546	30 Zn 65.38	31 Ga 69.72	32 Ge 72.59	33 As 74.9216	34 Se 78.96	35 Br 79.904	36 Kr 83.80												
5	37 Rb 85.4678	38 Sr 87.62	39 Y 88.9059	40 Zr 91.22	41 Nb 92.9064	42 Mo 95.94	43 Tc 98	44 Ru 101.07	45 Rh 102.9055	46 Pd 106.4	47 Ag 107.868	48 Cd 112.40	49 In 114.82	50 Sn 118.610	51 Sb 121.75	52 Te 127.60	53 I 126.9045	54 Xe 131.29												
6	55 Cs 132.9054	56 Ba 137.34	57 *La 138.9055	72 Hf 178.49	73 Ta 180.9479	74 W 183.85	75 Re 186.207	76 Os 190.2	77 Ir 192.22	78 Pt 195.09	79 Au 196.9665	80 Hg 200.59	81 Tl 204.37	82 Pb 207.19	83 Bi 208.9804	84 Po (210)	85 At (210)	86 Rn (222)												
7	87 Fr (223)	88 Ra 226.0254	89 †Ac (227)	104 Ku	105 Ha	106																								

1 H 1.0079	Atomic number
	Atomic mass

58 Ce 140.12	59 Pr 140.9077	60 Nd 144.24	61 Pm (147)	62 Sm 150.4	63 Eu 151.96	64 Gd 157.25	65 Tb 158.9254	66 Dy 162.50	67 Ho 164.9304	68 Er 167.26	69 Tm 168.9342	70 Yb 173.04	71 Lu 174.97
---------------------------	-----------------------------	---------------------------	--------------------------	--------------------------	---------------------------	---------------------------	-----------------------------	---------------------------	-----------------------------	---------------------------	-----------------------------	---------------------------	---------------------------

90 Th 232.0381	91 Pa 231.0359	92 U 238.029	93 Np 237.0482	94 Pu (244)	95 Am (243)	96 Cm (247)	97 Bk (247)	98 Cf (251)	99 Es (254)	100 Fm (257)	101 Md (258)	102 No (255)	103 Lr (256)
-----------------------------	-----------------------------	---------------------------	-----------------------------	--------------------------	--------------------------	--------------------------	--------------------------	--------------------------	--------------------------	---------------------------	---------------------------	---------------------------	---------------------------

THE PERIODIC TABLE OF THE ELEMENTS

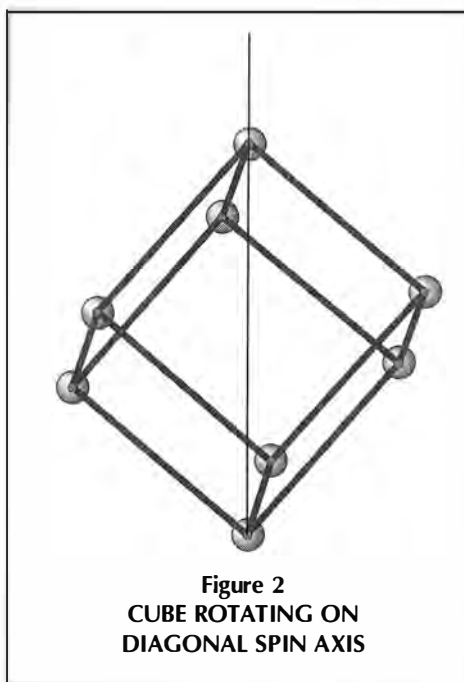
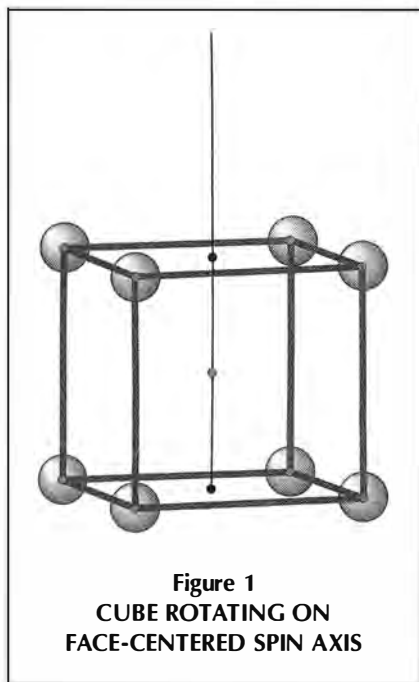

one which always informed Dr. Moon's thinking: a monad-like existence determined by a universal ordering principle, as distinct from the reductionist's absurdity of a self-existent elementary building block, the Aristotelian *protyle*, which has dominated most thinking on the subject of atomic physics for the past century.

Dr. Moon was one of the great experimental physicists of the century, a true genius, although of a very self-effacing character, who waged a stubborn, lonely fight for truth amidst a degenerating culture. An appreciation of the Ampère-Weber electrodynamics ran through all his work, from his first major experimental construction, the University of Chicago cyclotron, which he designed and built in 1935-1936 with a team of students from William Draper Harkins's physical chemistry department, to his last hypothesis, a half a century later, the Moon model of the nucleus. Whoever wishes to understand the Moon model in any depth, cannot avoid the pleasant and inviting challenge of mastering the original work of Ampère and Weber. It has been my hope that some new talents will soon take up this challenge, so that we might create a broader group of collaborators in this exciting work.

(1)
**A Spin Axis of the Nucleus;
Moment Arms and Isotopes**

This work began where I had left it about a year ago, in the examination of the possible placement of neutrons in the Moon nucleus, as it might bear on the singularities known as "magic numbers." The discovery, in the second decade of the 20th Century, of isotopic forms of the elements introduced a third dimension into the periodic table. New questions were now raised: Why do certain elements have a large number of naturally occurring isotopes, others very few, and others only

one? The experimental verification of Harkins's neutron in 1932 posed the same question in a new way: What determines the number of neutrons in each isotopic species? These questions are still unanswered. The symmetries of the Moon model offered the hope of finding a reason that Nature should favor configurations containing certain numbers of neutrons, and not others.

Early in the course of my recent re-examination, I introduced the hypothesis of an *axis of spin* for the nuclei. My previous investigation of neutron placement had considered the nucleus only from the standpoint of its spherical symmetry. I had thus assumed that the neutrons would fill the positions on the spherical shells of equal distance from the center, which are defined by unused faces and

edge midpoints of the solids whose vertices defined the position of the protons. By introducing a spin axis, an entirely new consideration came into play, that is, the distance of the nuclear particle from the axis.

Making the assumption that the preferred configurations would be those which minimize the angular momentum around that axis, it now became possible to examine the assortment of isotopes in a new light. A graphic example will best help to explain this.

Consider the cube representing the oxygen nucleus. First, consider an axis of spin passing through opposite face centers of the cube (Figure 1). Assuming the mass of the protons to be equal and localized at the vertex points, the moment of momentum of a proton is determined solely by its distance from the axis. For a cube whose edge is 1, the distance is $\sqrt{2}/2$. The total moment for the 8 protons is $4\sqrt{2} = 5.6569$.

We may compare the value just derived to the moment produced when the cube is spinning on an axis which passes through two diagonally opposite vertices (Figure 2). In this case, two vertices lie on the axis. For a cube of edge 1, the moment of momentum for each of the other six protons is $\sqrt{6}/3$, and the total moment $6 \times \sqrt{6}/3 = 4.88990$, considerably less than that for the face-centered spin axis.

However, we must also take into account the moments of the neutrons. In placing the neutrons, we had always assumed that they must be contained within the shells of the protons. For this and other reasons, we had assumed an inner tetrahedron, or "alpha particle," whose vertices would first serve as the locations for the two protons and two neutrons of the helium nucleus, while for nuclei of atomic number greater than 2, these would serve as the location for neutrons. We portray that from two points of view in Figure 3. Figure 3 (a) is the view looking down the diagonal axis of the cube. Two protons and a neutron lie on the axis, although these cover one another, so only one sphere is visible at the center of the right-hand figure.

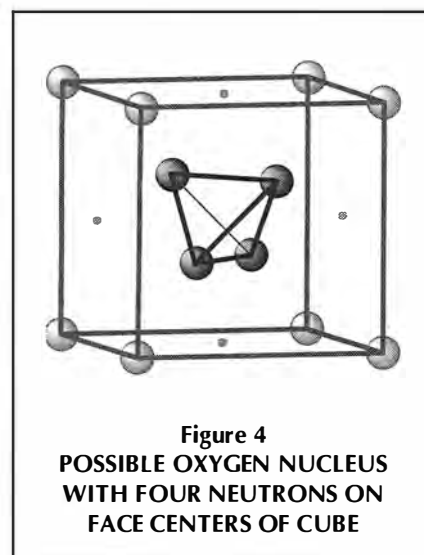
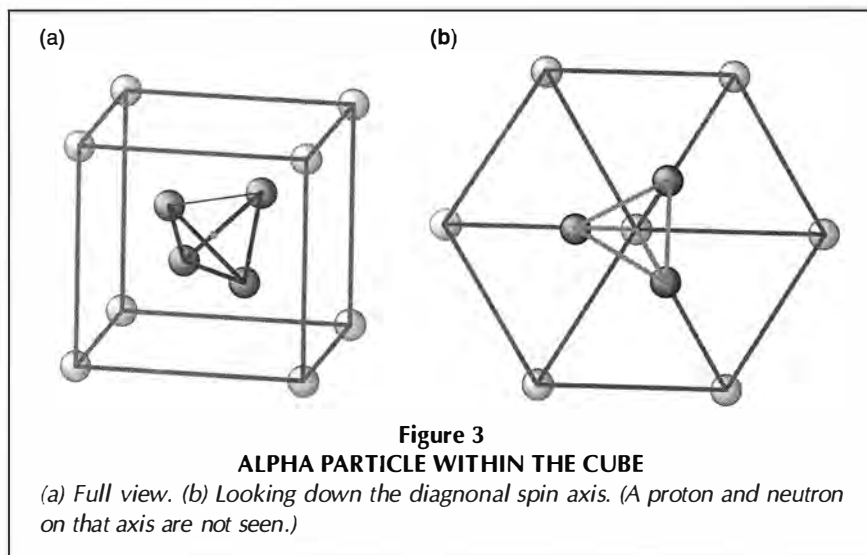

Here also, calculation of the moments on the tetrahedron shows that the favored configuration is that which spins on the diagonal axis of the cube.

Finally, we must consider the neutrons which lie on the cube. For oxygen, we assume four neutrons on the alpha particle, and four on the face centers, as pictured in Figure 4. The moments of certain neutron positions vary, depending on the axis chosen. The configuration of neutrons shown produces a minimum total moment for either spin axis. However, the total moment is least when the diagonal spin axis is chosen.

The concept of a spin axis for the nucleus seemed suggestive; however, there were many questions. Did the nucleus spin at all times, or only when subjected to external forces such as magnetism? How would its existence be manifested? We made some preliminary attempts to construct the first eight elements, calculating the moments for each principal isotope. There were many uncertainties. The first five elements contain many anomalous features. Why is lithium-7, with 3 protons and 4 neutrons the most abundant isotope? Why is 4-beryllium-9 stable, while beryllium-8 breaks up into two alpha particles? Why are 5-boron-10 and 7-nitrogen-14 odd-odd nuclei? We also examined the atomic numbers above oxygen. Here there were some more hints that the spin axis was a decisive feature determining why some isotopes occur and not others. But nothing was decisive.

(2) The 'Axis of the Universe'

One day, as I was examining a Plexiglas model of the Moon nuclear structure, I noticed that one pair of faces of the octahedron appeared to be parallel to the overlying faces of the icosahedron (Figure 5). If this were true, then a unique axis passing through the diagonal of the dodecahedron and the underlying face center of the dual icosahedron, would then pass through the face center of the underlying octahedron, and down the diagonal axis of the cube. A unique axis of the whole Moon model configuration would thus be determined.

We called it the "axis of the universe (Figure 6)."

True, or merely appearance? From his studies of Gauss's *Pentagramma Mirificum*, Stevens was able to readily verify the parallelism of the unique pair of faces. The reasoning, in brief, is this: The vertices of the octahedron in the Moon model configuration correspond, directionally, to the positions of vertices in the figure known as the compound of 20 octahedra. The vertices of this compound figure can be determined by the rotation of any of the five cubes whose vertices correspond to the vertices of a dodecahedron. The cube is rotated such that one pair of vertices remain fixed in the dodecahedral vertices. The cube carries with it its dual octahedron. The face centers of any octahedron in the compound figure will then lie under the vertices of the dual cube which carries it. As two of these cube vertices are fixed in the dodecahedron, the corresponding two face centers of the octahedron will lie under them, which is to say, under the vertices of the dodecahedron.

Now, let the dodecahedron in that construction, correspond to the circumscribing dodecahedron of the Moon model (Figure 6). Then, a unique pair of face centers of the octahedron of the Moon model will lie under two diagonally opposite vertices of the dodecahedron. Ergo, the axis of the universe is established, for a unique axis then passes through the vertices of dodecahedron and cube, and the face centers of octahedron and icosahedron!

A New View of Uranium

With the discovery of this axis, some new things now fell into place. A clearer picture of the twinned structure which describes the uranium nucleus was the first important result. Uranium, atomic number 92, is a singularity in the Moon structure, occurring where the twinned dodecahedra open on a hinge, and the hinge then breaks to produce a connection between only two protons. Moon had suggested that each of the two protons slightly interpenetrates the other structure. Stevens recognized that the twinned uranium nucleus would then line up on the axis of the universe, and that the two interpenetrating protons would likely position themselves at the

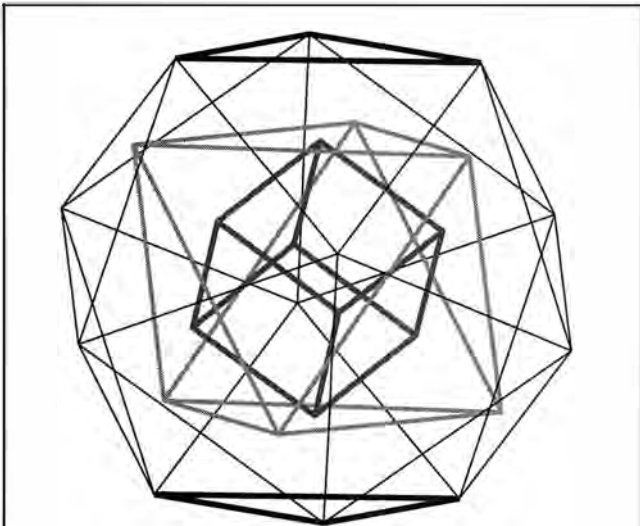

Figure 5
UNIQUE PAIR OF PARALLEL FACES OF
ICOSAHEDRON AND OCTAHEDRON
IN THE MOON MODEL

The faces of the icosahedron that are parallel to the octahedron are shown at top and bottom, emphasized by thick lines.

icosahedral face centers which lie under the dodecahedral vertex where they join. That would leave 73 neutron positions on each structure, precisely the correct number for the 146 neutrons of U-238.

Cube faces	6
Cube edges	12
Octahedral edges	12
Icosahedral edges	30
Icosahedral faces	13
Total	73

Secondly, our idea of minimal spin moments was reinforced. For the completed palladium nucleus, and for uranium, the "axis of the universe" forms the only symmetrical spin axis. Iron (the completed icosahedron) would have to spin on this axis, because the skew placement of the octahedron within the icosahedron could only be balanced when the unique pair of parallel faces was aligned perpendicular to the axis of spin. (See Figure 5.) The cube of oxygen, we had seen, would also prefer to spin on this axis, which coincides with the diagonal of the cube.

But silicon (the completed cube and octahedron) seemed to present a problem. From the standpoint of minimizing the angular moment, the axis of the octahedral "top" would be preferred. But this causes the inscribed cube to spin on its face-centered axis. If the minimization of angular moment were the only criterion, silicon would have to spin like a top on the diagonal axis of the octahedron. However, all the other completed structures of the Moon model followed the axis of the universe. A possible reason for this anomaly appeared when we examined the magnetic susceptibilities of the elements. Silicon is the only one of the completed Moon model structures to have a slight negative susceptibility (diamagnetism). The others are highly magnetic. We will discuss this further in Section 4.

The preference for the axis of the universe also suggested an explanation for two well-known curiosities of the periodic table: the argon-potassium anomaly and the apparent nuclear stability of tin. The shell model of the nucleus attempts to explain these two phenomena by the closing of assumed nuclear "shells" at 20 and 50. It is not convincing, to my mind. For, the shells may represent either neutrons or protons, sometimes both, and the presumed mechanism by which the stability operates (spin-orbit coupling) is a creation of dubious merit, which Maria Goeppert-Mayer adapted from the accepted model of the electron orbitals. The phenomenon called electron "spin," while representing something, is really not understood at all. It began as a hypothesized orbital motion, and ended as a piece of mathematical jug-

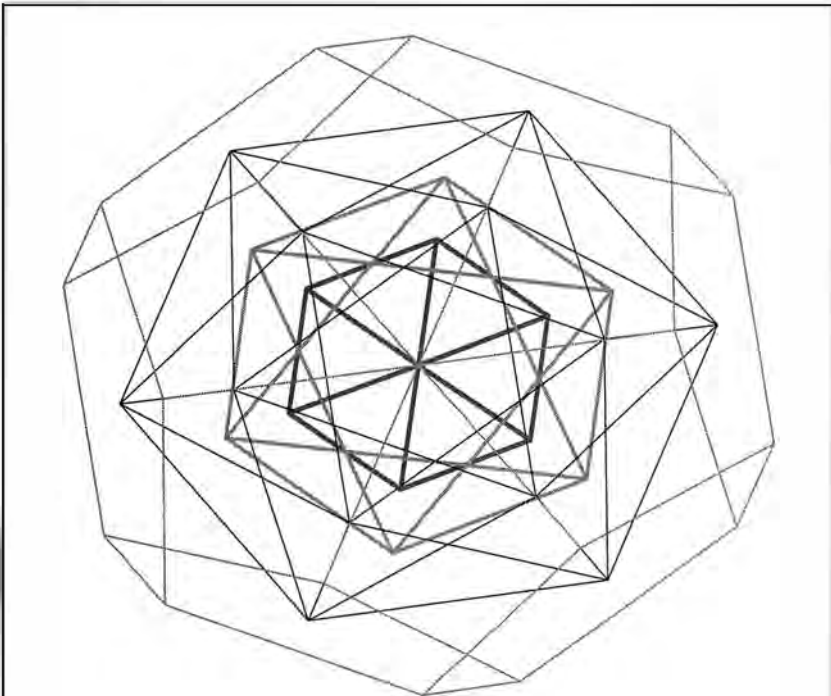

Figure 6
THE 'AXIS OF THE UNIVERSE'

The Moon model's "axis of the universe" passes through the center of this figure. It is a diagonal axis for the dodecahedron and cube, and a face-centered axis of the icosahedron and octahedron. The unique pair of parallel faces of the icosahedron and octahedron is seen head on. (Note the hexagonal quality of the four solids in this view.)

gling to fit the modified Bohr model.⁴

The Argon-Potassium Anomaly

For elements of low atomic number, there is a tendency for the number of neutrons to equal the number of protons, or to exceed the proton number by one. The first significant excursion from this pattern occurs at 18-argon-40 with 22 neutrons. However, potassium and calcium which follow, each have 20 neutrons. Calcium has 20 neutrons and 20 protons, making it "doubly magic."⁵ Calcium is highly abundant in the Earth's crust and the meteorite samples, and has six naturally occurring isotopes, considerably more than any preceding element.

Since Harkins' abundance has been associated with nuclear stability. From the Leibnizian standpoint of *transcreation*, all of the elements are being created all the time. But why some in preference to others?

The first three structures of greatest symmetry in the Moon model—the completed cube, octahedron, and icosahedron—correspond to the elements of greatest abundance in the solar system (oxygen, silicon, iron). The cases of calcium, and also tin, which is unique in having 10 naturally occurring isotopes, suggest how symmetries connected with the unique spin axis determine Nature's preference for these structures.

Let us look, first, at calcium. In the Moon model structure, 14 protons produce the completed cube and octahedron of silicon. Calcium requires six more protons on the icosahedron (Figure 7). We suppose these go on the unique pair of parallel faces which we have already described on the icosahedron. Once these faces are complete, the axis of the universe is determined as the spin axis. (This would probably occur first at 19-potassium when one triangular face is complete, and the other, two-thirds so.) Prior to that, there is no well-defined

Figure 7
20-CALCIUM-40
The last six protons of 20-calcium-40 form on the unique parallel faces of the icosahedron, allowing the structure to rotate on the axis of the universe (dotted line).

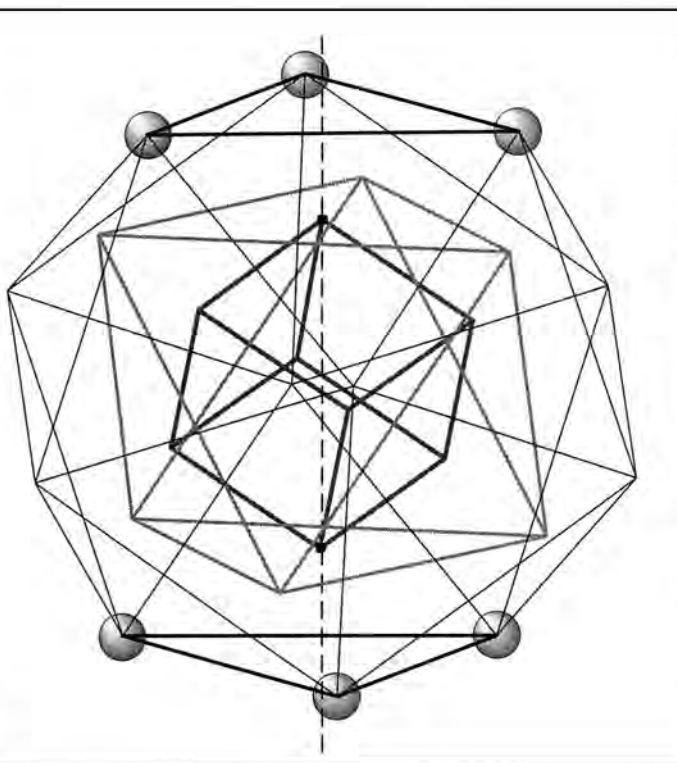

rotational axis. Argon is probably placing its 22 neutrons on the inner alpha particle (4), cube faces (6), and cube edges (12). Thus, all neutron locations are filled.

Tin, at atomic number 50, is unique in having 10 naturally occurring isotopes. Only two other elements have as many as 8. This has long been considered a sign of the unusual stability of tin's nucleus with 50 protons, and 50 is a magic number. The Moon model, considered in connection with the axis of the universe, gives a clear suggestion as to why: Palladium, at 46 protons, is the completed dodecahedron. To go beyond this, the structure must build a "twin," starting on one of the pentagonal faces of the dodecahedron. Yet, once that twinning occurs, there can no longer be a symmetrical spin around the axis of the universe. Tin solves this problem by placing one of the four additional protons on the axis of the universe, and the other three on adjacent vertices. The whole structure (Figure 8) may then spin on the axis of the universe, just as palladium does. This explains the unusual stability of the tin nucleus.

The next nucleus, 51-antimony, is unable to maintain this symmetry (Figure 9). It must place the five protons beyond palladium around a pentagonal face of the dodecahedron. At this point, the twinned structure is truly determined, but the axis of the universe can no longer provide a stable spin axis.

We pursued this idea of minimizing the spin moment around the axis of the universe, thinking we might be able to build the nuclei around this concept. Stevens calculated a table of moments for all the possible positions in the Moon model, and began attempting to construct the nuclei on the assumption of minimizing total moment. But some problems arose. There were things that didn't "fit." The light nuclei, such as lithium, beryllium, and boron, left us with uncertainties, as did the more complex nuclei that were not symmetric around this axis.

4. Maria Goeppert-Mayer had been a Göttingen student of Dr. Moon's close friend at Chicago, physical chemist James Franck, a German-Jewish refugee. Under Franck and Moon's influence at Argonne National Laboratory, just after World War II, Goeppert-Mayer began an investigation of the anomalies of the periodic table, which she usefully grouped, in a 1948 paper, under a concept of nuclear shells. According to biographical accounts, it was Fermi who suggested the bad idea of explaining the phenomena by the mechanism of spin-orbit coupling. Goeppert-Mayer received the Nobel Prize in 1958 for her elaboration of this mechanism.

5. The term "magic numbers" originated as a sly bit of humor by the physicists, intended to debunk attempts such as those of Harkins, Elsassner, and Goeppert-Mayer to discover a lawfulness in the properties of the elements constituting the periodic table. But the joke is on the physicists, for it is their belief in the magic efficacy of blackboard formulations which has proven to be useless in understanding the nucleus.

Figure 8
STABILITY OF THE
'MAGIC NUMBER'
50, IN THE MOON
MODEL

Tin, atomic number 50, requires four protons beyond the completed palladium core. One of these can form above the "axis of the universe," and the other three above the three nearest vertices of the dodecahedron. The structure then spins symmetrically about the axis.

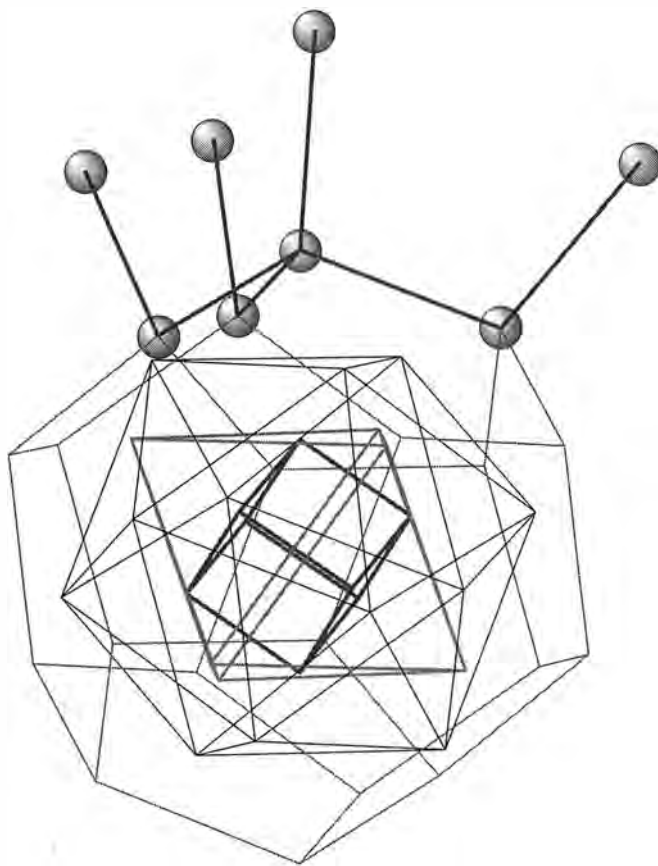

(3)

Concept of the 'Weber Pair'; Hypothesis of the Neutron; Attempt to Describe Mass Defect from the Nuclear Geometry; The Ontological Question

While Stevens was pursuing that path, I went back to the consideration of the structure I called the "Weber pair." This is the unique state of stable aggregation between two particles of like charge, whose existence Weber established in his 1871 memoir (cf. note 3), occurring below a minimal distance that Weber defined as ρ .

Employing modern determinations for the values of the charge in electrostatic units (e), the proton mass (m_p) and the velocity of light (c), the value of ρ for two protons is equal to $2e^2/m_p c^2$, or approximately 3×10^{-16} cm. Within a sphere of this tiny diameter, two positive nuclear charges will attract. Weber shows in the referenced paper (Section 8 ff.), that two such like charges would maintain a stable state of molecular aggregation in an oscillating motion along a straight line connecting them. The particles would accelerate toward the center of the line connecting them, approaching the velocity c , pass through one another, and decelerate to zero velocity

upon reaching the circumference of the sphere of 3×10^{-16} cm diameter, at which point they would again be attracted toward each other. I call this the Weber pair.

I returned to a hypothesis I had pursued earlier,⁶ that the Weber pairs would be placed along the diagonal axes of the Platonic solids comprising the Moon model. That is, instead of conceiving of each vertex as the position of a fixed proton, think of any pair of diagonally opposite vertices as the end points of a very short line along which the charge oscillates at extremely high frequency, according to the equation of motion described by Weber.

Many fruitful speculations followed. Among the most interesting was a new conception of the neutron. A moving charge will create around itself a circular magnetic field (to use the Faraday conception) whose strength would increase with velocity. Thus, an electron finding

itself in the vicinity of a Weber pair proton, would be pulled into a spiralling orbit around and along the path of the Weber pair. As the field increases with the velocity of the proton, the electron would be drawn in closer, such that the spiral would look like a corkscrew or pig's tail, which tightened as the charges moved toward the center.

A special sort of singularity must occur at the center of the Weber pair. The protons, moving at relative velocity $\sqrt{2}c$, must meet and pass through each other. The nuclear electron is then pulled in closest in its corkscrew orbit. I supposed that this is the point at which the neutron is created. Pulled into a very close orbit, the electron unites with the proton to form a neutral particle. Harkins's conception of the neutron (as Moon often recounted it), as an electron condensed on a proton, seemed to come to life.

If the proton thus turns into a neutron, one might ask how then there can be at least an equal number of protons and neutrons in the nuclei beyond hydrogen? The answer comes when we recognize that with the Weber pair, we are dealing with what today are called relativistic velocities (and at the singularity, a *superluminal* velocity). In the conventional view, there will be what Special Relativity sees as a relativistic mass increase sufficient to double the apparent mass of the proton. The quantification of this in accordance with known formulations is not possible, because we are in a new regime of particles accelerating to superluminal relative velocities. Weber's original formulation of the relativistic Fundamental Electrical Law, in which

6. Laurence Hecht, "Advances in Developing the Moon Nuclear Model," *21st Century*, Fall 2000, pp. 5-12.

it is the change in force between charges, and not their mass, which varies with relative velocity, does not easily resolve the difficulty. Thus, rather than a formal mathematical analysis, I sought to examine geometrically the probable bounding conditions of the process.

The first thing I noticed was that the conjectured neutron would appear in a circular orbit in a plane perpendicular to the center of the axis of the Weber pair. The neutrons could thus be thought of as circular hoops oriented perpendicular to these axes, which are the axes of the Platonic solids (cf. note 6). Thus, a sequence of cyclic solids would be created as protons were placed on the Moon model structure. First, four hoops for the four axes of the cube, producing the cuboctahedron of 12 vertices where the hoops intersect; then three hoops for the three axes of the octahedron, producing an octahedron of 6 vertices; then six hoops for the six axes of the icosahedron, producing the icosadodecahedron of 30 vertices. If, in some way, the intersections of these hoops representing neutron orbits, might correspond to the creation of additional neutrons, there would then be a correspondence to the hypothesized neutron placements I had arrived at many years ago in considering the Archimedean solids.

Mass Defect As a Geometric Property of the Nucleus

This speculation concerning the neutron now led in another direction, to the consideration of mass defect. Mass defect is a concept that arose in the early stages of atomic physics. Calculations based on the deflection of particles in a field and the energy balance of particle collisions had led to precise measurements of the presumed mass of the proton, neutron, and electron. The atomic hypothesis assumes that the weight of the elements should equal the sum of these constituent parts. However, when the calculated mass of each element was compared to the measured atomic weight, a discrepancy was found which came to be known as the *mass defect*. The hegemony over physics of the Aristotelian notion of *energeia*, as opposed to the Platonic concept of power (*dynamis*), led to the explanation that the mass defect arises from the so-called *binding energy*; that is, the missing mass is used up in the form of the energy needed to hold the nucleons together. Einstein's equation for energy-mass equivalence can predict, from the mass defect, the amount of energy (actually, work) which will be produced by a nuclear reaction.

The poorly trained physicist searches, in vain, for a defini-

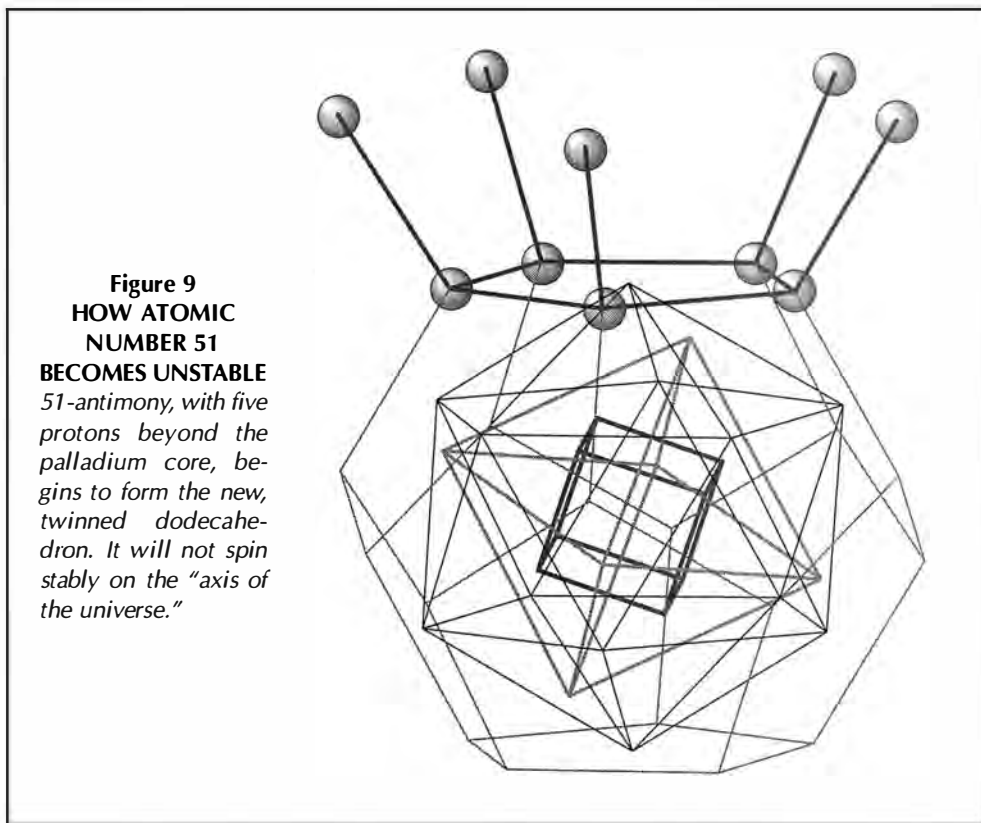

Figure 9
HOW ATOMIC
NUMBER 51
BECOMES UNSTABLE
51-antimony, with five protons beyond the palladium core, begins to form the new, twinned dodecahedron. It will not spin stably on the "axis of the universe."

tional distinction between *energeia* and *dynamis*. "How does it change my formula?" he asks. What is missing is the concept. By invoking the equivalence of energy and mass to explain an anomaly in the periodic table, one is only displacing the problem to another realm. Why is energy equivalent to mass?

I supposed that the reason for mass defect would be found in the geometry of orientation of the Weber pairs. As I have many times noted, the 1846 Weber formulation for the Fundamental Electrical Law (which first appeared in Gauss's *Notebooks* in 1835), is strictly relativistic. When stated in the simpler form of his Law of Potential, Weber's electrostatics shows that the work done by one electrical particle upon another is dependent upon their relative velocities. The well-known formula derived from Special Relativity, $E = mc^2$, merely amounts to a restatement of Weber's law, interpreted in such a way that the mass, rather than the force between particles, changes with relative velocity. As Franklin D. Roosevelt's chief wartime science adviser, Vannevar Bush, noted in his 1926 defense of the Weber electrostatics, what is measured in experiments on moving electrons is not the *mass*, but the *charge-to-mass ratio*.⁷ Thus, any experiment which purports to show a mass increase, as predicted by Special Relativity theory, can equally well be interpreted as evidence of a charge decrease; that is, a decrease in the measured force between particles, precisely the result one expects from the Gauss-Weber formulation.

Weber's formula describes the relation for the pair-wise

7. V. Bush, "The Force between Moving Charges," *Jour. Math., and Phys.*, Vol. V, No. 3 (March 1926).

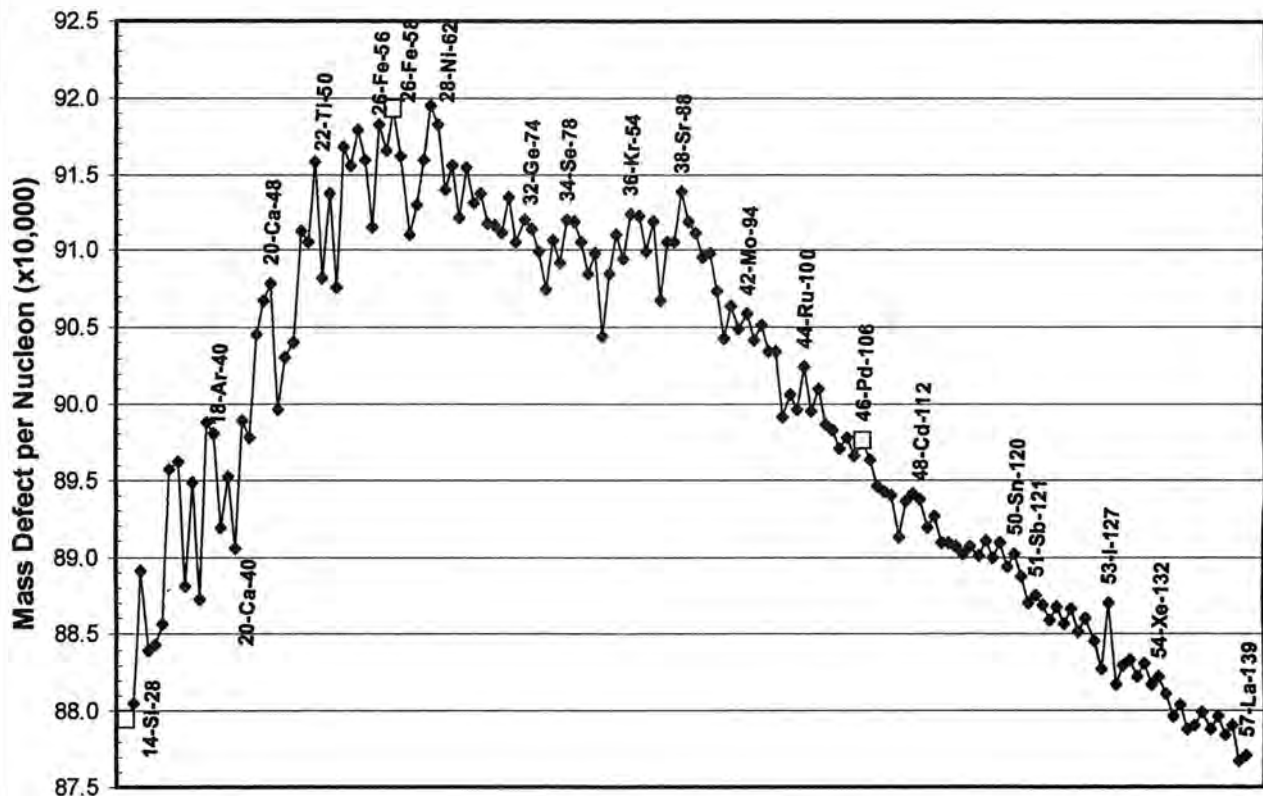

Graph 1
MASS DEFECT PER NUCLEON OF NATURAL ISOTOPES FROM Si-28 TO La-139

Source: Calculations based on data from *Handbook of Chemistry and Physics*, Boca Raton, Fla.: CRC Press, 60th Edition (1980), pp. B-236 to B-274.

interaction of electrical particles. I hypothesized that in the nucleus, these Weber pairs would be oriented toward the vertices of the Platonic solids of the Moon model. The differing geometries would produce different charge effects, and therefore varying apparent masses of the nuclei.

On getting into such considerations, one recognizes that mass or gravitation, as Riemann and Weber suspected, must be an electrodynamic phenomenon. The orientation and relative motions of charges within the nuclei of attracting bodies are the source of what is called the gravitational "force." That means that when we weigh something, we are actually measuring an electrical attraction between the very rapidly moving charges of the Weber pairs.

The mathematical treatment of the interactions among the moving charges of the Weber pairs raises difficulties of even greater complexity than the insoluble n-body problem in gravitation. I wondered if the problem could be approached by looking at the geometry of the Moon model. To do so, I calculated and graphed the mass defect per nucleon for all the naturally occurring isotopes through 57-Lanthanum-139, wondering if I would find unusual values at the Moon model singularities. In this, I was partly disappointed. The graph of mass defect per nucleon (Graph 1) is essentially the same as the well-known curve of binding energy. It rises to a peak at iron through nickel, and then declines. There is nothing particular-

ly notable about the values for oxygen, silicon, or palladium.

Nonetheless, the peak at iron is significant. There is no conventional explanation for it, but iron is one of the singularities of the Moon model. I believe it was at this point that I began to think of magnetism in connection with the Moon model.

The Ontological Question, Briefly

Before closing on the subject of mass defect, we will make a brief but necessary mention of the ontological question implied. Any truthful explanation of this singular phenomenon will require an overturning of generally accepted empiricist assumptions respecting "mass." What modern scientific thought takes as the most self-evident of qualities is, in truth, the most interesting of all ambiguities. One could summarize the failure of modern, generally accepted approaches in these few words: What should be the subject of investigation is assumed as already known. To proceed in this matter from any lesser ontological standpoint than that of Plato, Cusa, and Leibniz is foolery. The history of the subject shows that the fundamental breakthroughs occurred precisely where that standpoint was taken up and empiricist notions rejected.

Modern physical chemistry began with Antoine Lavoisier's adoption of the program laid out by Nicholas of Cusa in the "De Staticis" (On Statics) section of his *De Idiota Mente* (The

Layman on Mind): the application of the precision balance to the investigation of what we now call chemical and biochemical processes. Mendeleev's discovery of the periodic property of the elements required an explicit overturning of the Galileo-Newton assumption respecting mass, as he noted in the 1889 Faraday lecture:

The primary conception of the masses of bodies, or of the masses of atoms, belongs to a category which the present state of science forbids us to discuss, because as yet we have no means of dissecting or analyzing the conception. All that was known of functions dependent on masses derived its origin from Galileo and Newton, and indicated that such functions either decrease or increase with the increase of mass, like the attraction of celestial bodies. The numerical expression of the phenomena was always found to be proportional to the mass, and in no case was an increase of mass followed by a recurrence of properties such as is disclosed by the periodic law of the elements. This constituted such a novelty in the study of the phenomena of nature that, although it did not lift the veil which conceals the true conception of mass, it nevertheless indicated that the explanation of that conception must be searched for in the masses of the atoms; the more so as all masses are nothing but aggregations, or additions, of chemical atoms which would be best described as chemical individuals.⁸

Bernhard Riemann's conception of the *geistesmasse*, as developed in the "Philosophical Fragments,"⁹ is the most far-reaching of approaches taken by modern mathematical physicists. Riemann and Wilhelm Weber's attempts to derive the electrodynamic origin of mass (gravitation) bear on this matter. Our explorations of the Moon model suggest that atomic weight and mass defect are expressions of the geometry of the nucleus. A clearer understanding of the Moon nucleus will thus shed light on this important question.

(4)

Magnetism As a Periodic, Nuclear Property; Curie and Langevin's Theory; Our Theory; Where Is the Electron? Palladium and the Great Harmony; Magnetism of the Lanthanides; The Self-sustaining Cube; Gadolinium.

In thinking about properties which correlate to the singularities of the Moon model, my thoughts turned to magnetism. I recalled that Harkins had remarked on the strong paramagnetic susceptibility of oxygen and palladium. What we call *para-*

magnetism today was called *weak magnetism* by Pierre Curie, who systematically studied the magnetic properties of the elements. His work is summarized in an 1895 paper, one of the great works of physical chemistry, which remains a classic in the study of magnetism.¹⁰ Curie discovered that the weakly and strongly magnetic substances shared the property that on heating, they lost their attraction to a magnet. Some elements fell into another category, the *diamagnetic*. These substances are repelled by either pole of a magnet, but much more weakly than the paramagnetic substances are attracted. Diamagnetism does not weaken with heating, with the one exception of the element bismuth, which is the most strongly diamagnetic.

A systematic study of diamagnetism had been carried out by Weber, using metallic bismuth. Weber proposed that diamagnetism is the result of induced molecular currents. Recall that Weber was a follower of Ampère, who had proposed that magnetism is the result of the presence of *molecular currents*, by which he meant resistance-free circuits surrounding what we today call the atom. On bringing a magnet into the vicinity of a substance, Weber supposed that an Ampère molecular current was induced. By the laws of induction of Nobili, Neumann, and Lenz, the which Weber had systematized under his Fundamental Law of Electrical Action, the magnetism produced by the induced current must be such as to oppose the motion of the inducing magnet. Else, as Weber noted, a small amount of work in the motion of the inducing magnet would be multiplied indefinitely. Hence the repelling force of diamagnetism.

Weber thus hypothesized that diamagnetism was a natural property of all substances. Magnetism had to be the result of some special configuration of the inner parts which masked the natural diamagnetism. Curie's hard-won discovery that the magnetic property dissipated upon heating, tended to confirm the Ampère-Weber view of magnetism, which became generally accepted, even as their conception of electrodynamics was replaced by the Faraday-Maxwell formalism. Paul Langevin, a younger colleague of Curie, first proposed a systematic theory of electron orbitals as the cause of the magnetic property. In a 1905 paper,¹¹ Langevin drew on Curie's work on symmetries, which had characterized the magnetic field as possessing the symmetry of the cylinder. Langevin suggested that the electron orbitals in magnetic and paramagnetic substances must somehow arrange themselves such as to produce an overall cylindrical conformation, such that the currents act together like a solenoid. The diamagnetic substances, on the other hand, would possess a greater symmetry, such that an inducing field would not be able to orient the atom in any particular direction. From whatever direction the magnetic pole approached, it would induce a current in the electron orbitals which would oppose it. Langevin

8. "The Periodic Law of the Chemical Elements," by Professor Mendeléeff, Faraday Lecture Delivered before the Fellows of the Chemical Society in the Theatre of the Royal Institution on Tuesday, June 4, 1889. In D. Mendeléeff, *The Principles of Chemistry*, Third English Edition (London: Longmans, Green, and Co., 1905) and (New York: Kraus Reprint Co., 1969), Vol. II, p. 494).

9. The first English translation of Riemann's "Philosophical Fragments" appears in the Winter 1995-1996 issue of *21st Century*, pp. 50-62.

10. M.P. Curie "Propriétés magnétiques des corps à diverses températures" (Magnetic Properties of Bodies at Different Temperatures), *Annales de Chimie et de Physique*, Juillet (July) 1895, pp. 289-405.

11. P. Langevin, "Magnétisme et théorie des électrons" (Magnetism and the Theory of Electrons), *Annales de Chim. et de Phys.*, Vol. 8 (1905), pp. 70-127.

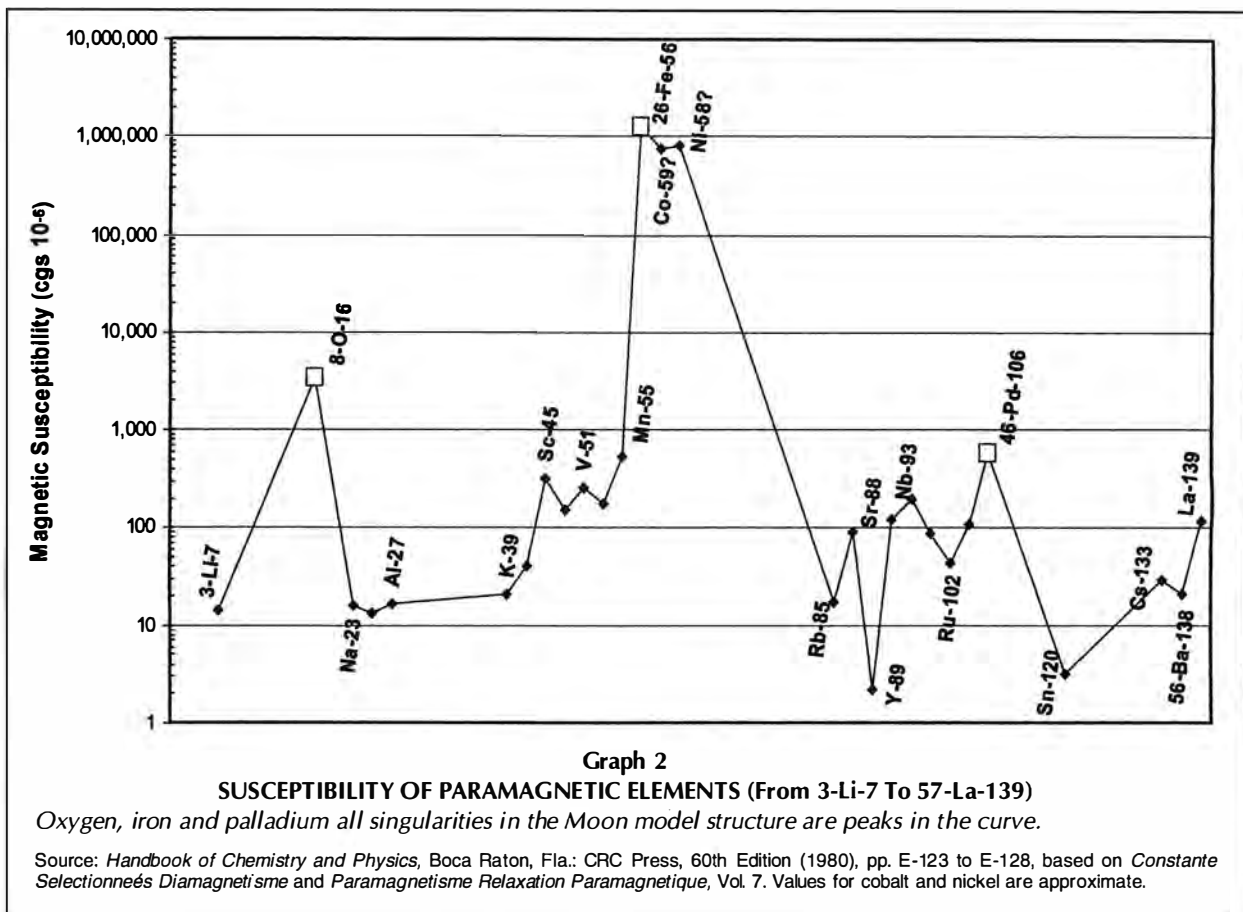

explained the gradual disappearance of the magnetic property with heat, by supposing that the thermal agitation of the atoms tended to give them a random orientation which eventually overcame the alignment produced by the cylindrical arrangement.

Langevin's is a masterful work of mathematical-physics hypothesis, and well ahead of its time, the properties of the electron having barely been established at the time of writing. I found the paper a useful sounding board for my own ideas on the subject, which I was developing at the same time as I was reading it. Yet, like most of modern physics, it was too pat. Something was missing. In the end, I could not disagree with the conception of a cylindrical symmetry to the electron motions. The correspondence of high magnetic susceptibilities with the Moon model singularities, where one finds the highest spherical symmetry, seemed to go against Langevin's fundamental premise of a cylindrical symmetry. The paradox was resolved when we considered the spin of the nucleus around the unique axis we had identified. The magnetism is then not the result of simple orbital motions of the electrons, but of the transport of the electron, orbit and all, by the nuclear spin. Stevens and I came to this conclusion as we examined the geometric properties of the Moon model at the singularities where magnetic susceptibility is a maximum.

The first step was to assemble a table of the susceptibilities of all the elements. I show this data in a variety of graphic forms. In Graph 2, I show the susceptibility of the para-

magnetic elements from 3-lithium-7 to 57-lanthanum-139. Note that the y-axis is on a logarithmic scale. The extraordinary magnetism of the Moon model singularities at 8-oxygen and 46-palladium stand out, and of course 26-iron. (Cobalt and nickel are nearly as magnetic as iron; the question marks are there on the chart because I lack exact values for them.) Graph 3 shows the susceptibilities of the diamagnetic elements from helium to bismuth. Silicon, which represents the completed octahedron of the Moon model, is diamagnetic, although only very slightly so. This was an anomaly to be explained.

Our Theory of Magnetism

The concept of magnetism we developed was based on the observation that the Moon model representations of the nuclei of oxygen, iron, and palladium, are precisely those which we discovered to rotate with perfect symmetry around the axis of the universe. Silicon, which shows a slight diamagnetism, will not minimize the mechanical moment of momentum of the nucleons when spinning on the axis of the universe, as we showed in Section 2. It prefers the "top" axis of the octahedron.

However, if it is not the motion of the nuclear charges, but the extra-nuclear electrons which are producing the magnetism (although even this assumption must be carefully examined), one must break through one of the great barriers of contemporary nuclear physics, and propose a causal relationship

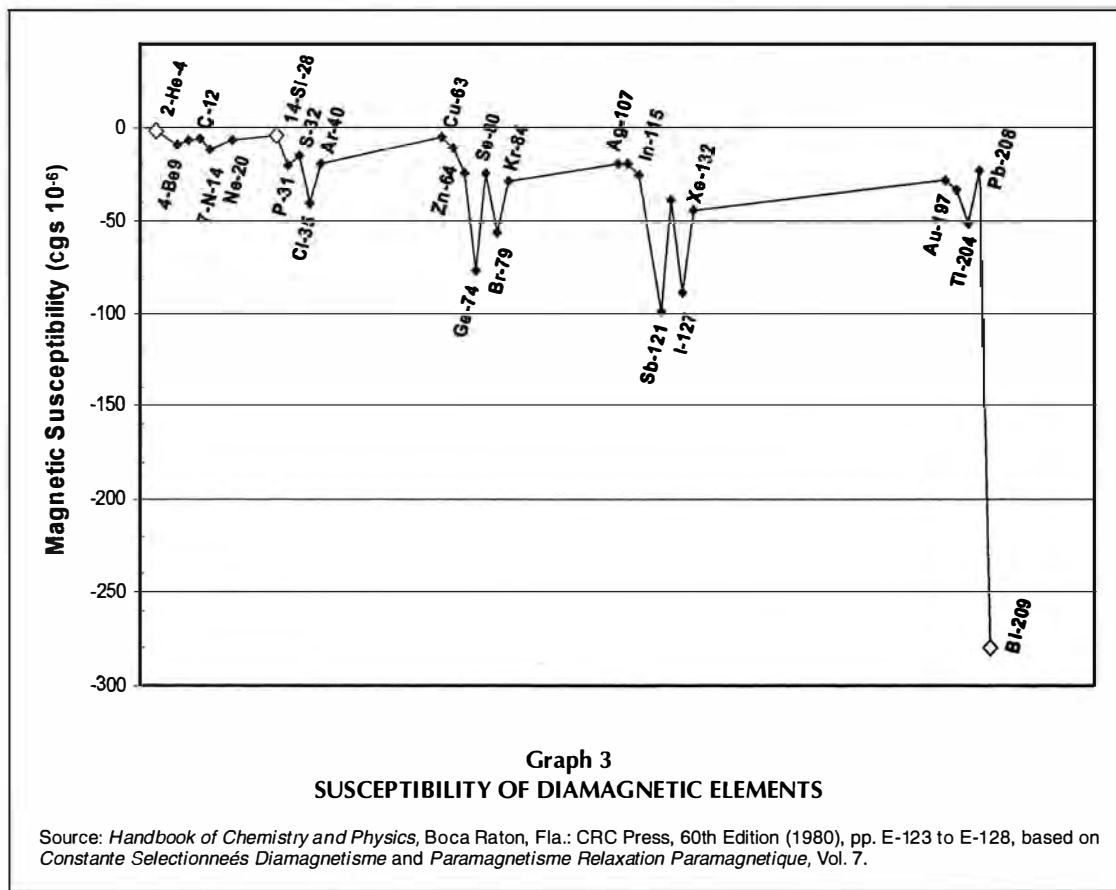

between the nuclear geometry and the arrangement of electron orbitals, in order to establish a relationship between the nuclear motion and magnetism. In proposing that magnetism derives from a nuclear property, we may also seem to be defying the widely held belief, which goes back to Langevin's 1905 paper, that the disappearance of magnetism with heat is caused by thermal agitation of the atom. It is generally thought that nuclear properties do not respond to mechanical action such as heat. Yet must not the nucleus be involved?

Where Is the Electron?

In connection with the concept of the neutron, described in Section 3, I had also conceived of a corkscrew-like extra-nuclear electron orbital, parallel to, but much larger than the paths traced by the nuclear electrons which are captured to become neutrons. The extra-nuclear electrons would follow spiral orbits around the Weber pair, but at a distance about 1,000 times farther out. For the same reason as the nuclear electrons, these orbits would tighten as they approach the center, converging like two opposed corkscrews. These electrons would then have opposing spin. As the charge density of the protons on the Weber pair is greatest at the center, because of their high velocity there, the electrons would also have greatest charge density around the center. For purposes of rough calculation, one could then simplify the electron spiral, into a circular orbit moving in a plane which is perpendicular to the Weber pair, and close to the center of the pair. If the angular velocity of the nuclear spin is high in

comparison to the orbital velocity of the electron in this reduced circular orbit, then it is not the orbital velocity of the electron, but the rotational velocity of the whole orbit which would act like the moving charge which produces the Ampère molecular current.

Weber's 1871 paper defines a stable state of aggregation of two unlike particles, in which the less massive particle revolves in a circular orbit around the more massive one. The radius of the stable orbit must fall within a minimal distance, ρ , determined in the same way as for the Weber proton pairs.¹² The radius of the electron orbit, so determined, comes to be 918 times greater than that of the Weber proton pair. Assuming that the electron orbital is conveyed with the spin of the nucleus, the velocity of the electron orbit would be considerably greater than that of the proton spinning much closer in to the center. Thus it would be the motion of the electron that is primarily responsible for the magnetism. The total magnetic moment would be a geometric sum of the electron and proton motions.

Suffice it to say that our supposition is entirely at odds with contemporary accepted views of magnetism. We attribute the magnetic moment to a collective motion of all the electron

12. The minimal distance, ρ , is equal to $[(e'e')/c^2] [(\epsilon + \epsilon')/\epsilon\epsilon']$, where e and e' are the charges of the two particles, ϵ and ϵ' their masses, and c is the Weber constant equal to $\sqrt{2}$ times the velocity of light. Taking the proton-electron mass ratio as 1,837, the value of ρ for the electron-proton pair will be 918 times greater than that for the proton-proton pair.

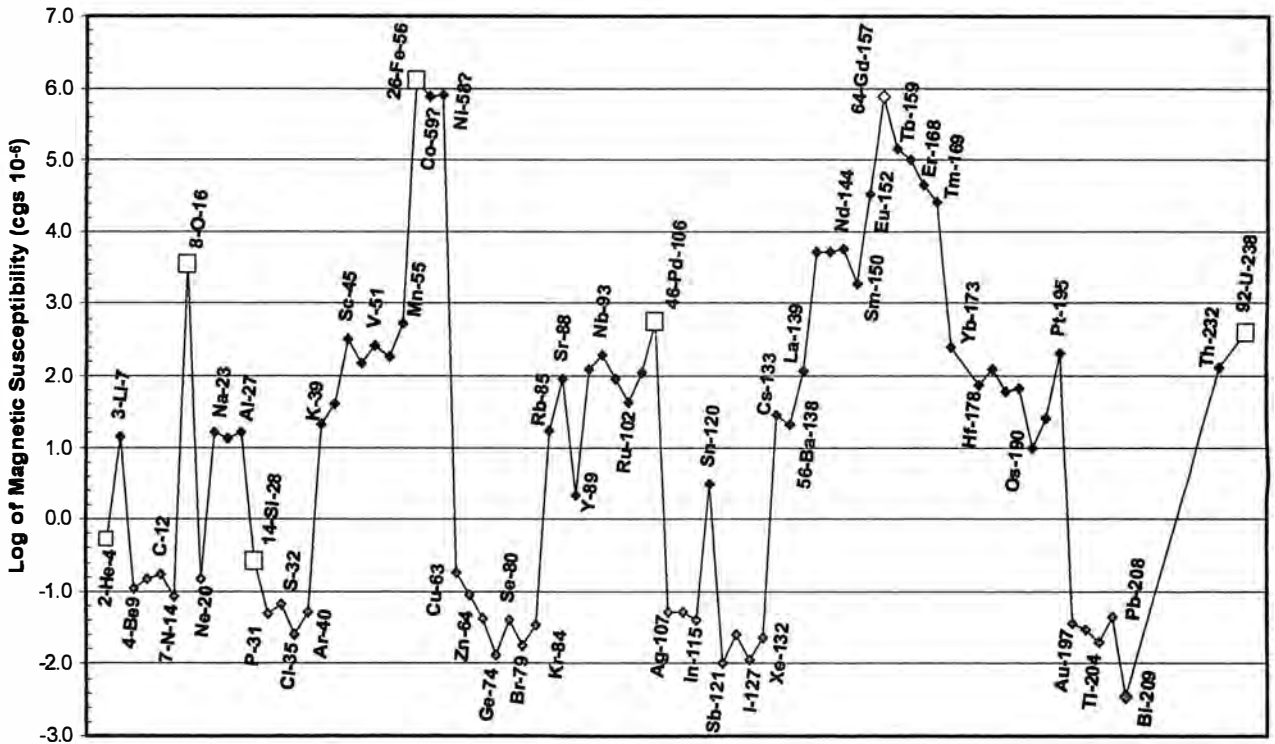

Graph 4
LOG OF MAGNETIC SUSCEPTIBILITY (2-He-4 to 92-U-238)

Source: *Handbook of Chemistry and Physics*, Boca Raton, Fla.: CRC Press, 60th Edition (1980), pp. E-123 to E-128, based on *Constante Selectionnées Diamagnetisme and Paramagnetisme Relaxation Paramagnetique*, Vol. 7. Values for cobalt and nickel are approximate.

orbitals, conveyed by the unidirectional spin of the nucleus. The accepted view attributes magnetism to the spin of certain extra-nuclear electrons. But that is not all, for our picture of the nucleus is so far different from the accepted picture (actually, there is no accepted picture) as to make any comparison impossible. The trained specialist recognizes immediately that if we are right, the whole edifice of 20th Century atomic physics must be rethought, as Dr. Moon had done. Moon was able to make breakthroughs where others could not, in part because he had a hands-on mastery of the crucial experiments on which the theoretical structure was built. He had done the experiments. Few of his peers had the combination of competence and courage to think in the same way. Today, the problem is far worse.

Palladium and the Great Harmony

There remained some internal inconsistencies in our hypothesis. For example, why is not the completed dodecahedron of palladium a stronger magnetic substance than iron? It carries more charges, and spins around the same unique axis. For another thing, how do we explain the high magnetic susceptibility of the lanthanide elements? In Graph 4, we show the available values for the magnetic susceptibilities of all the elements. The Moon model singularities are shown as squares. They all represent local maxima. But we also see here the high

susceptibility of the lanthanides, of which 64-gadolinium-157 is the peak.

In examining these paradoxes, some new geometric features of the Moon model became evident. Respecting palladium, we discovered that it is the first of the structures to have a shared axis. One axis of the cube and one axis of the dodecahedron line up along the axis of the universe. This produces a very curious dynamic for the two Weber pairs which share the same axis. By Stevens's analysis, the inner and outer protons will change places as the oscillation continues—palladium is a curious element.

In following this line of reasoning, one comes to recognize a great harmonic motion in the oscillations of the Weber pairs making up the more complex nuclei. Calculation shows the frequencies of these oscillations to be higher than any known radiation. The size of the nucleus also comes into question here. By the logic of the Weber electrodynamics, an increase in the number of Weber pairs would increase the attraction, causing the heavier nuclei to be smaller than the lighter ones, a conclusion which Dr. Moon frequently referred to. Yet there would be differing radii for the pairs arranged along the axes of the successive, nested solids. Some charges would have longer to travel than others. What is the sequence of their oscillations? Do all come to the center at once, or is there a kind of firing order?

Another item of overlooked significance, which is seen in Graph 4, "Log of Magnetic Susceptibility," is the periodicity of magnetism. Look at the values of magnetic susceptibility for the noble gases, Ne, Ar, Kr, and Xe. Look then at the values for the alkalis, Li, Na, K, Rb, and Cs. The Mendeleev periodicity and the Moon model periodicity are evident in the same graphic presentation. A still unsolved paradox lies here.

Magnetism of the Lanthanides

Our search for an explanation of the high magnetic susceptibility of the lanthanides also proved fruitful, and led us to a new understanding of the orientation of the Weber pairs. While I was assembling the data on magnetic susceptibilities, I suggested to Stevens that he try to figure out the reason for the magnetism of the lanthanides, and especially the very high magnetic susceptibility of gadolinium. One day he called with a partially formed idea, which involved returning to Dr. Moon's original construction for the lanthanides, a construction which I had slightly varied, thinking it would better explain the placement of neutrons. We got together that day, and came up with an explanation for gadolinium as well as a new insight into why the charges must orient to the axes of the Platonic solids.

The first time I saw Dr. Moon present his idea of the nucleus, using a model constructed out of used aluminum printing plates, his explanation for the anomaly of the lanthanides stood out in my mind. The 14 elements which share the same chemical properties as lanthanum, usually shown in a separate row at the bottom of the periodic table, had a reason for existing! In the building of the twin dodecahedron after palladium, the first 10 protons, which bring us to 56-barium, form the scaffolding of the new dodecahedron with a structure that looks like a scalloped salad bowl (Figure 10). At that point, the cube and octahedron build inside, forming the 14 lanthanides.

Recently, in trying to understand the continued reappearance of the "magic number" of 82 neutrons from barium through the first four lanthanides, I had hypothesized a rather complicated variation on Moon's construction, in which five vertices of the dodecahedron and five vertices of the icosahedron were the first to form. Stevens's insistence on the "salad bowl" in his still partial attempt to explain gadolinium caused me to wonder. In a joint session one afternoon, several long-standing problems were solved at once.

The Self-Sustaining Cube

In Ampère's original statement of the law for the force between current elements, upon which the work of Carl Friedrich Gauss and Wilhelm Weber immediately rested, there appears an angular term by which the inverse square

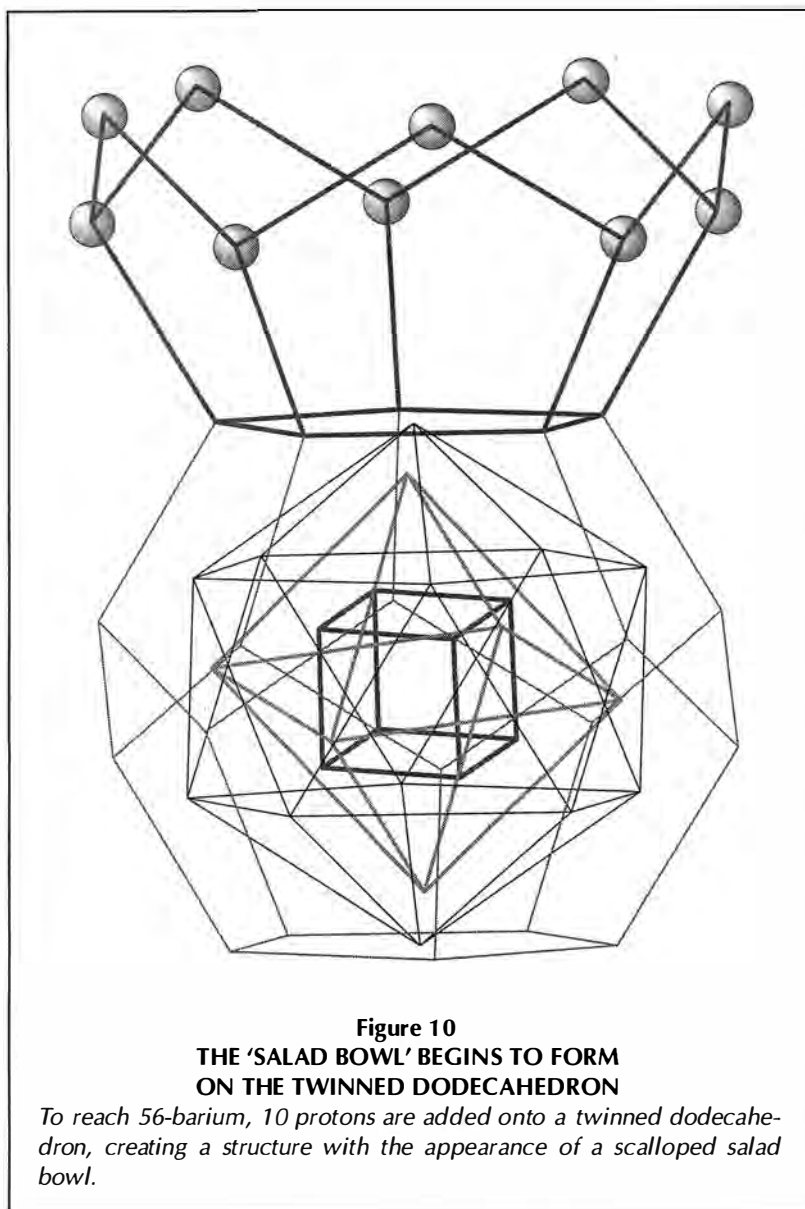
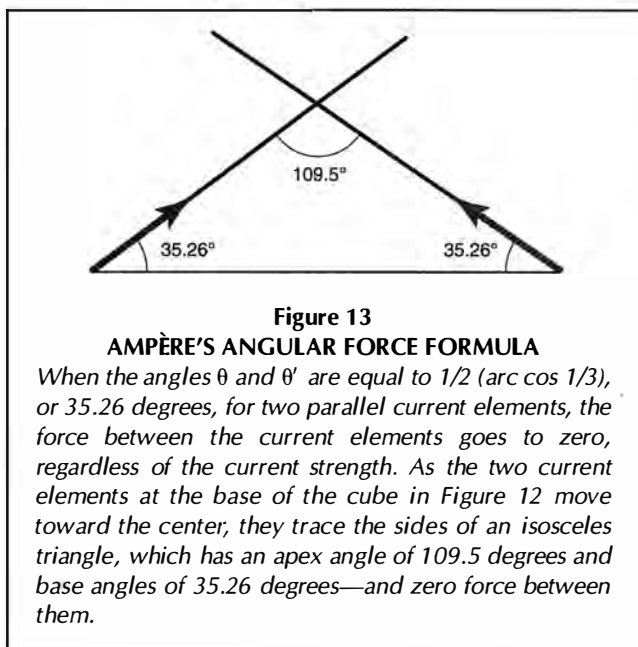
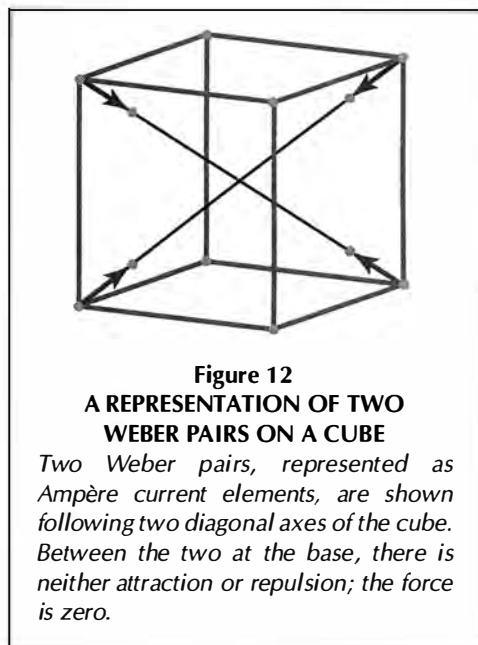
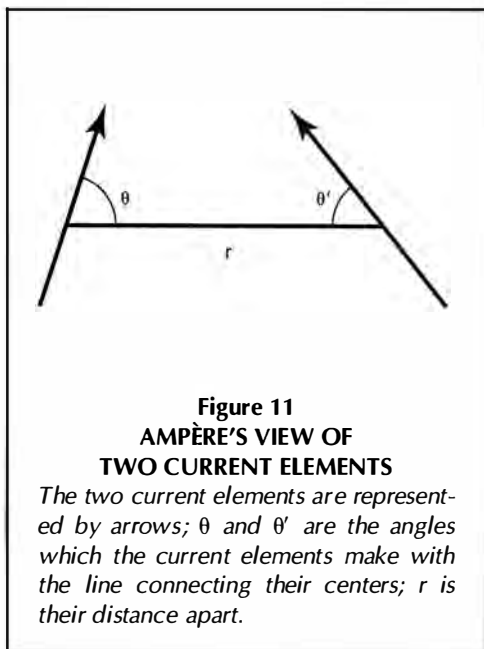

Figure 10
THE 'SALAD BOWL' BEGINS TO FORM
ON THE TWINNED DODECAHEDRON

To reach 56-barium, 10 protons are added onto a twinned dodecahedron, creating a structure with the appearance of a scalloped salad bowl.

law for the force between static charges must be multiplied. The angular term is $[\sin\theta \sin\theta' \cos\omega - 1/2(\cos\theta \cos\theta')]$, where θ and θ' are the angles which the current elements make with the line connecting their centers, and ω is the spatial angle between the current elements.¹³ (See Figure 11.) This means that there will be certain values of θ and θ' for which the force will be zero. Ampère's formal representation embodies the results of one of his earliest electrodynamic experiments, which showed that parallel, current-carrying wires either attract or repel, according as the current is flowing in the same or opposite directions. Clearly, at some intermediate angle, the force between the current elements would reduce to zero, before increasing again.

13. Cf. footnote 3. $F = ii' (ds \cdot ds')/r^2 [\sin\theta \sin\theta' \cos\omega - 1/2 (\cos\theta \cos\theta')]$, where i and i' are the current, ds and ds' the lengths of the current elements, and r their distance apart.



parallel current elements. When the angles θ and θ' are equal to $1/2$ (arc cos $1/3$), or 35.26 degrees, for two parallel current elements, the force between current elements goes to zero, regardless of the current strength. We recognized that the angle was closely connected to the cube and tetrahedron. From the center of the circumscribing sphere, the side of a cube subtends the angle (arc cos $1/3$), or 70.53 degrees. Its supplement of 109.5 degrees, also known to chemists as the tetrahedral angle, subtends the angle between two diagonally opposite vertices on a face. I had tried

many times to make this cohere with the Moon model, always impeded by the fact that I was imagining the current elements to lie at the center of the sphere, where they crossed.

Stevens's proposal to place the current element at the vertices of the solid, (which is to say the surface of the sphere), solved the problem almost instantly, when one recognized that the current coincides with the direction of the Weber pairs; that is, it is moving down the diagonal axes of the Moon model solids. Consider the two Ampère current elements, which are shown at the base of the cube (Figure 12). As they move toward the center, they trace the sides of an isosceles triangle whose apex angle is 109.5 degrees, and whose two base angles are 35.26 degrees (Figure 13). There is thus zero force between them. We must also consider the force between any two of the current elements in Figure 12, which are separated by an edge of the cube. Their angular separation is 70.5 degrees, and a simple calculation shows that they will attract.

However, a curious thing happens when we add the next two Weber pairs, to complete the cube which represents oxygen in the Moon model (Figure 14). We discover that the attractive forces, which all fall along the edges of the cube, resolve in the direction of the cube's diagonal. This is easily seen when we consider a single current element (shown at vertex A) moving toward the center of the completed cube. It will be attracted by the three current elements, which are distant by an edge length. The directions of the attraction are along the three perpendicular directions of the cube's edges. The vector sum of these three motions is the diagonal of the cube, as can be seen by inspection.

Weber pairs arranged along the four axes of a cube, thus produce an electrodynamically stable configuration. From any vertex, the Ampère force along the three adjacent faces reinforces the direction of motion of the charge toward the center. From the same vertex, the Ampère force along the

However, current elements cannot be separated from the circuits which contain them, and there is therefore no empirical means of observing the force between current elements. It may be determined only by creative imagination, by hypothesis. The Ampère angular force formula is one of the more brilliant of those products of the creative imagination, which lie behind all fundamental discovery in physical science.

Stevens and I had been aware for many years of the case referenced in Peter Graneau's book on the Ampère force¹⁴ for

14. Peter Graneau, *Ampère-Neumann Electrodynamics of Metals* (Nonantum, Mass: Hadronic Press, 1985).

face diagonals of the cube is zero. We thus have the curious condition that the motion of current elements along the diagonals of a cube generates a mutual attraction which reinforces the motion! The cube is a self-organizing structure for grouped charges. This suggests a reason

that, from the standpoint of electrodynamics, the cube will be the first stable configuration of the Moon model.

We have still to examine these relationships more closely. The octahedron, which forms next, must be examined in the totality of its relationship to itself, and to the cube, and so forth.

Gadolinium

The case of gadolinium, the lanthanide with a magnetic susceptibility approaching that of iron, gave us a preliminary insight into the stability of the dodecahedron. Upon Stevens's insistence that the "salad bowl" must be formed at 56-barium, I abandoned my overcomplicated construction of the lanthanides, and immediately recognized that 64-gadolinium would be the completed cube inside the salad bowl. Shielded by the salad bowl, the cube could spin freely within, while the heavier barium nucleus stood more or less still, providing an arguable basis for the high magnetism. But could the cube spin so? What is the stability of the "salad bowl" structure? On examining this from the same standpoint of Ampère force relationships, it became clear that the geometry of the cube within the dodecahedron was at work. The same relationship of Ampère pairs which causes the stability of the cube is at work in the dodecahedral salad bowl of Figure 15. The salad bowl itself is thus a stable configuration. The cube which forms within it (not the large cube in the diagram, but the smaller one which corresponds to the oxygen cube) must then orient to the diagonal axes of the dodecahedron. These and other complex interrelationships remain to be worked out.

—Laurence Hecht is editor-in-chief and Charles B. Stevens is Associate Editor of 21st Century.

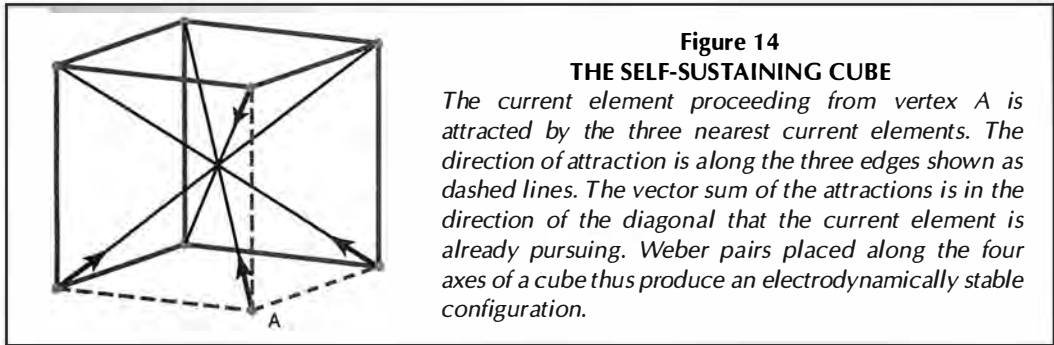

Figure 14

THE SELF-SUSTAINING CUBE

The current element proceeding from vertex A is attracted by the three nearest current elements. The direction of attraction is along the three edges shown as dashed lines. The vector sum of the attractions is in the direction of the diagonal that the current element is already pursuing. Weber pairs placed along the four axes of a cube thus produce an electrodynamically stable configuration.

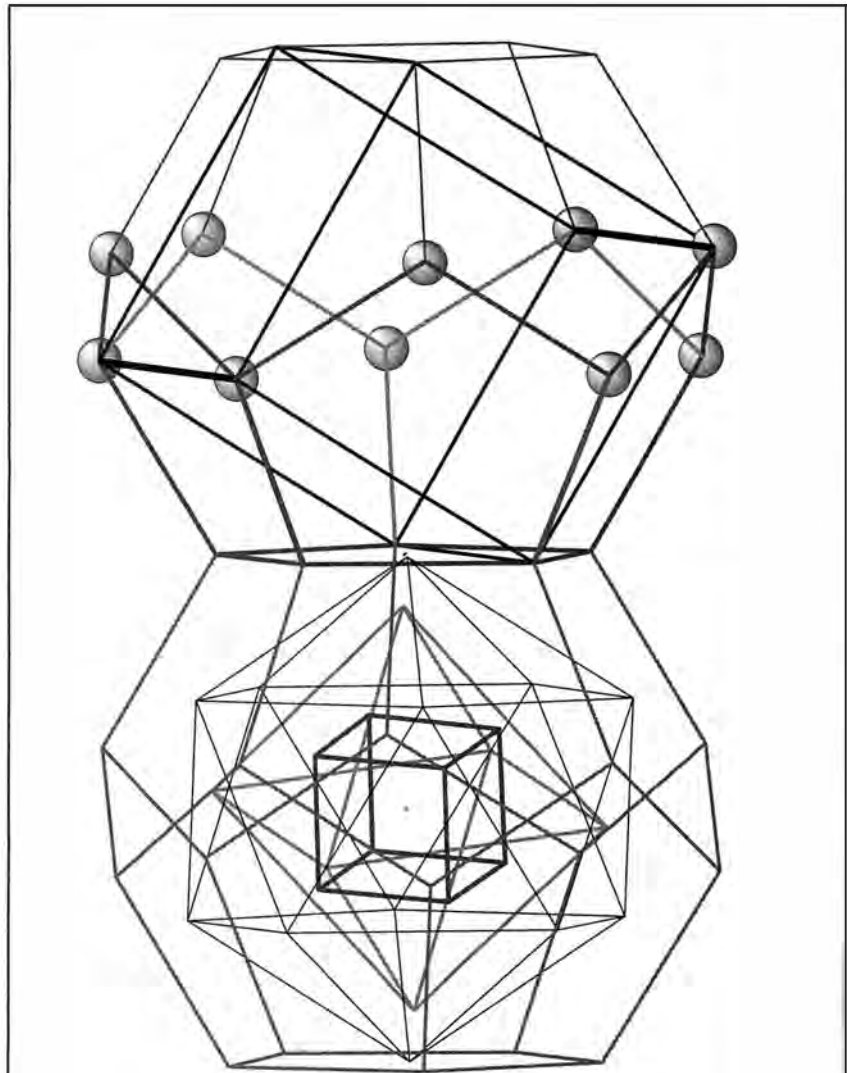

Figure 15

WHY THE 'SALAD BOWL' IS STABLE

The stability of the salad bowl is created by the cube implicit within the dodecahedron. Note the two bold edges of the cube, which also connect pairs of vertices of the salad bowl. Current elements moving along the dodecahedral diagonals between these vertices will experience a zero-force in one direction. The same occurs for other pairs on the salad bowl, creating a stable structure.

Dr. Moon and the Simultaneity of Eternity

by Amie Acheson



Daniel Platt/EIRNS

Amie Acheson: "The opportunity to know a great thinker's mind does not die with the person."

When I first met Dr. Moon, I was about 10 years old. It was at the LaRouche summer camp, and I had no idea I was in the presence of genius. The one thing I do remember is how loving a person he seemed to be. It was before his wife, Christine, passed away from Parkinson's Disease. He would push his wife around in her wheel chair, and you could see how much he cared for her. You could also see the passion with which he talked about science and ideas. Even though I don't remember all the experiments we investigated, I remember the spark of excitement in his eyes.

It was about five years later when I met Dr. Moon again. This time he was giving my mother away at her wedding. Again, I

took for granted the fact that I had access to such an amazing mind. If I knew then what I know now, I would have cornered him at the reception and asked him a million questions. Unfortunately, he passed away before this opportunity occurred.

However, the opportunity to know a great thinker's mind does not die with the person, and so it was years later, as a member of the LaRouche Youth Movement, that I again encountered the beauty of Dr. Moon's mind. It was when Larry Hecht had come out to Los Angeles, and gave a class on the Moon model of the nucleus. As Larry explained the beauty, symmetry, and potency of the Moon model, and I saw its coherence to the Platonic solids and the work of Johannes Kepler, I kicked myself a thousand times for not having had that discussion with Dr. Moon when I had the chance. I got really excited at all the implications that the Moon model had for explaining atomic science and the order of the universe, although it was not until a few years later that I would follow up and do some work on it myself.

From Kepler's Symmetry to Moon

It was at the July 16-18, 2004, West Coast cadre school of the LaRouche Youth Movement (LYM), that I and several other LYM members decided to do a presentation of these ideas. The presentation began with Jason Ross discussing the question of curvature. He went through some of the ideas from Kepler's paper "The Six-Cornered Snowflake," where his investigation of the six-fold symmetry of the snowflake led Kepler not to snow or ice, but instead to the shape of beehives and pomegranates. These investigations led him to discover the reason for the six-cornered shape of honey bee cells and pomegranate seeds. Kepler's approach was that "the cause was not to be looked for in the material, but in an agent." For Kepler, the agent was God's ordering of the universe in the most perfect way.

Jason used the packing of Styrofoam balls and Play-dough to demonstrate ordering principles inherent in space.

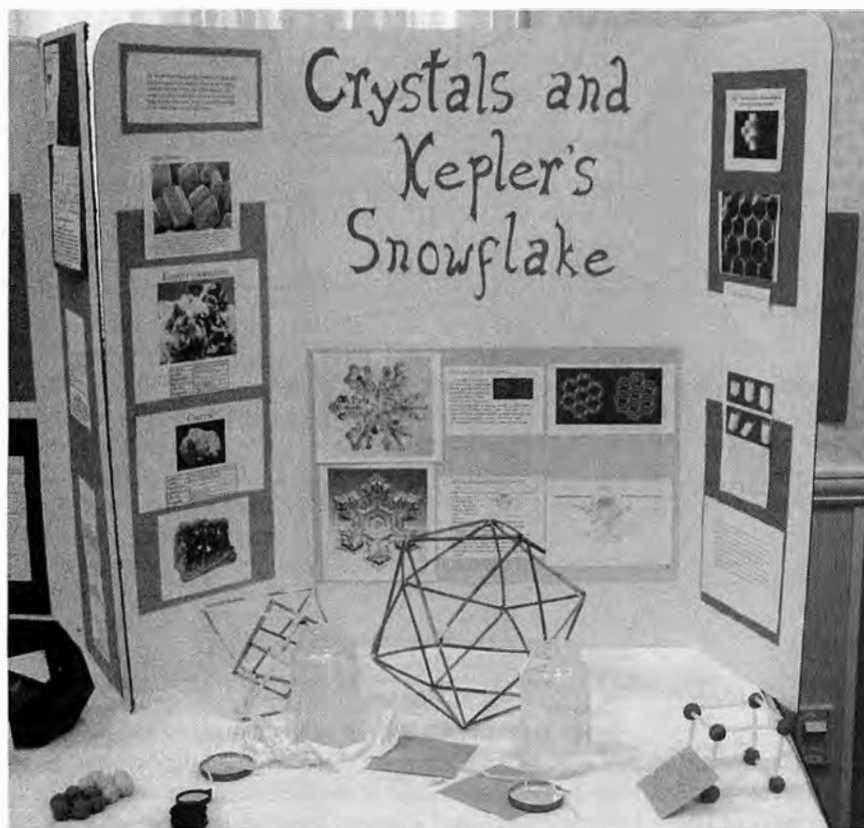

Gene Schenk/EIRNS

A pedagogical display on Crystals and Kepler's Snowflake. Jason Ross noted in his presentation that Kepler's investigation of a cause in the small by its action in the large, set the stage for atomic studies.

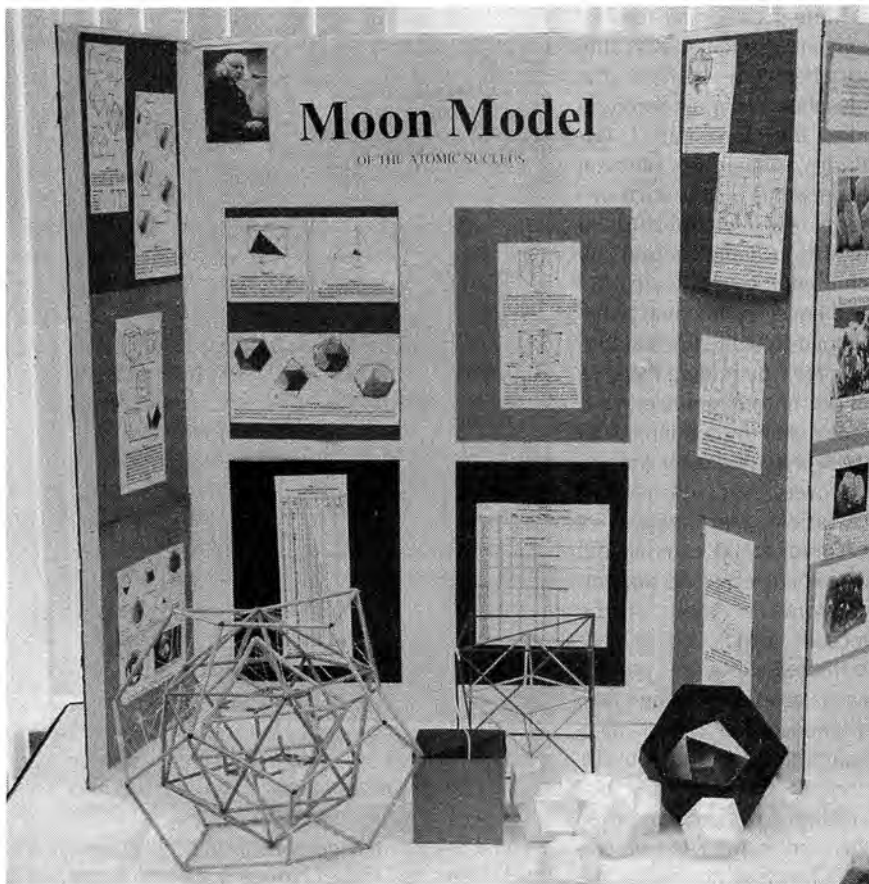

Gene Schenk/EIRNS

This display, the Moon Model of the atomic nucleus, explores Kepler's view of the Platonic solids as an ordering principle.

Kepler took this approach of the fitness of form, to the snowflake. In contrast to the honeycomb and the pomegranate, where the shape of each cell and seed was determined by their being a part of a whole, Kepler noted: "No purpose can be observed in the shape of a snowflake; the six-cornered shape does not bring it about, that the snowflake lasts or that a definite natural body assumes a precise and durable shape. My reply is, formative reason does not act only for a purpose, but also to adorn."

Kepler ends his investigation with the beauty of six-sidedness itself, taking up botany, metallurgy, and crystallography. Kepler's investigation of a cause in the small by its action in the large set the stage for atomic studies.

Cusa's Proportional Relationships

Next, Danny Bayer led a discussion of Nicholas of Cusa's *Idiota de Staticis* (The Layman on Weights). Danny explained how the roots of modern science could be found in this 15th Century work,

where Cusa shows how by investigating proportional relationships, one can figure out how to see with your mind what you cannot see through your senses—proportional relationships such as those you could find using a balance. For example, you could weigh a volume of the urine of a healthy man against an unhealthy, and by finding the average differences in densities, this method can be used as a diagnostic tool for medicine. It was precisely by investigating these types of proportionalities that Antoine Lavoisier and Dmitri Mendeleev (350 to 400 years later!) were able to "see" elements and relationships that no one else could see.

As another example of this, Jason Ross carried out an electrolysis experiment. He tried to demonstrate the law of simple proportions by attempting to split water into hydrogen and oxygen gas. It was looking at these relationships in the visible domain that gave insight into what was happening in the non-visible domain.

From the Visible to the Unseen

At this point, Ed Park and I briefly discussed and carried out some of the experiments of André-Marie Ampère, Carl Friedrich Gauss, and Wilhelm Weber, who were also trying to use the visible to explain the unseen principles of the non-visible, in this case in the realm of electromagnetism. We built Ampère's solenoid experiment, in which he showed that coiling conducting wire around a cylinder, and running an electric current through it, could produce a magnetic effect in the material. Ampère hypothesized that magnetism comes from the motion of resistance-less electrical currents in tiny orbits around the molecules of matter; in other words that electricity and magnetism are fundamentally the same thing.

We also discussed Gauss's crucial political intervention into Weber's thought processes when Weber came under attack by empiricists, such as Hermann Grassmann. Gauss insisted that Weber stick to Ampère's hypothesis of the angular force between electric charges versus the Newtonian's provably false assumptions of force. It was this intervention which led Weber to develop the beginnings of atomic science with his proof and further development of the angular force law, and his discovery of the reversal of the Coulomb barrier below a certain critical length, and of the electron radius.

The Non-'Bohr'ing Moon Model

I then gave a brief biography of Dr. Moon, and went through the Moon model itself. Dr. Moon, through reading LaRouche's writings and Kepler's *Mysterium Cosmographicum*, realized that the same lawfulness that governed the macrocosm of the planetary orbits should also define the order of the microcosm. Looking at Kepler's notion of the Platonic solids as an ordering principle of space, Dr. Moon used the same principle to explain the order of the atomic nucleus. By placing protons on the vertices of the Platonic solids, he was able to account for the stability and abundance of elements such as oxygen, silicon, iron, and palladium which are the filled solids of the cube, octahedron, icosahedron, and dodecahedron respectively.

SCIENCE and
the LaRouche
Youth Movement

SCIENCE and the LaRouche Youth Movement

Moon's physical model is in stark contrast to the "Bohr-ing" model of the electron orbits of Niels Bohr, taught in modern classrooms today. Rather than a flat linear model which explains nothing about a principle, Moon's beautiful and coherent model of the nucleus explains much about the elements and their

behavior that was previously unexplainable; for example, the non-linear change of atomic densities.

Much in the way that Gauss in his 1799 paper on "The Fundamental Theorem of Algebra" defines a surface to help visualize an unseen principle, Moon's model helps us to see a principle in the non-visible domain of the atomic nucleus.

Next, I emphasized the idea that the reason there are so few real discoveries being made in universities or scientific research centers today, is that the method of seeking universal principles has been replaced with a fixation on the empirical world of sense certainty. This was intentionally done by Bertrand Russell and the same Newtonian agents who tried to sabotage the work of Lavoisier, Ampère, Gauss, and Weber. The real scientific breakthroughs will be made by the LaRouche Youth Movement and our collaborators. It is through LaRouche's method and the passion for truth that defines it, that we will find cures for AIDS and cancer, and develop fusion energy, for example. In fact, the only way to develop fusion energy is to get a better understanding of how the atomic nucleus works from the standpoint of Moon's hypotheses.

The Life Principle

Oyang Teng next spoke about how life as a principle subsumes the development of the universe as reflected both in the macrocosm of Kepler's harmonic ordering of the Solar System and in the microcosm of the Moon model of the nucleus. Looking at Vladimir Vernadsky as the successor to Lavoisier and Mendeleyev, Oyang explained Vernadsky's development of the notion of the *biosphere* as determining the structure of how living processes transform the planet, and Vernadsky's further elaboration of how the *noosphere* (the realm of man's creative thought) organizes the biosphere. It

is through our understanding of chemistry that man is able to effectively manage the biosphere through projects like the Eurasian Land-Bridge, which are physical expressions of how we transform our relationship to nature. Oyang ended by challenging those in the audience to become what Vernadsky called a "geologic force," by joining the LYM in our historic political fight.

We are now continuing the work of mastering Dr. Moon's discovery, and are reading Lavoisier's *The Elements of Chemistry*, and carrying out his experiments. We presented some of these at the recently concluded Schiller Institute/LaRouche conference. Jason and Oyang made a pedagogical presentation going through the foundations of chemistry, and discussing how Lavoisier used the work in his *The Elements of Chemistry* to revise the nomenclature of chemistry. In his experiments on decomposing air, Lavoisier discovered two gases. The first one, which was found to improve combustion and support the respiration of animals, had been called *vital air*. Lavoisier renamed it *oxygen* from the Greek for "acid creator," because it had the chemical characteristic of creating acids of substances burned in pure oxygen. The second gas, now called nitrogen in English, was named *azotic gas* from the Greek words meaning "no life," because this gas did not support animal respiration, and killed any animal put into it.

Jason and Oyang also looked into work on spectroscopy, where sunlight is split with a prism or diffraction grating, and it is observed that the rainbow spectrum has gaps in it. These investigations led to the discovery of two new elements, cesium and rubidium, named after the sky-blue and ruby-red emission spectra that the elements made. The developments in spectroscopy not only made it possible to find very minute traces of different elements, but patterns in spectra also gave an idea of the nature of the atom itself. This

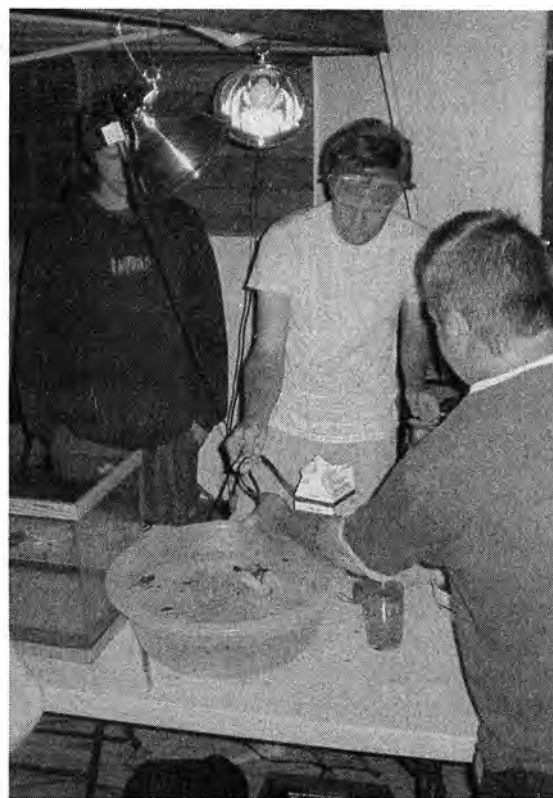

Sylvia Spaniolo/EIRNS

Jason Ross (center) demonstrating the production of hydrogen gas, by running a current through a container of epsom salts and water. The water turns green.

helped lead into Mendeleyev's periodic table of elements.

Lastly, Jason and Oyang presented the discovery made at the Ecole Polytechnique by Joseph Louis Gay-Lussac on the law of simple proportions, which was taken up and developed by Amadeo Avogadro, and also by Ampère. The idea was that all gas reactions occur according to simple ratios (such as one part of one gas combining with exactly two parts of another). Avogadro hypothesized that the same volume of any gas will have the same number of particles composing it.

This hypothesis led into a major debate at the 1860 Karlsruhe International Congress of Chemists, with Cannizzaro defending the Ampère-Avogadro hypothesis. Cannizzaro, who won the debate, insisted that molecules were the smallest elements of substance taking part in reaction, and atoms the smallest part into which molecules can be divided. At the conference, he was able to establish a standard to be used for measuring the atomic weights of the

various elements, a necessity for Mendeleev's later work in systematizing the periodic table.

Nuclear Women

Liona Fan-Chiang gave a pedagogical presentation discussing the women who developed atomic science, such as Marie Curie, Lise Meitner, and Ida Noddack. It is truly amazing that it was primarily women who developed atomic science, and yet many of them got no recognition for their work and had to struggle through many obstacles, including gender discrimination and Anti-semitism to be able to do their work. It was Marie Curie who first discovered radioactivity and Maria Goeppert-Mayer who worked out the shell structure of the nucleus and made contributions to isotope separation and laser physics. Lise Meitner initiated and directed a series of investigations which led to the 1939 demonstration of fission, five years after fission had been conjectured by Ida Noddack.

In another presentation, I further developed some of the ideas from Kepler's snowflake paper, looking into the question of the order of living and non-living substances. Kepler's observations that living substances demonstrate five-fold symmetry, such as many flowers and most fruits, and that non-living display six-fold symmetry, such as crystals and snowflakes, gave an interesting insight into the question of what is life.

I grew some salt and sugar crystals to show the six-fold symmetry in the crystals—the salt crystals forming cubes, and the sugar crystals forming hexagonal growth. This also showed a continuity with the Moon Model of the nucleus, having the visible domain again reflecting the relationships of the Platonic solids hypothesized in the non-visible.

Rediscovering the Method of Discovery

Overall, the main idea we want to communicate is that we, as the LYM, are leading people to rediscover the method by which fundamental discoveries are made in science, as well as in music and economics, and that it is through LaRouche's method that we will make the necessary discoveries to transform the universe out of a Dark Age and into a Renaissance.

We encourage all revolutionary thinkers to join the fun and help us continue Dr. Moon's great legacy!

BOOKS

The Mind Vehement for Truth

by David Cherry

**Richard Nelson Thomas—
NonEquilibrium Thermodynamical
Astrophysicist**

Nora Andreasian, Editor
Hardcover, 160 pp.

Published by the editor, 2003, and available gratis from her: nthomas@uvi.edu or P.O. Box 304923, St. Thomas, VI 00803, USA

"His every act was guided, consciously or unconsciously, by his firm conviction that the ultimate purpose of intelligent life on Earth is the pursuit of scientific truth. . . . The stars must have felt his impact." That is the verdict of John Evans, first director of the National Solar Observatory, on the groundbreaking astrophysicist, Richard Nelson Thomas (1921-1996), in this memorial album. The 28 contributors—and the editor, Thomas's collaborator—provide a composite sketch of his scientific biography. He scoffed at the idea of writing his own biography, saying that people who wrote about themselves had nothing better to do.

The contributors say that he "was one of the deepest thinkers in astronomy in this [20th] century," "one of the very few astrophysicists who really marked the second half of this century with their strong personality and their leading ideas," had a "consuming desire to find out how stars work," was "an angry dear friend," who "did nothing the way anyone else in the world did," and "was one of the most transparently honest people I have ever known," with great "depth of humanity," "unfailing kindness," and "generosity."

From my own friendship with him in the last years of his life, I can say that the portrait is faithful to its subject.

Although he was in the academic world, he was not of it. He regarded the *Brotgelehrte*—careerists—as "boring, stupid, and unfortunate." "Me, I die if can't follow my curious nose," he wrote, and so, "one will do research . . . independently of whether support comes or not." He was oblivious to peer opinion: "Do you need a 'conforming peer vote' before believing your own results?" Thomas's

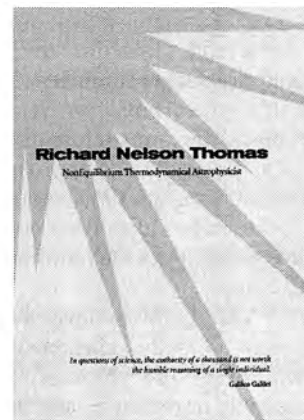

1992 document from which these quotes come, is included in the book.

Dick Always Broke the Mold

The invariant in Thomas's approach to astrophysics was to break the mold: to doubt the prevailing doctrines on the behavior of the Sun and stars (and the accepted methods for analyzing them), use his reason to form an idea of what their behavior should be, and then get data (and develop new methods of analysis) that would test the idea.

Thomas concentrated on solar physics, because the Sun is by far the most accessible of the stars, and he considered it the Rosetta stone for interpreting the others.

The life-long project for which Thomas is best known—indicated in the book's subtitle—arose from a passion to scrap the simplifying assumptions that Sir Arthur Eddington concocted in the 1920s and 1930s to develop his thermodynamic model of "normal" stars. Eddington's assumptions for stellar atmospheres included local thermodynamic equilibrium (LTE), local radiative energy balance, and local hydrostatic equilibrium. But these assumptions were highly artificial even for his "normal" stars, and only have the "merit" of making calculation manageable. Eddington cast aside the so-called "peculiar stars," which posed too many problems for him. This is the familiar trap, of subordinating physics to some

mathematics with a small number of parameters, and sweeping inconvenient phenomena under the rug.

The LTE approach supposed that, at any given depth in the star's atmosphere, radiation and matter were in equilibrium and at one temperature, and that the one temperature could be used to identify the state of excitation and ionization of all atoms, ions, and molecules there (the Boltzmann distribution of energy states). The physical state at any given depth was defined simply by temperature and density! Not surprisingly, this approach led to contradictory results: One could fit the results for hydrogen ions to an observed spectrum, or those for helium ions, but not both at once.

Thomas could not believe that the atmospheres (initially, chromospheres) could obey LTE. The chromosphere is energized only from below, after all. For the solar chromosphere, the kinetic temperature of electrons is about 5,600 K and the black body radiation temperature is about 3,000 K. How could one speak of equilibrium or a single temperature? To discover the actual condition of chromospheres, it would be neces-

sary to compute the probabilities of transitions for every energy state of every ionization stage of each atomic species.

Thomas set his students to work making calculations of transition probabilities. And he pushed hard for an expedition to Khartoum, to obtain high-resolution spectra from the 1952 solar eclipse to test his idea. When the calculations were compared with the Khartoum observations, the first solid evidence of the validity of non-LTE emerged. One did not have to choose between hydrogen and helium!

From this work emerged *Physics of the Solar Chromosphere* by Thomas and his student, Grant Athay (1961). The book won some converts. In the Soviet Union, the book was translated and widely used. But the dominant reaction was tremendous resistance, and Albrecht Unsöld at Kiel University attacked the Non-LTE results and attempted to explain them away. There is still some resistance today, but Non-LTE is well established.

Laboratory Astrophysics

Thomas did not wait for the book to appear to plan the next step. In 1958, he and Lewis Branscomb, head of the Atomic Physics Division of the National Bureau of Standards labs in Washington, developed the concept of "laboratory astrophysics" (some laughed at the apparent oxymoron). The laboratory would be used to study atomic energy levels, radiative transfer in non-equilibrium hot gases, and plasma physics, just what the Non-LTE approach required. In 1962, they succeeded in establishing the Joint Institute for Laboratory Astrophysics in Boulder, Colorado, with the participation of the National Bureau of Standards and the University of Colorado, and with funding from the Pentagon's Advanced Research Projects Agency.

Thomas was no friend of the computer as an aid to astrophysics, because he knew that computer algorithms beguiled their users: They lost touch with the physical processes the algorithms were supposed to represent. But some of his co-workers found that advances in computing made practical some of the difficult calculations for Non-LTE.

The ideas developed by Thomas and his colleagues, with the help of the new ultraviolet observations from spacecraft, overturned the conceptions of stars of all spectral types. Thomas and Stuart Jordan

of NASA persuaded NASA and the Centre National de la Recherche Scientifique in France to sponsor the writing and publication of a series of volumes that would assemble and synthesize the new work on each spectral type—*Nonthermal Phenomena in Stellar Atmospheres*. The 14-year project concluded with the publication of the eighth volume in 1993.

Mass Creation and Mass Outflow

By that time, Thomas had launched an entirely new phase of his work to "redo Eddington"—a phase still so embryonic at the time of his death, that it is scarcely mentioned in this album. He knew that mass outflow from stars (as from stellar winds) must not be treated as a mere function of their energy. Some stars, he said, even seem to lose mass too rapidly to be consistent with their apparent ages. So he thought that Viktor Ambartsumian's ideas about the appearance of new mass in stars (the conversion of superdense "prestellar" matter to the normal state within stars) were a real possibility. The possible creation of new mass was to be a focus of this phase.

He was planning a new international center (Armenia-United States-Mexico) for this work at the time of his stroke in 1992, and worked on the idea fitfully until his death. He told me he wanted Ambartsumian to be the chairman of the board with Halton Arp, Cornelius De Jager, and himself as members.

My conversations with Thomas in the last years of his life went beyond current astrophysics to include the LaRouche movement and Nicolas of Cusa, the 15th Century giant. I brought him William Wertz's book of Cusa translations (*Toward a New Council of Florence*, Schiller Institute, 1993). He could not put it down. He struggled to read it despite visual difficulties from his stroke. Cusa was, I am told, the single most delightful intellectual adjunct to his astrophysical work in his final, bedridden years.

After his stroke, his anguish was great. His mind was active and he tried desperately to continue his work, but could do little. He was a prisoner of his physical condition. He endured a good deal of physical pain. His death was a result of surprising acts of omission and commission by his doctors. But he is alive to us through his work and method, recorded in this memorial album.

**INFINITE ENERGY
MAGAZINE**

New Energy • New Science



Sample Copy of Current Issue
\$5.95 North America/\$10.00 Foreign

Subscription (6 Issues)
\$29.95 North America/\$49.95 Foreign

Contact us for our catalog of books, videos
and other products, or visit our website.

New Energy Foundation, Inc.
P.O. Box 2816-TF
Concord, NH 03302-2816
Phone: 603-228-4516 • Fax: 603-224-5975
<http://www.infinite-energy.com>

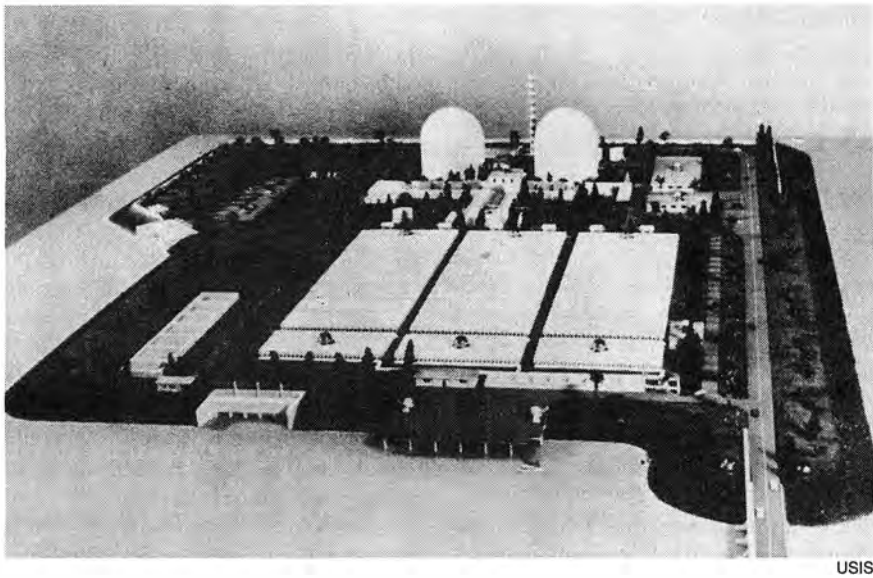

USIS

An artist's conception (circa 1970) of a floating nuclear plant, a man-made nuclear island designed for dual use: supply of electricity and desalinated water for the urban coastal area of southern California. Russia is ready to mass produce them.

U.S. and Russian Labs Call For Nuclear Renaissance

by Marsha Freeman

The heads of seven U.S. energy laboratories, and nine Russian scientific nuclear organizations and institutes met at the Vienna headquarters of the International Atomic Energy Agency July 19-21, and issued a joint document calling for a global expansion of new nuclear energy technologies. The laboratories represented included the three nuclear weapons facilities in the United States and their counterparts in Russia. The meeting was a follow-up to the summit discussions between Presidents George Bush and Vladimir Putin in 2002, which included a call for both sides to look at the future of nuclear power.

"The time has come to develop a comprehensive and realistic plan to ensure the development and deployment of nuclear energy," the joint document states. "It must preserve access to nuclear energy sources for all countries of the world. . . . In addition to providing a virtually limitless supply of secure and reliable energy, a greater use of nuclear energy would greatly reduce the risk of nuclear weapon proliferation and nuclear terror-

ism," as well as improve human health.

This outlook harkens back to President Eisenhower's 1950s Atoms for Peace program, where the widespread civilian use of nuclear energy was seen as a way to uplift developing nations, by giving them access to advanced technologies. The Atoms for Peace outlook has been buried over the past 30 years, under a policy of technological apartheid, which has created a widening gap between industrialized and developing nations. At the same time, anti-nuclear policies have greatly damaged the economies in the now formerly industrialized West.

The participants at the Vienna conference agreed that of all current or imminently developable energy technologies, only nuclear power is capable of meeting the growing world demand for safe, clean, plentiful, and economically viable sources of electricity. The scientists noted that the use of nuclear energy for the production of fresh water, through desalination, and the production of hydrogen, as a limitless and non-polluting fuel, are a critical part of the future deployment of nuclear technology.

The goal stated in the joint document is to have nuclear energy provide 30 to 40 percent of the world's electricity by the year 2050. Today that figure is about 16 percent, produced by 445 nuclear power plants around the world. (See chart, inside back cover.)

We Need 800-1,500 New Plants

In an interview with this author on Aug. 16, Dr. C. Paul Robinson, Director of Sandia National Laboratory, elaborated on the thinking of the group of U.S. and Russian laboratory directors who met in Vienna. Dr. Robinson was chosen by the U.S. laboratory directors as the chairman of the American delegation.

Dr. Robinson explained that energy economists at Sandia Laboratory study projections of world energy growth, but that the perceived limit on the number of plants by 2050, or "where the 30 to 40 percent came from, is based on looking at how feasible it is that you could have that many plants up," and running.

Their estimate is that between 800 and 1,500 units, of 1,000 megawatt-size-equivalent, could be built worldwide in the designated timeframe. Smaller reactors, more suitable for developing nations, would at least double that number of individual reactors.

Since the halt in building new nuclear energy plants starting in the late 1970s, the United States has shut down its capability to manufacture major power plant components. Were a U.S. utility to order a new nuclear plant, it would have to import the pressure vessel!

But Russian institutes have continued to develop new designs and options for nuclear technology. For example, the Russian government has been trying to attract interest and investment in producing small floating nuclear plants, that could be built and deployed quickly.

Floating Nuclear Plants

Dr. Robinson said that the Russians have "presented a lot of material to us,"

on that program. "They've converted a lot of their shipbuilding facilities, that used to build nuclear ships. And they had done far more than the United States, or anybody in the West has done, in terms of nuclear-powered surface ships, icebreaking ships, and submarines.

"When the bottom fell out of the defense industry, they started converting the manufacturing parts to offshore drilling rigs. The Russians have been building a lot of high-value offshore platforms, and believe it's a small step back the other way, to build floating platforms that are power stations."

The floating nuclear power plant concept that the American scientists liked, he explained, "was to tow it to an area where there is a need for power and have a small canal dug from the shore into which you would tow it, and emplace it, so you're isolated from sea states and adverse weather. Then, when you're ready to change out the fuel you tow it back to the central factory."

One initiative by the scientists that is critical to solve the huge deficits in especially, but not exclusively, developing economies, is the provision of new sources of fresh water, and the development of unlimited fuel resources. The two most important "non-electric" uses of nuclear energy, mentioned in the joint document, are the production of hydrogen for fuel, and fresh water, through desalination.

Fresh Water and New Fuel

"Those are both big, big deals," Dr. Robinson said. "We tried to look—both the U.S. and Russian sides—at so-called system solutions, where you look at the total performance of a system. Nuclear plants have always been bothered by the fact that you have to build them considerably larger, in order to meet the peak daytime loads.

"But then at night, you have this very expensive capital resource, without much to do with the power. You try to cut them back as much as you can, but end up having to burn some of the power just into resistors in the evening hours. If you could produce a commodity whose rate of production you could vary day to night—and hydrogen was the first one that we looked at—you can really help the overall sizing issue for nuclear plants, making them more efficient and productive," because the

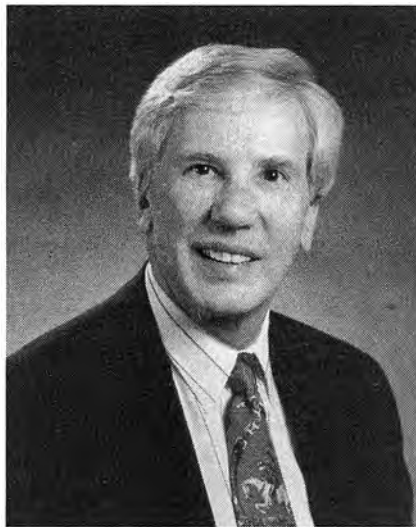

Courtesy of Sandia National Laboratory

Dr. C. Paul Robinson, chairman of the American delegation. Before becoming Sandia's Director in 1995, Dr. Robinson was an advisor to the Defense Department, and headed arms control negotiations with the Soviet Union.

plants could be running at full power, 24 hours a day.

"You would just switch the balance between electrical generation and production of either hydrogen or water," depending upon the demand for electricity.

The idea that the energy produced by a nuclear plant can be used as a centralized heat source and electricity supplier, around which entire new cities, farms, and factories could be built, goes back to the 1960s and 1970s. At that time, there were designs for what were called nuclear-powered agro-industrial complexes, or nuplexes. One of the industrial processes described then was the use of high-temperature nuclear reactors to thermally crack water to produce hydrogen, rather than using the limited supplies of natural gas as a feedstock, which is what is done today.

Dr. Robinson added that another option being looked at is "what you could do with coal or coal slurries. Argonne National Laboratory has done some interesting demonstrations of what you could do with high temperatures" from nuclear reactors, he said.

Although the United States virtually abandoned even written studies of the applications of next-generation nuclear technology over past decades, the

Russians have continued to pursue more advanced nuclear designs.

What was evident, and "amazing," to the U.S. scientists during the discussions with their Russian counterparts, was "how much work they've continued to do in nuclear engineering," Dr. Robinson reported. "They've got the full spectrum of reactors still being evaluated and operating in pilot stage. They've got lead as the coolant, lead bismuth eutectics as coolant material, they've got sodium cooled loops with reactor power operating, and they've got a high-temperature gas reactor operating."

The intention is for each side to contribute in their areas of expertise to the overall effort to resurrect nuclear technology for global deployment. The Russians clearly have the lead in new reactor designs, experimental pilot projects in next-generation technologies, and manufacturing capabilities.

"The United States truly has the edge on anybody in terms of high reliability for manufactured items, or plants. As you know, just within the last decade, nuclear power has finally come into its own, in not only being reliable when it's operating, but bringing up the overall operation times to meet the original expectations. The predictive reliability is the name we give to the technology in the United States that would be so important for the next generation of nuclear plants," Dr. Robinson stated.

"The other area that the United States excels at is control systems. After the troubles at Chernobyl, the Russians realized it would be hard to sell Russian-designed reactors in the international market. But with a U.S.-Russian collaboration, with us bringing the safety and operational controls into being, you get the best of both sides."

In terms of implementation, Dr. Robinson said: "Each side is introducing the document into their government. We've hit several of the Departments here, primarily Energy, and the Russians are doing the same over there. We'll try to move this forward. Both of us are looking at a potential future summit as a next step, on the Presidential level. That's how we got started, as a matter of fact, following the Bush-Putin summit in Moscow, in 2002, [which] had an initiative calling for the two sides to look at the future of nuclear power."

WORLD NUCLEAR POWER REACTORS 2003-2004

Asia is going nuclear, and most of the planned nuclear expansion is in China, Korea, Japan, or India; 21 of the last 30 reactors constructed were in Asia. To fully meet the electricity needs of a growing world economy, would require 6,000 new nuclear reactors by mid-century.

	Nuclear Electricity Generation 2003		Operating Reactors Sept. 2004		Reactors Under Construction Sept. 2004		Reactors Planned Sept. 2004		Reactors Proposed Sept. 2004	
	billion kWh	% e	No.	MWe	No.	MWe	No.	MWe	No.	MWe
Argentina	7.0	8.6	2	935	0	0	1	692	0	0
Armenia	1.8	35	1	376	0	0	0	0	0	0
Belgium	44.6	55	7	5728	0	0	0	0	0	0
Brazil	13.3	3.7	2	1901	0	0	1	1245	0	0
Bulgaria	16.0	38	4	2722	0	0	0	0	1	1000
Canada	70.3	12.5	17	12080	1	515	2	1030	0	0
China*	79.0	**	15	11471	4	4500	6	6000	20	17000
Czech Republic	25.9	31	6	3472	0	0	0	0	2	1900
Egypt	0	0	0	0	0	0	0	0	1	600
Finland	21.8	27	4	2656	0	0	1	1600	0	0
France	420.7	78	59	63473	0	0	0	0	0	0
Germany	157.4	28	18	20643	0	0	0	0	0	0
Hungary	11.0	33	4	1755	0	0	0	0	0	0
India	16.4	3.3	14	2493	9	4128	0	0	24	13160
Indonesia	0	0	0	0	0	0	0	0	2	2000
Iran	0	0	0	0	1	950	1	950	3	2850
Israel	0	0	0	0	0	0	0	0	1	1200
Japan	230.8	25	54	45521	3	3294	12	14436	0	0
Korea DPR (North)	0	0	0	0	1	950	1	950	0	0
Korea RO (South)	123.3	40	19	15880	1	960	8	9200	0	0
Lithuania	14.3	80	2	2370	0	0	0	0	0	0
Mexico	10.5	5.2	2	1310	0	0	0	0	0	0
Netherlands	3.8	4.5	1	452	0	0	0	0	0	0
Pakistan	1.8	2.4	2	425	0	0	1	300	0	0
Romania	4.5	9.3	1	655	1	655	0	0	3	1995
Russia	138.4	17	30	20793	5	4550	1	925	8	9375
Slovakia	17.9	57	6	2472	0	0	0	0	2	840
Slovenia	5.0	40	1	676	0	0	0	0	0	0
South Africa	12.7	6.1	2	1842	0	0	0	0	1	125
Spain	59.4	24	9	7584	0	0	0	0	0	0
Sweden	65.5	50	11	9459	0	0	0	0	0	0
Switzerland	25.9	40	5	3220	0	0	0	0	0	0
Ukraine	76.7	46	14	12218	2	1900	0	0	0	0
United Kingdom	85.3	24	23	11852	0	0	0	0	0	0
USA	763.7	19.9	103	97497	1	1065	0	0	0	0
Vietnam	0	0	0	0	0	0	0	0	2	2000
WORLD	2525	16	438	363,931	28	22,517	35	37,328	71	55,000

Sources: For reactor data, World Nuclear Association; for nuclear electricity production and percentage of electricity (%e), International Atomic Energy Agency. kWh = kilowatt-hour, MWe = megawatt, electric.

* China: The operating capacity for China includes 9 reactors on the mainland (6587 MWe) generating 41.6 billion kWh, and 6 on Taiwan (4884 MWe) generating 37.4 billion kWh—2.2% and 22% of total respectively. Reactors under construction include 2 on the mainland (1900 MWe) and 2 on Taiwan (2600 MWe). Ten reactors are on order on the mainland (6,000 MWe).

In This Issue

NEW EXPLORATIONS WITH THE MOON MODEL

New work on the geometric nuclear model developed in 1986 by Dr. Robert J. Moon shows a unique spin axis for the nucleus, suggesting the explanation for many previously unexplained nuclear properties. The recent investigation by Laurence Hecht and Charles B. Stevens, appearing in our feature section, also suggests the reason for the electrodynamic stability of the nucleus.

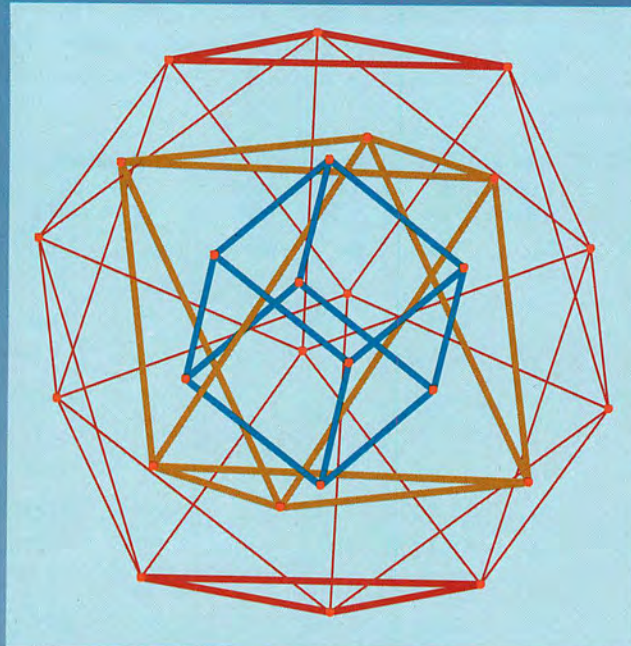

Jacob Welsh

◀ The faces of the icosahedron that are parallel to the octahedron in the Moon nuclear model are shown at top and bottom, emphasized by thick lines.

Stable configurations of paired protons ("Weber pairs") are shown, aligned along three axes of the cube. Analysis of the Ampère force between and among these current elements shows the cube to be electrodynamically self-stabilizing. ▼

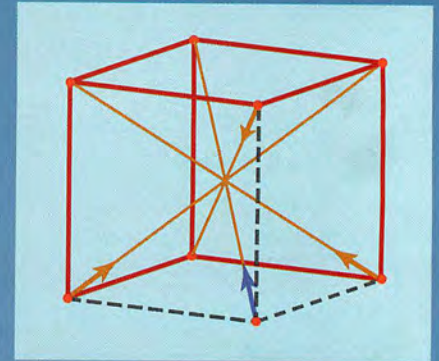

IT'S TIME FOR A NUCLEAR RENAISSANCE!

U.S. national energy laboratories and Russian nuclear institutes released a joint statement calling for a nuclear renaissance. Marsha Freeman reports on their meeting, and interviews the director of Sandia Labs on the proposed plans to build 800 to 1,500 nuclear plants by 2050.



Photographs © AREVA/Liesse

China plans to build 30 more nuclear reactors by 2020. Above: China's Ling Ao 1 and 2 nuclear plants in Guangdong Province. Both 1,000-MW pressurized water reactors were supplied by AREVA, and commissioned in 2002. At left: fuel loading at Ling Ao 1.